

Implementation of Soft Starter Using 3 Phase Induction Motor

¹Saurabh B.Ganar, ²Omkar V. Jodh, ³Prof. Gaurav G. Gulhane

^{1,2}Student of Final Year, Electrical (Electronics & Power) Engineering, Department Babasaheb Naik College of Engineering, Pusad

³Assistant Professor, Electrical (Electronics & Power) Engineering, Department Babasaheb Naik College of Engineering, Pusad

Abstract: This paper describes the soft and smooth start to a 3 phase induction motor. The three phase induction motor during the initial starting condition draws up much higher current than its capacity and the motor instantly reaches the full speed. This results in a mechanical jerk and high electrical stress on the windings of the motor. Sometimes the windings may get burnt. The prototype has been developed to give a soft start to the induction motor based on the SCR firing triggered by heavily delayed firing angle during starting and then gradually reducing the delay till it reaches zero voltage triggering. This results in low voltage during start and then gradually to full voltage. Thus the motor starts slowly and then slowly picks up to full speed. The working prototype consists of a six anti-parallel SCRs, two for each phase, the output of which is connected to a set of lamps representing the coils of a 3 phase induction motor, capacitors, comparators, opto-isolators to trigger the SCRs etc. This can be enhanced by using IGBTs in place of SCRs with PWM control to reduce harmonic distortions often encountered in SCR triggering mechanism for future scope. The implementation of hardware model has been discussed in this paper.

Keywords: SCR triggering; Firing angle delay; optoisolators; optocouplers; zero voltage triggering ; motor current control

1. Introduction

The project is designed to provide a soft and smooth start to a 3 phase induction motor. The three phase induction motor during the initial starting condition draws up much higher current than its capacity and the motor instantly reaches the full speed. This results in a mechanical jerk and high electrical stress on the windings of the motor. Sometimes the windings may get burnt. The induction motor should start smoothly and gradually catch up the speed for a safer operation. This project is designed to give a soft start to the induction motor based on the SCR firing triggered by heavily delayed firing angle during starting and then gradually reducing the delay till it reaches zero voltage triggering. This results in low voltage during start and then gradually to full voltage. Thus the motor starts slowly and then slowly picks up to full speed [1]. This project consists of a six anti-parallel SCRs, two for each phase, the output of which is connected to a set of lamps representing the coils of a 3 phase induction motor. The charging and discharging of capacitors is interfaced to comparators resulting in delayed firing pulses during start and then gradually reducing the delay till the motor runs at full speed. Output from the comparators is fed through opto-isolators to trigger the SCRs. Further the project can be enhanced by using IGBTs in place of SCRs with PWM control to reduce harmonic distortions often encountered in SCR triggering mechanism.

2. Description

A. Soft Starters

A soft starter is another form of reduced voltage starter for A.C. induction motors. The soft starter is similar to a primary resistance or primary reactance starter in that it is in series with the supply to the motor [2]. The current into

the starter equals the current out. The soft starter employs solid state devices to control the current flow and therefore the voltage applied to the motor. In theory, soft starters can be connected in series with the line voltage applied to the motor, or can be connected inside the delta loop of a delta connected motor, controlling the voltage applied to each winding.

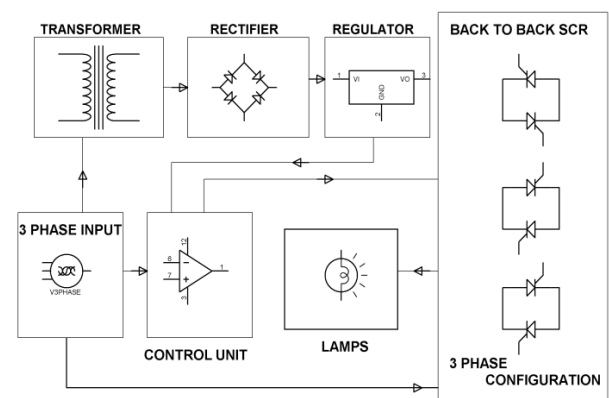

Figure 1: Block diagram for soft starting of induction motor

There is the block diagram shown in the fig 1 in this voltage is controlled by SCRs [3].

B. Voltage Control

Voltage control is achieved by means of solid state A.C. switches in series with one or more phases. These switches comprise either as shown in fig 2. These Solid State Switches are phase controlled in a similar manner to a light dimmer, in that they are turned on for a part of each cycle. The average voltage is controlled by varying the conduction angle of the switches.[4] Increasing the

conduction angle will increase the average output voltage. Controlling the average output voltage by means of solid state switches has a number of advantages, one of the major advantages being the vast improvement in efficiency relative to the primary resistance starter, due to the low on state voltage of the solid state switches.

1 x Triac per phase

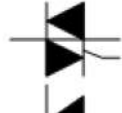

1 x SCR and 1 x Diode reverse parallel connected per phase.

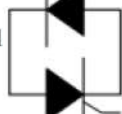

2 x SCRs reverse parallel connected per phase.

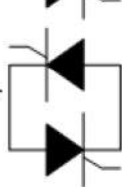

Figure 2: Solid state switches

Typically, the power dissipation in the starter, during start, will be less than 1% of the power dissipated in a primary resistance starter during start [5]. Another major advantage of the solid state starter is that the average voltage can be easily altered to suit the required starting conditions. By variation of the conduction angle, the output voltage can be increased or reduced, and this can be achieved automatically by the control electronics [6].

3. Circuit Diagram of Proposed Model

The 3 phase induction motor should not be given full voltage at a time of starting, because in off condition the back EMF of the motor is very low, So initially it draws high current. To start the motor with low current, two SCR'S are connected back to back in each phase and are triggered slowly initially by delayed firing angle and gradually the triggering pulse is increased by decreasing the delay in firing angle till zero delay so that motor current slowly rises without any excessive current during the starting of the motor. To trigger the gates of SCRS, the operational amplifiers are used i.e. LM339 and LM324. Lm324 op-amp is configured to get a level voltage comparison at its input that will initially be high and gradually full to zero. as shown in fig 3. To achieve the above operations +12v DC supply is required. So we generate our own DC power supply as follows.

Three step-down transformers are used to step down 230v AC to 12v AC for each phase; three bridge rectifiers are connected to convert 12v AC to DC. Since we need pure DC as well as pulsating DC, a blocking diode is employed after each bridge rectifier to isolate pulsating DC and pure DC. After blocking a filter capacitor is connected to get the pure DC. The AC supply is not constant always so a 7812 voltage regulator is employed to get the fixed 12v DC supply. A 10uf capacitor is connected at the output of 7812 for stability; a LED with a series resistor 1k is connected to indicate the power. Lets discuss about the

ramp generation and level generation for one phase and the same thing is applied for rest 2 phases.

For generating level voltage a p-n-p BC 558 transistor is used whose emitter is connected to the +12v supply and base is connected to a ceramic capacitor 0.4uf and the collector is connected to an electrolytic capacitor 2.2uf via 10k resistor as shown in fig 4.

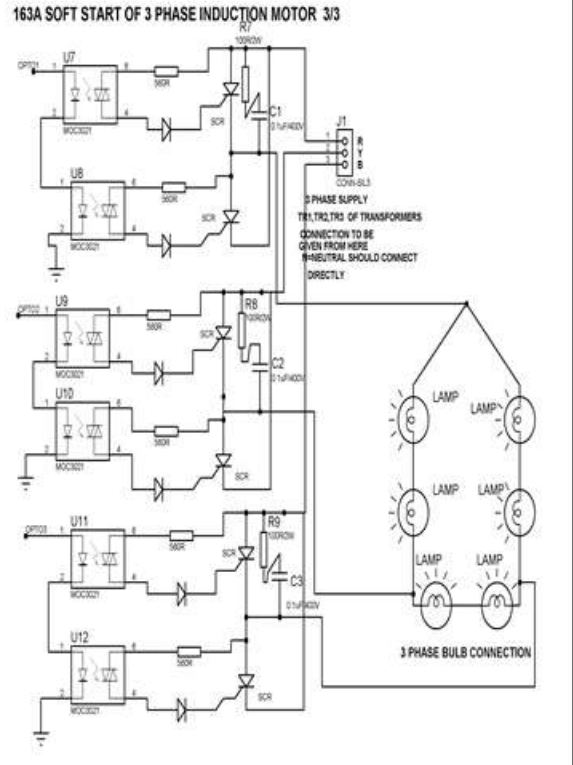

Figure 3: Circuit diagram of proposed model

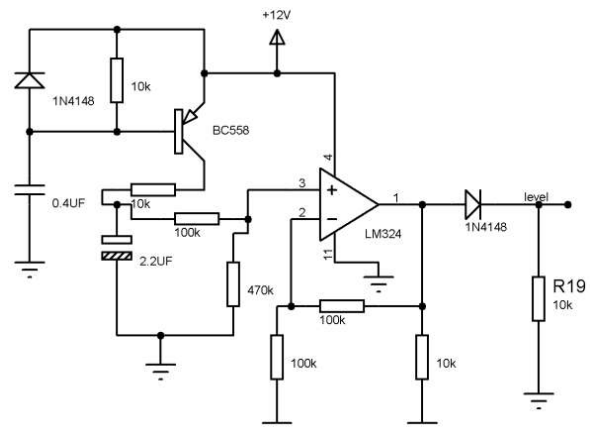

Figure 4: Showing voltage level in p-n-p BC 558

Initially at the time of switch on the base of transistor allows current flow from emitter to base and charges the 0.4uf capacitor as well as current flows from emitter to collector and charges 2.2uf capacitor. When 0.4uf is fully charged, the base becomes high due to which the current stops flowing from emitter to base and collector. The positive terminal of 2.2uf capacitor is connected to the non-inverting pin of LM324 comparator, the inverting

terminal of comparator is fed from a fixed voltage. When the 2.2uf capacitor is charging the voltage at non-inverting terminal is greater than the inverting terminal, hence the output of comparator is high during this time. When the 2.2uf capacitor starts discharging the voltage at the output of comparator also falls gradually because the voltage at non inverting terminal falls lower slowly than the inverting terminal. Hence the level of the voltage is initially high and gradually falls down; this level voltage L is fed to another comparator of Op-amp LM339.

4. Hardware Implementation

The circuit diagram has been implemented using the following components and the prototype has been tested for bulb load. The details of which is provided in table 1.

Table 1: Details of components used in hardware

Component Name with rating	Quantity
Resistors	
560R	6
1K	7
2.2K	3
3.3K	3
4.7K	9
10K	6
22K	6
27K	1
100K	3
2.2M	2
100R/2W	3
Capacitors	
470uF/35V	1
10uF/63V	1
2.2uF/25V	4
0.47uF (470nF) Polyester	2
0.1uF/400V Polyester	3
Diodes	
1N4007	21
IN4148	5
Integrated circuits	
7812	1
LM339	2
LM324	1
MOC3021	6
IC Base	
14-Pin Base	3
06-Pin Base	6
Transistors	
BC558/BC557	4
BC547	3
Miscellaneous	
Push Button 2-Pin	1
Transformer 0-12V, 500Ma	3
LED-Red	2
LED-Yellow	1
LED-Green	1
Male Burge 2-Pin	3
Female Burge 2-Pin (For Transformers)	3
Heat Sink	7
Screw Nut for Heat	7
SCR (TYN612 OR TYN616)	6
PCB Connectors 3-Pin	2
Lamp	6

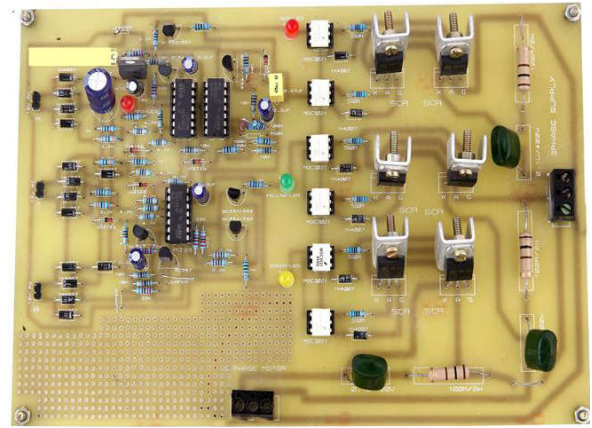

Figure 5: The circuit involved in prototype

The prototype has been developed as shown in the model in fig 5 and fig 6. The same has been tested for load resembles the induction motor.

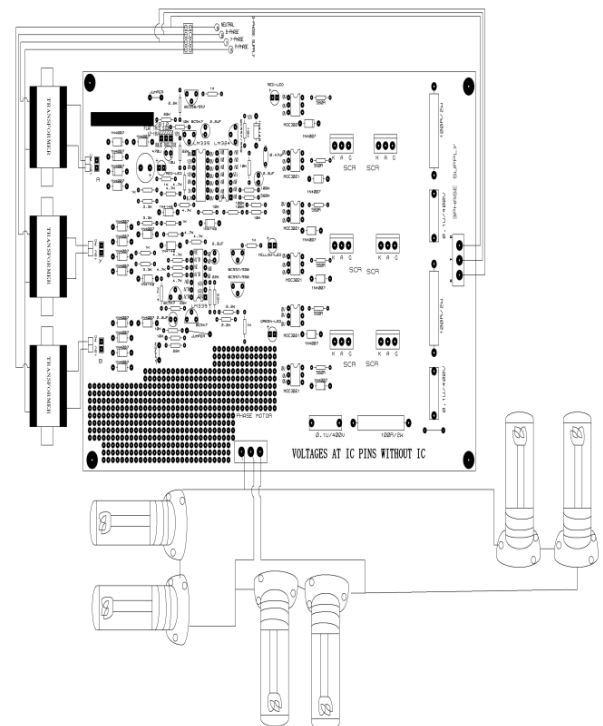

Figure 6: The complete prototype and its circuit

The expected outcome in the form of wave form has been shown in fig 7. These are the waveforms which could be seen in CRO. It shows the power variations, voltage variations and current variations in the prototype showing the soft starting of the induction motor.

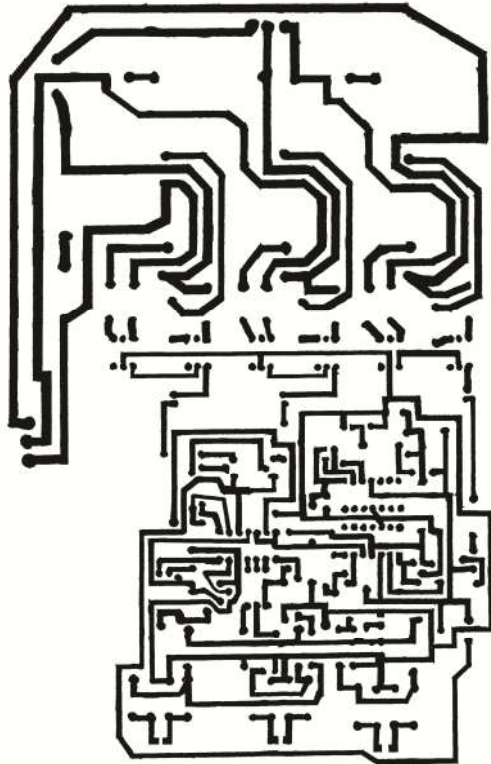

Figure 7: PCB Layout

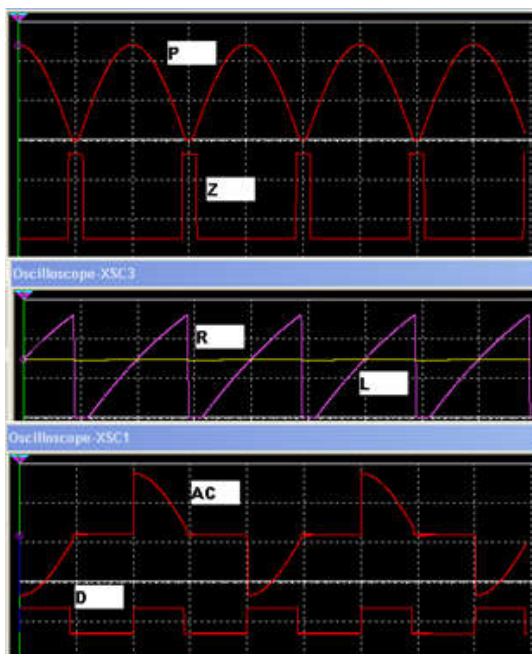

Figure 7: Expected outcome

Advantages

- Eliminates high inrush current and high mechanical torque on startup.
- Reduction in cable and switch-gear rating in the power supply network.
- Limits line voltage dip.
- Soft, stepless acceleration & deceleration.
- Kick-start function for heavy duty and functional loads with high starting torque.
- Current limiting characteristic.
- By-pass contactor increases energy savings.
- Avoid current and torque peaks, Put less electrical stress on the power supply network and mechanical stress on entire drive.
- Reduce stress on couplings and other transmission devices (gear boxes, shafts, belts, etc).

Disadvantages

- Produces harmonics(less than inverter)
- Operating speed of motor fixed(unlike VFD, frequency is fixed)
- Speed regulation is not possible(used for only starting & stopping and protection)
- Acceleration & deceleration time more depend on load.

Conclusion

Realization of this prototype will enhance the safety of induction motor and solve the problem related with its starting .Use of this technology makes induction motor more cost effective and efficient. So it can be implemented for small scale industries also. Further enhancement can be done by the use of IGBT which will reduce the harmonics and make it more effective for industries.

References

- [1] G. Bhuvanewari, Charles. S and Manjula G. Nair. "Power Quality Studies on a Soft Start for an Induction Motor". 2008 IEEE.
- [2] Ahmed Riyaz, Atif Iqbal, Shaikh Moinoddin, SK. Moin Ahmed and Haitham Abu-Rub "Comparative Performance Analysis of Thyristor and IGBT based induction motor soft starters". International journal of engineering, Science and Technology Vol.1, No.1, 2009, pp. 90-105.A. M.
- [3] Eltamaly, A.I. Alolah and R. M. Hamouda "Performance Evaluation of Three Phase Induction Motor under Different AC Voltage Control Strategies". 2007 IEEE.
- [4] Cui Naxnin, Zhang Qingfan," The application of the fuzzy control technology in intelligent soft start", PhD Thesis, Shandong University, 2012
- [5] Zhang Zili; Cui Xueshen; Zhao Haisen; Yang Yaping "Research on a novel star -delta soft start method of three-phase induction motor" Power Electronics and Motion Control Conferences (IPEMC), 2012 7th International, Vol.4, pp 2479-2483

- [6] Shihong Gan; Wei Gu; Jianxin Chu; Yuan Yu “Soft starting high voltage induction motors with optimum performance”, Material for Renewable Energy & Environment (ICMREE),2011 International conference, Vol-1, pp 665-659.
- [7] Li Shue, Fu Chao Design and simulation of AC motor soft start. Third International conference on intelligent system and engineering application 2007.
- [8] Gurukan Zenginobuz, Isik Cadirei Soft Starting of Large I M at Constant Current Soft Starting Torque Pulsations IEEE Transactions On Industry Application, vol. 37, no. 5, sept/oct. 2001.
- [9] Obeta, C.N. Mgbachi, C.A. Udeh, I.J. Soft Starter, An Alternative To Motor Control.. ISSN: 2408-7653 Vol. 2