

# A Fully Automated Lawn Cutter Using Solar Panel

Ramya P<sup>1</sup>, Shailendra Kumar<sup>2</sup>, Yogesh Sharma<sup>3</sup>, Hitesh Ritolia<sup>4</sup>, Kondeti Veerendra<sup>5</sup>

<sup>1</sup>Assistant Professor, Department of EEE, Sri Venkateshwara College of Engineering, Bangalore, India

<sup>2,3,4,5</sup>Department of EEE, Sri Venkateshwara College of Engineering, Bangalore, India

**Abstract:** *The solar lawn cutter is a fully automated grass cutting robotic vehicle powered by solar energy that also avoids obstacles and is capable of fully automated grass cutting without the need of any human intervention. The system uses 12V batteries to power the vehicle movement motors as well as the grass cutter motor. We use a solar panel to charge the battery. The grass cutter and Vehicle motors are interfaced to an NodeMCU that controls the working of all the motors. It is also used to interface an ultrasonic sensor for object detection. The SoC moves the bot in the forward direction in case no obstacle is detected. On obstacle detection; the ultrasonic sensor monitors it and the SoC thus stops the grass cutter motor to avoid any damage to the object/human/animal whatever it is. In order to detect the boundaries, the bot uses on a right angle to trigger start event. The detection of the laser on the other side triggers the bot to stop and turn a right angle clockwise and move to next row. The bot takes another right angle turn clockwise and moves forward till the next laser fence is detected. The detection of both the lasers simultaneously triggers the stop event. The L293 bi-motor controller/driver is used.*

**Keywords:** Solar Energy, Solar Panel, NodeMCU (Microcontroller ESP32), Ultrasonic Sensor, SoC (System on Chip), L293 Driver

## 1. Introduction

The first lawn mower was invented by Edwin Budding in 1830 just outside Stroud, in Gloucestershire, England. Budding's mower was designed primarily to cut the grass on sports grounds and extensive gardens, as a superior alternative to the scythe, and was granted a British patent on August 31, 1830. Budding's first machine was 19 inches (480 mm) wide with a frame made of wrought iron. The mower was pushed from behind. Cast iron gear wheels transmitted power from the rear roller to the cutting cylinder, allowing the rear roller to drive the knives on the cutting cylinder; the ratio was 16:1. Another roller placed between the cutting cylinder and the main or land roller could be raised or lowered to alter the height of cut. Without patent, Budding and Ferrabee were shrewd enough to allow other companies to build copies of their mower under license, the most successful of these being Ransomes of Ipswich, which began making mowers as early as 1832.

The lawn mower is an aid in the mundane task of grass cutting and tending to lawns. Due to the revolution of green movement in the present scenario the industries with major campus areas are changing the percentage of greenery in the campuses and increased greenery causes increased effort and money to tend to. In such cases the lawn mower proves to be a good sent. Due to increased availability of system on chips, the lawn mower can be automated very easily and also the reduced size and cost of DC motors causes the system to be independent of fossil fuels to be able to tap into renewable energies. The presence of Ultrasonic sensors in a smaller and cheaper packaging cause the bot to be more aware of its surroundings.

Due to the presence of node MCU in the system causes and increase in the module that can be added. Traditional design of lawn movers had motored powered engines which required regular maintenance such as engine oil and

greasing. They also created a lot of noise pollution and air pollution. In the cold and harsh environment, the fossil fuel powered motors tend to freeze and not run. These problems are solved by using electric motors. They are also much greener because they use solar panel. The mover uses battery chording system causes a range as a limitation and damage to the chords. Our project is a solar powered automatic grass cutter, the purpose is to avoid energy crisis and reduces the human efforts, operating cost and maintenance cost. So it keeps the environment clean.

## 2. Objectives

- The objective of this paper is to design and automatic lawn mower which operates on solar energy and avoids the drawback of old lawn mowers.
- The main objective is to reduce human efforts by using fully automatic lawn cutter.
- The project is powered by solar energy hence the consumption of fossil fuel is reduced.
- The other objective is that the automatic lawn cutter has to differentiate between grass and concrete while monitoring its surroundings continuously.
- The combination of moisture sensor and pump motor is used in order to monitor the soil moisture.
- Vacuum will be used to collect the grass residue.

## 3. Motivation

In the conventional grass cutter, we add so many things new. Now the grass cutter becomes fully automated and there is no any fuel consumption and maintenance part. The grass cutter is totally operated on solar energy, so that the pollution and usage of fuel controlled. The grass cutter becomes automated because of the controlling mechanism i.e. microcontroller. And the obstacles are also detected by the ultrasonic sensor. The speed of vehicle is controlled. The solar grass cutter is used in various applications such as

various types of ground.

#### 4. Methodology

The methodology explain in this paper is similar to the prototype analysis process. In this paper we are fabricating a prototype of the solar powered grass cutter. The methodologies of these attachments are explained in few sub- headings:

- Components of attachment
  - Working of solar grass cutter.
- a) Component of attachment: The main components of the solar powered grass cutter are:
- Software.
  - Hardware
- b) Software used:
- Arduino IDE (6-20V, 40 mA): The Arduino Integrated Development Environment (IDE) is application (for Windows, macOS, Linux) that is written in functions from C and C++<sup>[2]</sup>. It is used to write and upload programs to Arduino compatible boards.
  - C++ language
  - Blynk (IOT platform): IoT platform to connect your devices to the cloud, design apps to control them, analyze telemetry data, and manage your deployed products at scale

#### c) Hardware used

- Solar panels:

The term solar panel is used colloquially for a photovoltaic (PV) module. A PV module is an assembly of photovoltaic cells mounted in a frame work for installation. Photovoltaic cells use sunlight as a source of energy and generate direct current electricity. A collection of PV modules is called a PV Panel, and a system of Panels is an Array. Arrays of a photovoltaic system supply solar electricity to electrical equipment. Photovoltaic modules use light energy (photons) from the Sun to generate electricity through the effect. Here the nominal voltage is 24V and the number of cells in solar panel module is 36.



Figure 1: Solar panel

- Battery

A battery is a device consisting of one or more electrochemical cells with external connections for powering electrical devices such as flashlights, mobile phones, and electric cars. When a battery is supplying electric power, its positive terminal is the cathode and its negative terminal is the anode. The terminal marked negative is the source of

electrons that will flow through an external electric circuit to the positive terminal. When a battery is connected to an external electric load, a redox reaction converts high-energy reactants to lower-energy products, and the free-energy difference is delivered to the external circuit as electrical energy.

Batteries come in many shapes and sizes, from miniature cells used to power hearing aids and wristwatches to small, thin cells used in smartphones, to large lead acid batteries or lithium-ion batteries in vehicles, and at the largest extreme, huge battery banks the size of rooms that provide standby or emergency power for telephone exchanges and computer data centres.

Batteries have much lower specific energy (energy per unit mass) than common fuels such as gasoline. Here in this project 12V battery is used as shown in fig. 2.



Figure 2: 12V Battery

#### d) NodeMCU:

ESP32 is a series of low-cost, low-power system on a chip microcontrollers with integrated Wi-Fi and dual-mode Bluetooth. The ESP32 series employs a Tensilica Xtensa LX6 microprocessor in both dual-core and single-core variations and includes built-in antenna switches, RF balun, power amplifier, low-noise receive amplifier, filters, and power-management modules. ESP32 is created and developed by Espressif Systems, a Shanghai-based Chinese company, and is manufactured by TSMC using their 40 nm process. It is a successor to the ESP8266 microcontroller. ESP32 MCU is shown in below fig. 3.

Features of ESP32:

- Ultra low power (ULP) co-processor.
- CPU: Xtensa dual-core (or single-core) 32-bit LX6 microprocessor, operating at 160 or 240 MHz and performing at up to 600 DMIPS.
- Memory: 520 KiB SRAM.
- Secure boot.
- Flash encryption.
- 1024-bit OTP, up to 768-bit for customers.
- Internal low-dropout regulator.
- Individual power domain for RTC.
- 5µA deep sleep current.
- Infrared remote controller (TX/RX, up to 8 channels).
- Ethernet MAC interface with dedicated DMA and IEEE 1588 Precision Time Protocol support.
- Ultra low power analog pre-amplifier.
- Storage-4Mbytes.



Figure 3: ESP32 MCU

(T = Time and C = the speed of sound)

Features:

- HC-SR04 Power Supply: +5V
- DC Quiescent Current: <2mA
- Working Current: 15mA



Figure 5: Ultrasonic Sensor

**e) DC Series Motor**

The speed controller works by varying the average voltage sent to the motor. It could do this by simply adjusting the voltage sent to the motor, but this an inefficient method. A better way is to switch the motor supply on and off very quickly. If the switching is fast enough, the motor functioning does not get affected, it only notices the average effect

Technical specification

- Operating voltage- 12V
- Operating current-80 mA
- Rpm- 1000 rpm



Figure 4: DC Motor

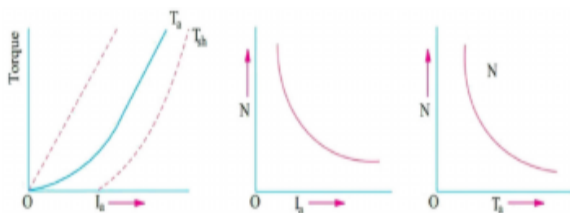

Figure 4: (a) Characteristics of DC Series Motor

**f) Ultrasonic Sensor**

Ultrasonic sensors work by emitting sound waves at a frequency too high for humans to hear. They then wait for the sound to be reflected back, calculating distance based on the time required. This is similar to how radar measures the time it takes a radio wave to return after hitting an object. The fig. 5 shown below is ultrasonic sensor.

To measure the specific distance from your sensor, this can be calculated based on this formula.

$$\text{Distance} = \frac{1}{2} T * C$$

Where,

**g) Moisture Sensor**

Moisture Sensor or Soil sensor shown in below Fig. 6 may be a sensor which faculties those wetness material of the soil. That sensor need just as the plain and the propelled yield. The propelled yield will be created and the plain yield limit might a chance to be fluctuated. It takes a shot on the example about open Also short crazy. That yield may be secondary or low demonstrated toward the headed. During those side of the point when the mud may be dry, those current won't experience it Along these lines it will clear out for Concerning illustration open circuit. During those purpose The point when those dirt is wet, those present will take off from single terminal of the following and the circlet is gathered with make short and the yield will be nothing.

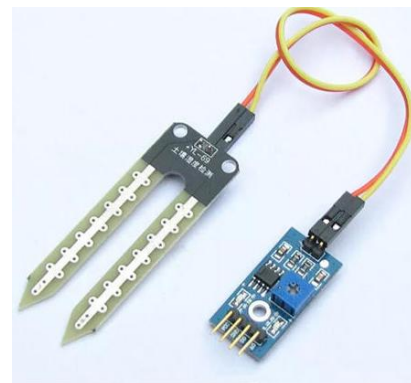

Figure 6: Moisture Sensor

**h) LD293Driver**

L293D is a typical Motor driver or Motor Driver IC which allows DC motor to drive on either direction. L293D is a 16-pin IC which can control a set of two DC motors simultaneously in any direction. It means that you can control two DC motor with a single L293D IC. Dual H-bridge Motor Driver integrated circuit (IC) shown in fig. 8.

It works on the concept of H-bridge. H-bridge is a circuit which allows the voltage to be flown in either direction. As you know voltage need to change its direction for being able to rotate the motor in clockwise or anticlockwise direction, Hence H-bridge IC are ideal for driving a DC motor.

In a single L293D chip there are two h-Bridge circuit inside the IC which can rotate two dc motor independently. Due to its size it is very much used in robotic application for controlling DC motors. Given below is the pin diagram of a L293D motor controller.

There are two Enable pins on L293d. Pin 1 and pin 9, for being able to drive the motor, the pin 1 and 9 need to be high as shown in below fig. 7. For driving the motor with left H-bridge you need to enable pin 1 to high. And for right H-Bridge you need to make the pin 9 to high. If anyone of the either pin1 or pin9 goes low, then the motor in the corresponding section will suspend working. It's like a switch.

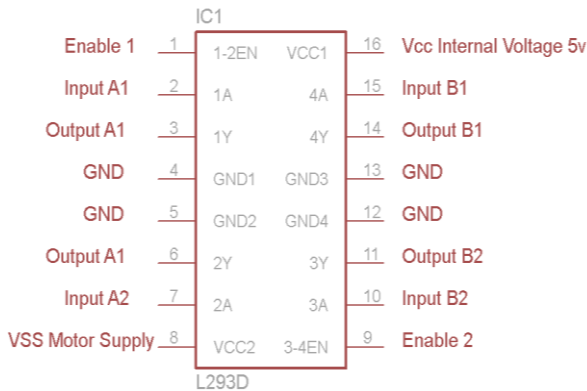

Figure 7: Pin Diagram of L293D Driver

Features of L293D Driver:

- Motor voltage Vcc2 (Vs): 4.5V to 36V.
- Maximum Peak motor current: 1.2A.
- Maximum Continuous Motor Current: 600mA
- Supply Voltage to Vcc1(vss): 4.5V to 7V

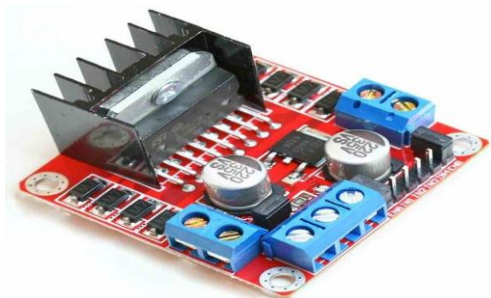

Figure 8: L293D Driver

1) DC Pump Motor

A pump motor is a DC motor device that moves fluids. A DC motor converts direct current electrical power into mechanical power. DC or direct current motor works on the principal, when a current carrying conductor is placed in a magnetic field, it experiences a torque and has a tendency to move. This is known as motoring action. Pumps operate by some mechanism (typically reciprocating or rotary), and consume energy to perform mechanical work by moving the fluid. Pumps operate via many energy sources, including manual operation, electricity, engines, or wind power, come in many sizes, from microscopic for use in medical applications to large industrial pumps.

Features:

- Reduced noise

- Available in DC and AC
- Supply voltage: +12VDC



Figure 9: DC Pump Motor

2) Active Low Relay

A relay is an electrically operated switch as shown below in fig.10 active low relay. It consists of a set of input terminals for a single or multiple control signals, and a set of operating contact terminals. The switch may have any number of contacts in multiple contact forms, such as make contacts, break contacts, or combinations thereof.

Relays are used where it is necessary to control a circuit by an independent low-power signal, or where several circuits must be controlled by one signal. Relays were first used in long-distance telegraph circuits as signal repeaters: they refresh the signal coming in from one circuit by transmitting it on another circuit.

Features

- Working voltage: 5V DC
- Current: 15-20mA per channel

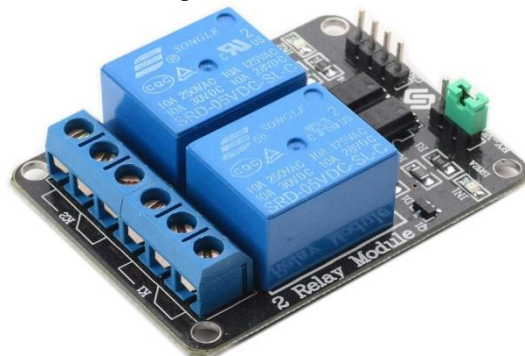

Figure 10: Active Low Relay

10. DC Fan:

Operation Temperature	-10~75 degree C
Storage Temperature	-40~75 degree C
Relative humidity	65% +/-20%
Rated speed	4000 - 5000RPM
Rated voltage	12 V
Max air flow	49.7CFM

3) Working of solar grass cutter

- Coming to the working of solar powered grass cutter, it has panels mounted in a particular arrangement at an angle of 45 degrees in such a way that it can receive solar radiation with high intensity easily from the sun.
- These solar panels convert solar energy into electrical energy. Now this electrical energy is stored in batteries by using a solar charger.
- The main function of the solar charger is to increase the current from the panels while batteries are charging, it also

disconnects the solar panels from the batteries when they are fully charged and also connects to the panels when the charging in batteries is low.

- The motor is connected to the batteries through connecting wires. Between these a two- motor driver is provided. It starts and stops the working of the motor.
- From this motor, the power transmits to the mechanism and this makes the blade to rotate with high speed and this makes to cut the grass.
- The intended controller consists of five behaviors running concurrently. These behaviors, on getting stimuli from environment will appropriately react to modify the motor actions of robot. The robot initially starts wandering in the workspace, which is the basic behavior of robot. Robot keeps moving without any change in its direction until it perceives an obstacle or finds the goal.
- The robot uses sonar ranger to detect the presence of obstacles and executes obstacle avoidance behavior. It continues searching for goal, which is grass field and as it finds it, starts moving towards that.
- And the efficiency of our project is will be more than 80 %.

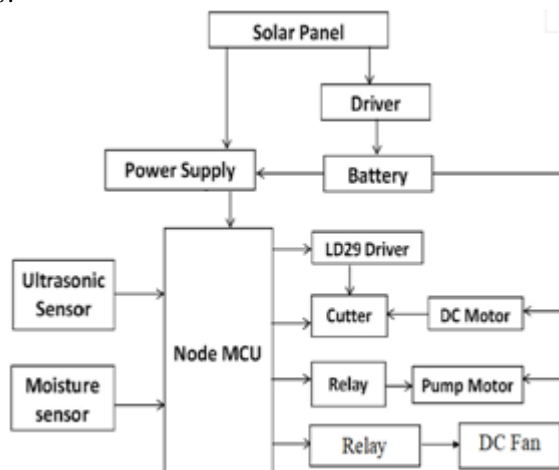

Figure 11: Block Diagram

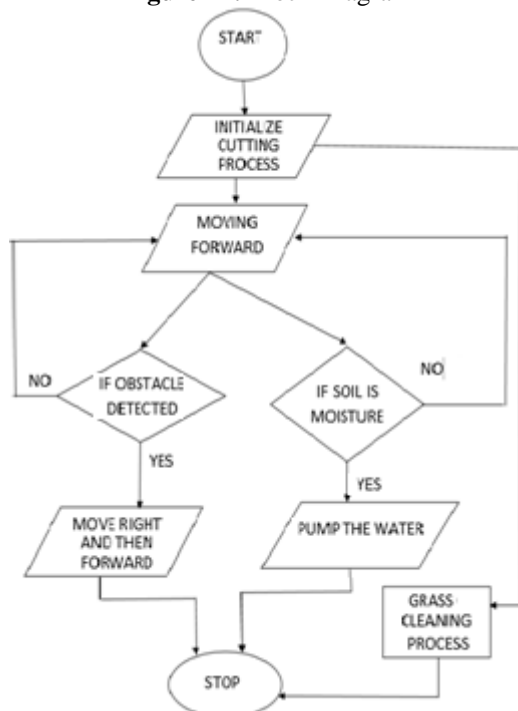

Figure 12: Flow Chart

## 5. Proposed Work

- Automated solar grass cutter is a fully automated grass cutting robotic vehicle powered by solar energy that also avoids obstacles and is capable of fully automated grass cutting, without the need of any human interaction.
- The system uses 12V batteries to power the vehicle movement motors as well as the grass cutter motor.
- The Blade is kept at the Angle of 90 Deg for flexible operation.
- We also use a solar panel to charge the battery so that there is no need of charging it externally.
- The grass cutter and vehicle motors are interfaced to an ESP32 microcontroller that controls the working of all the motors.
- The microcontroller moves the vehicle motors in forward direction in case no obstacle is detected.
- On obstacle detection, ultrasonic sensor monitors it and the microcontroller thus moves towards right and stops within 3sec to avoid any damage to the object/human/animal.
- Microcontroller then turns the vehicle until it gets clear of the object and then moves the grass cutter in forward direction again.
- Assembling is easy

## Advantages

- No fuel consumption
- Compact size and portable
- Operating principle is simple
- Non-skilled person can also operate this machine
- No pollution

## 6. Results

The following results have made from this project:

- The set of motors are used for the movement of the grass cutter.
- An ultrasonic sensor avoids obstacles and provides safety to the cutter.
- Combination of moisture sensor and water pump takes care of the soil moisture.

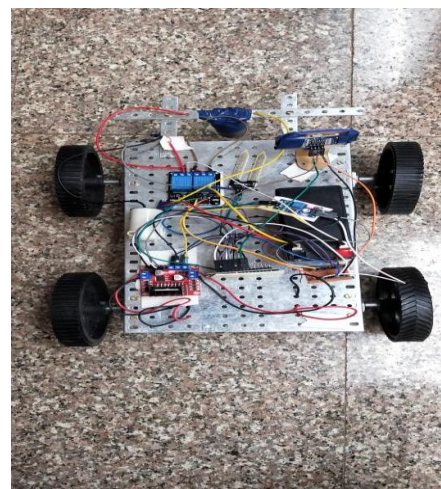

Figure 12: Mobile Robot



Figure 13: App Controller

## 7. Conclusion

Our paper entitled Manufacturing of solar powered grass cutter is successfully completed and the results obtained are satisfactory. It will be easier for the people who are going to take the project for the further modifications. This project is more suitable for a common man as it is having much more advantages i.e, no fuel cost, no pollution and no fuel residue, less wear and tear because of less number of moving components and this can be operated by using solar energy. This will give much more physical exercise to the people and can be easily handled. This system is having facility of charging the batteries while the solar powered grass cutter is in motion. So it is much more suitable for grass cutting also. The same thing can be operated in night time also, as there is a facility to charge these batteries in day light.

The project which we have done surly reaches the average families because the grass can be trimmed with minimum cost and with minimum time Finally this project may give an inspiration to the people who can modify and can obtain better results.

## References

- [1] Ms. YadavRutuja A., Ms. ChavanNayana V., Ms. Patil Monika B., Mr. V. A. Mane, "AUTOMATED SOLAR GRASS CUTTER" February 2017 IJSDR Volume 2, Issue 2
- [2] Vicky Jain, SagarPatil, PrashantBagane, Prof. Mrs. S.S. Patil, "Solar Based Wireless Grass Cutter", International Journal of Science, Technology and Engineering, Vol.2,2016,2349-784X.
- [3] Sultan Mohyuddin, Digesh K D, Vivek T K, NazeyaKhanam F and Vidyashree H V, "Automatic Grass Cutter", International Journal of Science, Technology and Engineering, Vol.2,2017,2349-784X.
- [4] Praful P. Ulhe, Manish D. Inwate, Fried D. Wankhede and Krushankumar S. Dhakle, "Modification of Solar Grass Cutting Machine", International Journal for Innovative Research in Science and Technology, Vol.2,2018,2349-6010