

# LPG Gas Leakage Monitoring and Alert System using Arduino

Ayesha Siddika<sup>1</sup>, Imam Hossain<sup>2</sup>

<sup>1</sup>Faculty, Dept. of CSE, World University of Bangladesh (WUB), Bangladesh

<sup>2</sup>MSc. in CSE, Daffodil International University (DIU), Bangladesh

**Abstract:** *The explosion due to gas leakage has become a serious problem in our country's daily activities. Now the world is evolving with technology, so it is necessary to use technology if possible in every case. LPG gas to resolve the accident occurred we can prevent it through technology. The system is based on a microcontroller, which uses gas sensors as well as GSM, display and buzzer. It is designed for LPG Gas Leakage Monitoring and Alert System using Arduino Mega with MQ135 sensor. This circuit contains MQ135 gas sensor, microcontroller, buzzer, display and GSM. The sensor will detect the gas leakage and transmit the information to the microcontroller. On the basis of those information, the microcontroller makes a decision and then displays a warning message on the display and the message will be sent to the user via GSM. The uses of the Arduino microcontroller with Arduino, provide a suitable platform for implementing an embedded control system and it is possible to modify it to meet our future requirements easily and quickly.*

**Keyword:** LPG Gas Leakage, Monitoring, Security, Gas sensor, GSM module, Microcontroller

## 1. Introduction

LPG Gas leaks have been increased from 0.72% of all kitchen accidents to 10.74% of all the kitchen accidents. The small LPG cylinder of weight 5kg in which the burner is located immediately over the cylinder without using a rubber tube is seen to be safer than the one which uses a rubber pipe as this subway has the hazards of getting cracked which in turn can make way to leakage. A computer program to run online to detect the leakage locations has been originated and it functions as the automatic supervisor of the pipelines in remote areas. Simple Gas leak detector is a simple device which is used to detect the leakage of gas and if the gas leak occurs, an equivalent message is conveyed by the means of an LCD screen and a buzzer and with the help of the GSM module it is capable to broadcast messages to the stakeholders about the LPG leak.

This device is at its initial level of development and with modification in future this device will also trip off the mains supply to ensure better safety and surety. The gas leak detector device can find application not only at residential homes but also it is applicable to hotels, restaurants and even in industries where LPG gas is used for some or the other purposes.

### Objectives

- To design and develop a LPG Gas leakage monitoring & alert system using Arduino.
- To display the leakage alarm on a display board and send an alarm notification on SMS to any predefined mobile number.

### Justification of Study

LPG gas leakage problem increasing day by day for the reason, designed and develop a system of LPG Gas leakage monitoring and alert system using Arduino. So this IOT based

system award people to prevent accidents and safe from damage.

### Scope of Study

Due to the increase in fuel costs, we use LPG gas in most petrol/diesel vehicles. The use of LPG gas in car and home is very risky. The LPG gas cylinders used at home and elsewhere are the same condition, which is mainly due to LPG gas leakage accidents. For the protection and security of LPG gas explosion problem, we design the IoT based system to prevent home and vehicle accidents.

## 2. Literature Review

Microcontroller Based LPG Gas Leakage Detector Using GSM Module, in this system where used gas sensor, GSM module, microcontroller, if the gas concentration is increases the gas sensors will sense the leakage of the gas and then send to the microcontroller. Then the GSM module is connected to the microcontroller which will gives the command to stop the main supply. The system is highly reliable, tamper-proof and secure. In the long run the maintenance cost is efficient. It is highly accurate. (A.sood, B.Sonkar, A.Ranjan, Mr. A.Faisal, June-2015)

Liquefied Petroleum Gas commonly known as LPG consists of a mixture of Commercial Propane and Commercial Butane having saturated as well as unsaturated hydrocarbons. It is an odorless gas due to which Ethyl Mercaptan is added as powerful odorant so that leakage can easily be detected. LPG is commonly used in homes for heating and cooking. This energy source is primarily composed of propane and butane which are highly flammable chemical compounds. LPG was first produced in 1910 by Walter Snelling (Didpaye1, 2015) and is classified as a hazardous material because of its flammable properties and explosive potential when stored

under pressure. Before the development of electronic household gas detectors in the 1980s and 90s, gas presence was detected with a chemically infused paper that changed its color when exposed to the gas (Didpaye1, 2015). Since then, many technologies and devices have been developed to detect, monitor, and alert the leakage of a wide array of gases. Hence the requirement of an efficient system to detect leakage of LPG is inevitable, which may be used for domestic and commercial purposes.

A system, that provided security issues against thieves, leakage and fire accidents. In those cases, this system sends SMS to the emergency number provided to it. In the proposed system we have designed “LPG gas monitoring and automatic cylinder booking with alert system”. These report focus on detection of economic fuels like petroleum, liquid petroleum gas, in the proposed system we have designed “LPG gas monitoring and automatic cylinder booking with alert system”. These report focus on detection of economic fuels like petroleum, liquid petroleum gas, and alert system”. These report focus on detection of economic fuels like petroleum, liquid petroleum gas, alcohol etc. (H.Rawat, A.Kushwah, K.Asthana, AShivhare,2014)

Liquefied petroleum gas (LPG) is a highly flammable chemical. The mixture of hydrocarbon gas (LPG) is used as fuel for burning, at home and in the industry. LPG is used as a domestic fuel, industrial, heating and so on. A heater and gas sensitive resistor are some of the internal components of the sensor used to avoid failure leading to a false alarm indication. The alarm gets triggered when a certain concentration of gas is exceeded by steam. This device is used to indicate early warning of a problem to ensure public safety. LPG and gas sensors are used in the field of safety, health and materials. This embedded system is used to detect hazardous gas and to alert uses by sending an SMS.(A.Shiyana,Mrs.R Deepa, October,2017).

The Microcontroller that is utilized for the project is Arduino Uno R3. R3 is the 3rd and latest revision of Arduino Uno. The Arduino Uno is a microcontroller board that is based on ATmega328. The ATmega328 is a single microchip controller that has 32 Kbytes (with 0.5 Kbyte which is occupied through the boot loader). Moreover, it comprises of SRAM and EEPROM that can be written and read with the EEPROM library, I/O pins, AVR microcontroller chip, a power jack, a USB connection, ICSP (In-Circuit System Programming header), and the reset button. Simply, it is connected to a computer via USB cable. The Clock speed of the Arduino is 16 MHz; thus it performs a specific task quicker than other processors or controllers. AVR chip is continuously clocking on 16 MHz regardless to what a code is performing, it never halts; thus its current’s consumption is essentially independent from the code that is executed. (Dr. Bayan M. Sabbar, A I. Ali June-2016).

This paper discusses about the design of gas leakage detector. To detect Gas Leakage (like LPG leak, Butane leak, Methane leak) or any such petroleum based gaseous substance that can

be detected using MQ5 Sensor. Setup an SMS based Alert Mechanism and send 3 SMS (3 alert messages) to 2 specified mobile numbers (input inside the Arduino program). Produce a sound alarm upon gas leak and stop the alarm once gas leak is under control (gas presence in atmosphere is under normal range). Displays status in an LCD using a (16×2) LCD module. (A. Beliraya, December 2018.)

### 3. Methodology

Methodology is the systematic, theoretical analysis of the methods applied to a field of study. It comprises the theoretical analysis of the body of methods and principles associated with a branch of knowledge. Typically, it encompasses concepts such as paradigm, theoretical model, phases and quantitative or qualitative techniques. A methodology does not set out to provide solutions—it is therefore, not the same as a method. Instead, a methodology offers the theoretical underpinning for understanding which method, set of methods, or best practices can be applied to a specific case. Through a methodology, we are achieving the knowledge about planning, design, and implementation and testing.

#### 3.1 Description of Methodology

In the project we follow workflow for whole project work. This workflow is divided into 6 steps. These are following

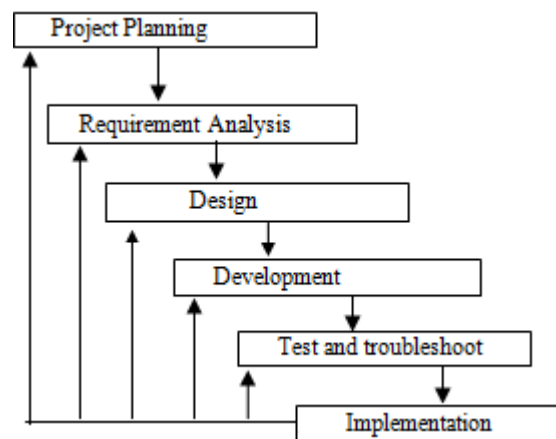

Figure 1: Workflow for this project

#### Requirement Analysis, Design & Development

The main objective of our project is to ensure the LPG gas leakage and provide a signal at that time, as well as through SMS and signal to the specified mobile number. Once we are integrated with the various functions of architecture and GPS system, it is time to design the hardware and develop our concept.

#### System Requirements

The system we want to make is consisting of Arduino, GSM module, Buzzer, LCD. GSM module send the SMS to mobile number, The Arduino will control the signal as well as process the information received from the GSM. These are the

following hardware and software requirements, which are needed to run this project successfully.

**Hardware Requirements**

- 1) Arduino UNO Microcontroller
- 2) 16x2 LCD Display
- 3) 12v dc power supply
- 4) 5v Regulated CKT
- 5) Buzzer
- 6) LPG Gas sensor
- 7) GSM Module
- 8) GSM Sim
- 9) Connecting wires
- 10) Project base.

**Software Requirements**

- 1) Arduino IDE
- 2) Language C++

**Flowchart**

Flowchart in a logical sequence, or structure is a graphical representation of a production process. The purpose of a flow chart of the process of working with a project or a common language or reference point is provided.

**3.2 Block Diagram**

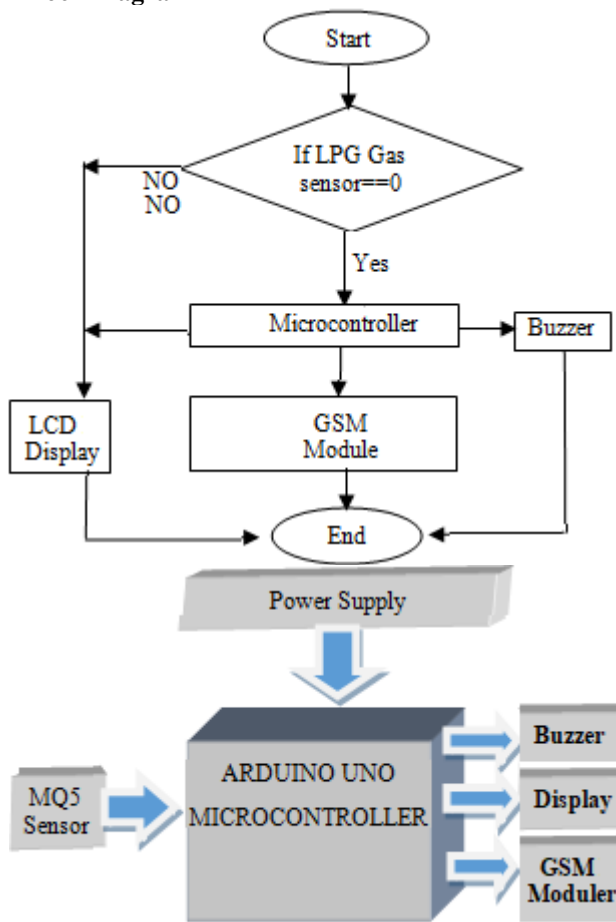

**Figure 2:** Block Diagram of LPG Gas Leakage Monitoring and Alert System using Arduino

Initially, the microcontroller send signal to the GSM module and if the GSM module is connected properly with the microcontroller it sends an acknowledgement signal back to the microcontroller. Then if there is any gas leakage in the MO sphere it is detected by the gas sensor unit using MQ-6sensor. After the sensor unit detects the gas leakage, a signal is sent to the ADC unit of the microcontroller which then sends activation signal to other external devices connected to it such as buzzer, GSM module and LCD display.

**3.3 Circuit Diagram**

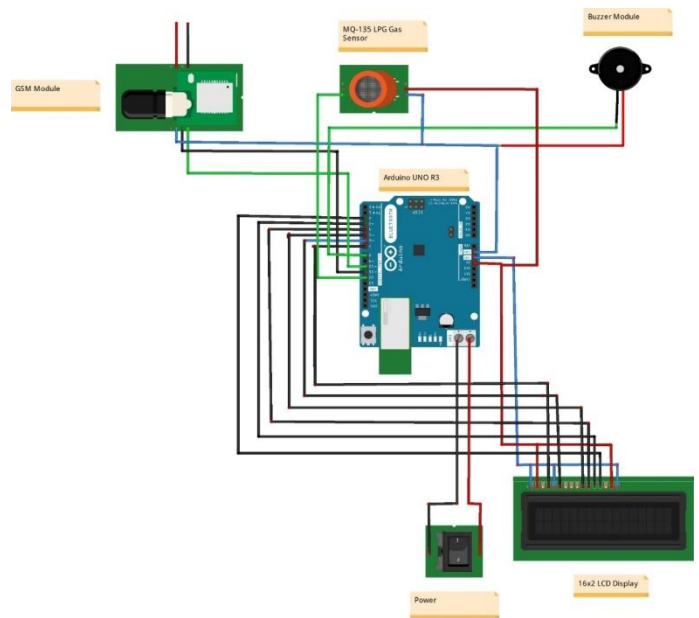

LPG gas sensor module's DO pin is directly connected to pin 12 of Arduino and Vcc and GND are connected to Vcc and GND of Arduino. LPG gas sensor module consist a MQ3 sensor which detects LPG gas. A comparator circuit is used for converting Analog output of MQ3 in digital. A 16x2 LCD is connected with Arduino in 4-bit mode. Control pin RS, RW and directly connected to Arduino pin 2, GND and 3. And data pin D0-D7 are connected to 4, 5, 6, 7 of Arduino. A buzzer is connected with Arduino pin number 8 through a NPN BC547 transistor having a 4.7 kilo ohm resistor at its base.

**3.4 Project Description**

LPG Gas leakage monitoring and alert system .

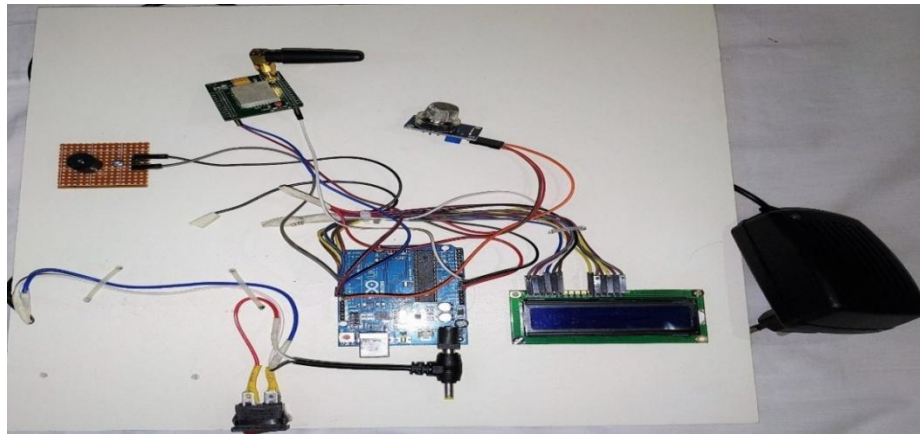

**Figure 3:** LPG Gas leakage monitoring and alert system using Arduino

The Complete Connection Diagram consists of the Microcontroller Circuit, GSM Module, Power Supply, GAS Sensor Module and Buzzer. The Power Supply is fed to the GSM Module. The output of the sensor goes low as soon as the MQ-5 Gas Sensor senses any gas leakage from the storage. This is detected by the microcontroller and the LED & buzzer are turned ON. The microcontroller continues sending message as "GAS LEAKAGE" to a pre-defined mobile number using GSM Module.

#### Working Principles

Arduino will be active with 5 volts' power supply. The sensor will detect gas leakage once the system is launched, if there is no gas leakage, it will display "Normal Condition Air Cleaning" on the display. If the gas is leaked otherwise, the following three steps will follow

Step 1: A signal from the microcontroller will go to the display and show gas leakage message there.

Step 2: The signal from Buzzer will signal when the first step is completed.

Step 3: Lastly, through GSM, there will be a signal message that the gas has been leaked to a specific number or multiple.

#### 4. Conclusion

Its ability to warn its stakeholders about the leakage of the LPG gas. The future aspects of this detector include the GSM module and a tripper circuit which increases the efficiency of the system and provides more safety to the users. This detector is implemented successfully and is easy to use and also a low cost product. Another advantage of this device is that even though if no one is there in the house and then gas leaks occurs, GSM module is there to send immediate messages to the stakeholders regarding the gas leak and thus it lowers the intensity of accidents. GSM module in this device ensures better safety regarding the gas leaks.

#### 5. Limitation

Gas may be leaked at various levels in various factories or homes, requiring additional gas sensors to detect it.

#### 6. Future Work

A mobile gas sensing robot can be constructed to sense the leakage of gas through pipelines as the robot can move on a track which is situated along the length of pipeline.

#### References

- [1] A Shrivastava, R Prabhaker, R Kumar, R Verma, "GSM based gas leakage detection system." International Journal of Emerging Trends in Electrical and Electronics, vol. 3, no. 2, pp. 42-45, 2013.
- [2] Attia, Hussain A., and Halah Y. Ali. "Electronic Design of Liquefied Petroleum Gas Leakage Monitoring, Alarm, and Protection System Based on Discrete Components." International Journal of Applied Engineering Research, vol. 11, no. 19, pp. 9721-9726, 2016.
- [3] Apeh, S. T., K. B. Eramah, and U. Iruansi. "Design and Development of Kitchen Gas Leakage Detection and Automatic Gas Shut off System." Journal of Emerging Trends in Engineering and Applied Sciences, vol. 5, no. 3, pp. 222-228, 2014.
- [4] Mahalingam, A., R. T. Naayagi, and N. E. Mastorakis. "Design and implementation of an economic gas leakage detector." Recent Researches in Applications of Electrical and Computer Engineering, pp. 20-24, 2012.
- [5] Phalak; Kowekar; & Joshi. 2015. International Journal for Research In Emerging Science And Technology, Vol. 1.2, Issue 9.
- [6] Pranjali Ingale Patil; priyanka Barhate; Bhagyashri Nemade; & vijay D- club {hari'2017' using Arduino 'International Research Journal of Engineering and Technology GRIET' Vol' 04 Issue: 06
- [7] S.Verma, A.Das, S. Dey, P. Chowdhury, Automatic Temperature Controlled Fan Using Thermistor, ISSN:2321-1156 International Journal of Innovative Research in Technology & Science(IJIRTS) July 2016.