

Damping Out Power System Oscillations for LLL-Fault in Multi-Area Power System Using Static Synchronous Series Compensator (SSSC)

A. Praveena

Department of Electrical Engineering SANK (AP), India

Abstract: *The main aim of this paper is to damp out power system oscillations, which has been recognized as one of the major concerns in power system operation. In a Static Synchronous Series Compensator (SSSC), a controllable AC voltage is generated by a voltage-source converter. There are two control channels for controlling the magnitude and phase of the voltage. This paper describes the damping of power oscillations by static synchronous series compensator (SSSC) based damping controllers. The advantage of this approach is that it can handle the nonlinearities, at the same time it is faster than other conventional controllers and it improve the reactive power of the system. Simulation studies are carried out in Matlab/Simulink environment to evaluate the effectiveness of the proposed Static synchronous series compensator (SSSC) of multi-area power system. Results show that the proposed SSSC based damping controllers improve the damping performance of the in the event of a major disturbance.*

Keywords: Flexible AC Transmission System (FACTS), Static Synchronous Series Compensator (SSSC), Power Oscillation Damping (POD) controller.

1. Introduction

During the last decade, a number of control devices under the term FACTS technology have been proposed and implemented. Application of FACTS devices in power systems, leads to better performance of system in many aspects [1-5]. Voltage stability, voltage regulation and power system stability, damping can be improved by using these devices and their proper control.

There are various forms of FACTS devices, some of which are connected in series with a line and the others are connected in shunt or a combination of series and shunt. The FACTS technology is not a single high power controller but rather a collection of controllers which can be applied individually or in coordination with other to control one or more of the inter related system parameters like voltage, current, impedance, phase angle and damping of oscillations at various frequencies below the rated frequency.

Among all FACTS devices, **static synchronous series compensators** (SSSC) plays much more important role in reactive power compensation and voltage support because of its attractive steady state performance and operating characteristics[6-7].

The power system is a highly nonlinear system that operates in a constantly changing environment; loads, generator outputs, topology, and key operating parameters change continually [8-9]. When subjected to a transient disturbance, the stability of the system depends on the nature of the disturbance as well as the initial operating condition. The disturbance may be small or large. Small disturbances in the form of load changes occur continually, and the system adjusts to the changing conditions. The system must be able to operate satisfactorily under these conditions and successfully meet the load demand. It must also be able to survive numerous disturbances of a severe nature, such as short-circuit on a transmission line or loss of a large

generator. Oscillations of generator angle or line angle are generally associated with transmission system disturbances and can occur due to step changes in load, sudden change of generator output, transmission line switching, and short circuits[10-11]. Depending on the characteristics of the power system, the oscillations may last for 3-20 seconds after a severe fault. Drawn out oscillations that last for a few seconds or more are usually the result of very light damping in the system and are pronounced at power transfers that approach the line's stability limit. During such angular oscillation period, significant cycle variations in voltages, currents, and transmission line flows will take place. It is important to damp these oscillations as quickly as possible because they cause mechanical wear in power plants and many power quality problems. The system is also vulnerable if further disturbances occur. To improve the voltage stability and the damping of oscillations in power systems, supplementary control laws can be applied to existing devices. These supplementary actions are referred to as voltage stability and power oscillation damping (POD) control. In this work, voltage stability and POD control has been applied to Static synchronous series compensator (SSSC).The SSSC using a voltage source converter to inject a controllable voltage in quadrature with the line current of a power network is able to rapidly provide both capacitive and inductive impedance compensation independent of the power line current[12-14]. Moreover, a SSSC with a suitably designed external damping controller can be used to improve the damping of the low frequency power oscillations in a power network. These features make the SSSC an attractive FACTS device for power flow control, power oscillation damping and improving transient stability.

In this paper, the damping performance of a two-machine power system is compared for the cases of with and without SSSC based damping controllers in the event of a 3-phase short circuit faults and 2-phase ground faults. Simulation results show that in damping power system oscillations, the SSSC with POD controller is more effective than the SSSC

Volume 8 Issue 3, March 2019

www.ijsr.net

Licensed Under Creative Commons Attribution CC BY

without POD controller.

2. Power System under Study

To design and optimize the SSSC-based damping controller, a multi-area power system with SSSC, shown in Fig.1, is considered. It is similar to the power systems used in references. The system consists of two generators divided in two subsystems and are connected via an intertie. Following a disturbance, the two subsystems swing against each other resulting in instability. To improve the stability the line is sectionalized and a SSSC is in between the bus-line 1 and 2. In the Figure, G_1 and G_2 represent the generators; T/F_1 and T/F_2 represent the transformers in the bus-line 1 and bus-line 2 respectively.

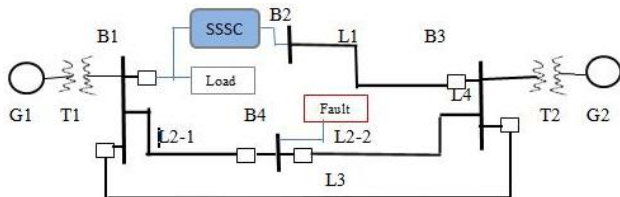

Figure 1: Single line diagram of a two-machine power system with SSSC

The SSSC injected voltage reference is normally set by a POD (Power oscillation damping) controller. In general, the structure of a FACTS POD controller is shown in Fig.2. It involves a transfer function consisting of an amplification block, a washout block and two lead-lag blocks and an output limiter. Commonly, the local signals of FACTS devices are always applied for the damping control. The inputs to the POD controller are the voltage at bus B1 and the current flowing in the line L1.

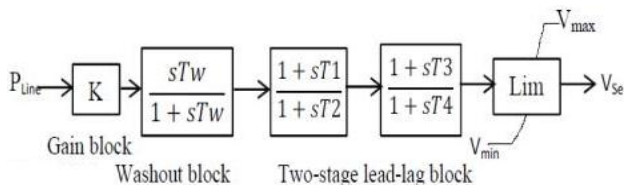

Figure 2: The structure of a simple FACTS POD controller

3. Basic Operating Principles of SSSC

Below Fig.3 shows a functional model of the SSSC where the dc capacitor has been replaced by an energy storage device such as a high energy battery installation to allow active as well as reactive power exchanges with the ac system. It comprises a voltage source inverter and a coupling transformer that is used to insert the ac output voltage of the inverter in series with the transmission line. The SSSC's output voltage magnitude and phase angle can be varied in a controlled manner to influence power flows in a transmission line. The phase displacement of the inserted voltage V_{pq} , with respect to the transmission line current I_{line} , determines the exchange of active and reactive power with the ac system.

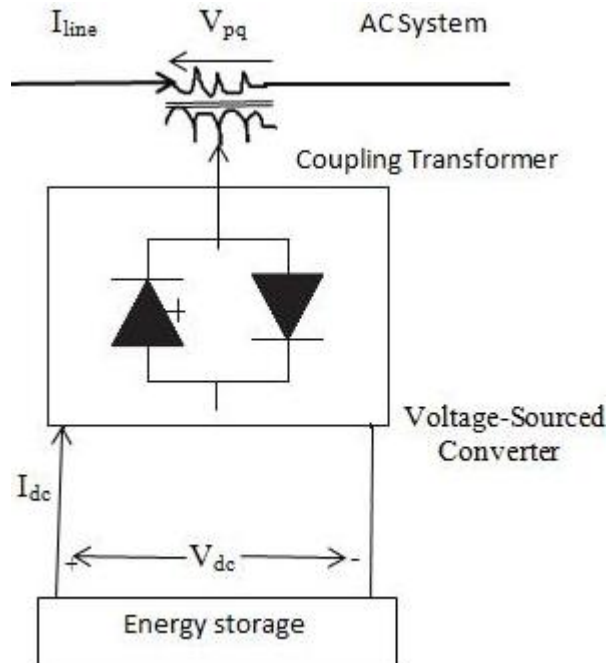

Figure 3: Functional model of SSSC

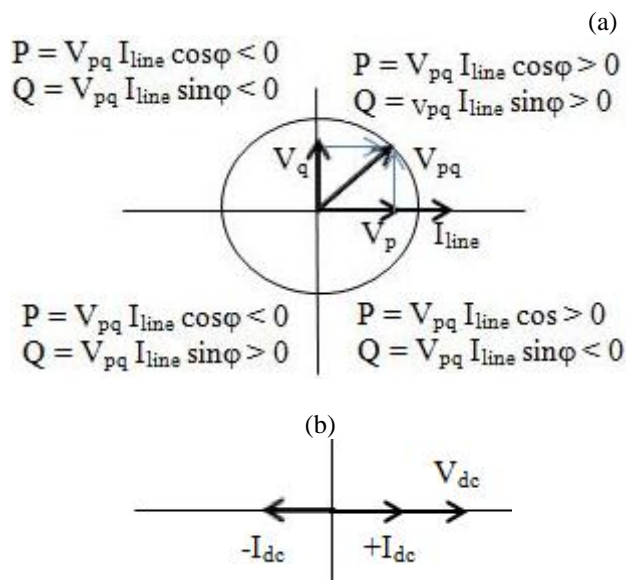

Figure 4: SSSC phasor diagram

Theoretically, SSSC operation in each of the four quadrants is possible, Theoretically, SSSC operation in each of the four quadrants is possible, but there are some limitations to the injected SSSC voltage due to operating constraints of practical power system.

In capacitive mode, the injected SSSC voltage is made to lag the transmission line current by 90° ; in this case, the SSSC operation is similar to the operation of a series capacitor with variable capacitance kX_c , i.e., $V_{pq} = -j k X_c I_{line}$, where k is a variable.

3.1 Rating of the SSSC

The SSSC can provide capacitive or inductive compensating voltage independent of the line current. The VA rating of the SSSC (solid-state inverter and coupling transformer) is simply the product of the maximum line current (at which

compensation is still desired) and the maximum series compensating voltage: $V_A = I_{max} V_{max}$. An SSSC of 1 p.u. VA rating covers a control range corresponding to 2 p.u. compensating VARs, that is the control range is continuous from -1 p.u. (inductive) VARs to +1 p.u. (capacitive) VARs.

3.2 Internal Controls

From the standpoint of output voltage control, converters may be categorized as “directly” and “indirectly” controlled. For directly controlled converters both the angular position and the magnitude of the output voltage are controllable by appropriate valve (on and off) gating. For indirectly controlled converters only the angular position of the output voltage is controllable by valve gating; the magnitude remains proportional to the dc terminal voltage. The control method of maintaining a quadrature relationship between the instantaneous convertervoltage and line current vectors, to provide reactive series compensation and handle SSR, can be implemented with an indirectly controlled converter. The method of maintaining a single frequency synchronous (i.e. fundamental) output independent of dc terminal voltage variation requires a directly controlled converter. Although high power directly controlled converters are more difficult and costly to implement than indirectly controlled converters (because their greater control flexibility is usually associated with some penalty in terms of increased losses, greater circuit complexity, and/or increased harmonic content in the output), nevertheless they can be realized to meet practical utility requirements.

4. Test System Description

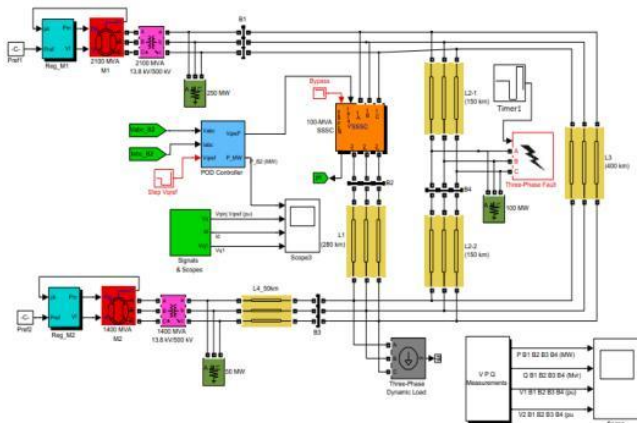

Figure 5: Static Synchronous Series Compensator (SSSC) used for power oscillation damping

In this paper, the SSSC is used to damp power oscillation on a power grid following a three-phase fault which is more severe. The power grid consists of two power generation substations and one major load centre at bus B3. The first power generation substation (M1) has a rating of 2100 MVA; representing 6 machines of 350 MVA and the other one (M2) has a rating of 1400 MVA, representing 4machines of 350 MVA. The load centre of approximately 2200 MW is modelled using a dynamic load model where the active & reactive power absorbed by the load is a function of the system voltage. The generation substation M1 is connected to this load by two transmission lines L1, L2 and L3. L1 is 280-km long and L2 is split in two segments of 150 km each in order to simulate a three-phase

fault and L-L-G fault (using a fault breaker). The generation substation M2 is also connected to the load by a 50-km line (L4). When the SSSC is bypass, the power flow towards this major load is as follows: 664 MW flow on L1 (measured at bus B2), 563 MW flow on L2 (measured at B4) and 990 MW flow on L4 (measured at B3). The SSSC, located at bus B1, is in series with line L1.

5. Simulation and Results

The simulation results are mainly divided two sections. Thus, Section A discusses results for SSSC Dynamic responses for three-phase solid fault without and with POD controller. The results obtained for the test system with three-phase solid fault at Bus 4 without and with phase controlled SSSC are presented in Section B.

A. SSSC Dynamic Responses

Initially V_{qref} is set to 0pu; at $t = 3s$, V_{qref} is set to -0.08pu (SSSC inductive); then at $t = 9s$, V_{qref} is set to 0.08pu (SSSC capacitive). Also, the fault breaker will not operate during the simulation. In below Fig.6, the first graph shows the active power flow P_B2 on line L1, measured at bus B2. The second graph shows the V_{qref} signal along with the measured injected voltage by the SSSC. The third graph shows the I_d current of SSSC and fourth graph shows the magnitude of V_q . We see on the transmitted power (P_{B2} signal) so, we reduce the "Maximum rate of change for V_{qref} (pu/s)" from 3 to 0.08. A 70 MVar 30 kV SSSC is inserted in the test system between Bus 1and Bus 2, in series with the transmission line with higher impedance.

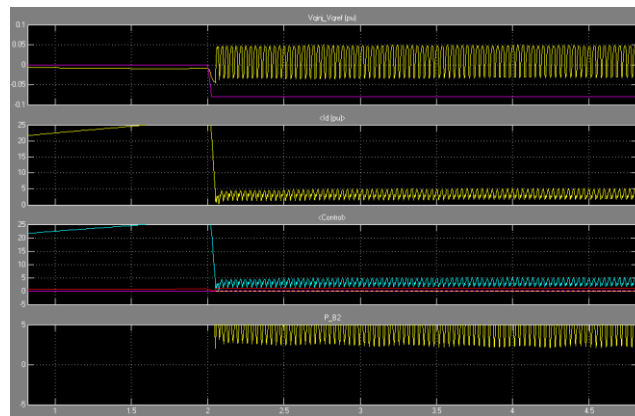
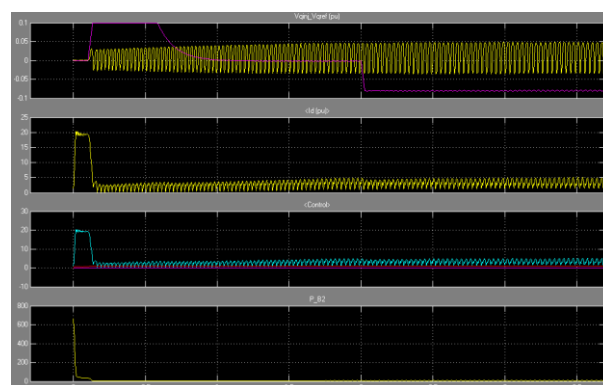

Figure 6 (a): Dynamic response of SSSC for LLL fault without POD controller



Case (b): LLL fault with POD controller

B. Test system simulated waveform

In this test, simulation is performed without and with SSSC controller. Below Fig.7 indicates a three-phase solid fault are applied at Bus 4 that its transition times should be set as follows: [50/50 100/50]; this means that the fault will be applied at 2s and will last for 50 cycles. The simulation shows active power, reactive power, magnitude and phase of voltage at bus B1, B2, B3 and B4 respectively in each Fig.7.

6. Conclusion

In this paper, the simulation of a two-machine power system model with Static synchronous series compensator (SSSC) based damping controllers in the presence of a three-phase short circuit fault. The results show that the power system oscillations are damped out very quickly with the help of SSSC based damping controllers in few seconds. The studies, which include detailed techniques of twelve-pulse and PWM controlled SSSC, are conducted and the control circuits are presented. The SSSC operating conditions and constraints are compared to the operating conditions of other FACTS devices, showing that the SSSC offers several advantages over others. The dc voltage pre-set value in PWM-based controllers has to be carefully selected. As the modulation ratio lies between zero and one, the dc voltage should not be lower than the maximum of the requested SSSC output phase voltage in order to obtain proper control. On the other hand, if the dc side voltage is too high, the rating of both the GTO valves and dc capacitor has to be increased, which means higher installation costs. Not only that, a higher dc side voltage means a lower amplitude modulation ratio and the lower modulation ratio results in higher harmonic distortion. Phase control allows the dc voltage to change according to the power system conditions, which is clearly advantageous, but it requires a more complicated controller and special and costly series transformers. The results show that the use of SSSC is having improved dynamic response and at the same time faster than other conventional controllers. Moreover, this approach is also simple and easy to be realized in power systems.

Appendix

A complete list of parameters used appears in the default options of Sim Power Systems in the above block diagram model. All data are in p.u. unless specified otherwise.

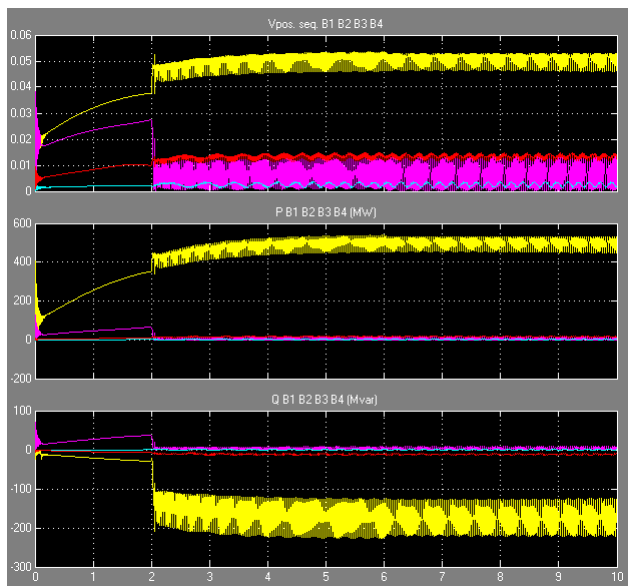

Figure 7(a): Simulated wave form for LLL fault without POD controller

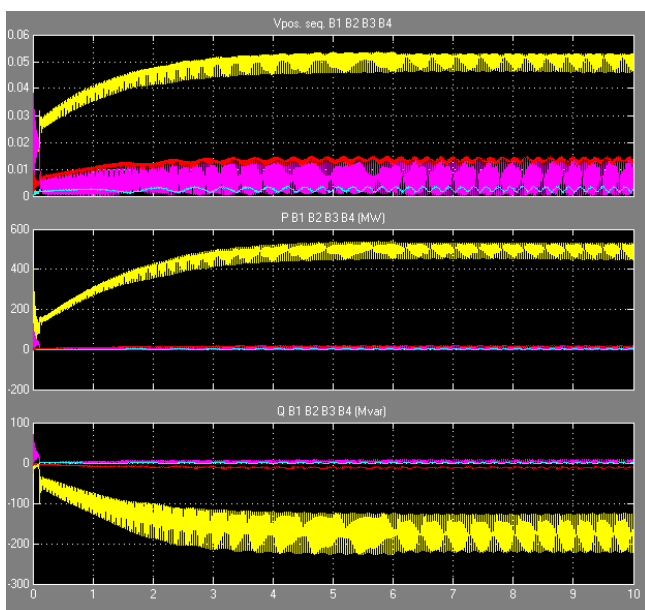

Figure 7(b): Simulated wave form for LLL fault with POD controller

Generator	$S_{B1} = 2100\text{MVA}, S_{B2} = 1400\text{MVA}, V_B = 13.8\text{kV}, f = 50\text{Hz}, X_d = 1.305, X'_d = 0.296, X''_d = 0.252, X_q = 0.474,$ $X'_q = 0.243, X''_q = 0.18, T_d = 1.01\text{s}, T'_d = 0.053\text{s}, T_{d0} = 0.1\text{s}, P_{e1} = 0.3048, P_{e2} = 0.2095, R_s = 2.8544e^{-3}, H = 3.7\text{s}, P = 32$
Loads	Load1 = 250MW + 100MVA, Load2 = 50MW, Load3 = 100MW

Transformer	$S_{BT1} = 2100\text{MVA}$, $S_{BT2} = 1400\text{MVA}$, $13.8/500\text{kV}$, 50Hz , $R_m = 500$, $R_2 = 0.002$, $L_m = 500$, $L_1 = 0$, $L_2 = 0.12$, D1/Yg connection
Transmission Lines	3-Ph, 50Hz , $L_1 = 280\text{km}$, $L_4 = 50\text{km}$, $L_{2-1} = 150\text{km}$, $L_2 = 150\text{km}$, $L_{3-1} = 200\text{km}$, $L_{3-2} = 200\text{km}$, $R_1 = 0.02546\Omega/\text{km}$, $R_0 = 0.3864\Omega/\text{km}$, $L_1 = 0.9337e^{-3}\text{H}/\text{km}$, $L_0 = 4.1264e^{-3}\text{H}/\text{km}$, $C_1 = 12.74e^{-3}\text{F}/\text{km}$, $C_0 = 7.75e^{-3}\text{F}/\text{km}$
Hydraulic Turbine and Governor	$K_a = 3.33$, $T_a = 0.07$, $G_{min} = 0.01$, $G_{max} = 0.97518$, $V_{gmin} = -0.1\text{pu/s}$, $V_{gmax} = 0.1\text{pu/s}$, $R_p = 0.05$, $K_p = 1.163$, $K_i = 0.105$, $K_d = 0$, $T_d = 0.01\text{s}$, $\beta = 0$, $T_w = 2.67\text{s}$
Excitation System	$T_{LP} = 0.02\text{s}$, $K_a = 200$, $T_a = 0.001\text{s}$, $K_e = 1$, $T_e = 0$, $T_b = 0$, $T_c = 0$, $K_f = 0.001$, $T_f = 0.1\text{s}$, $E_{fmin} = 0$, $E_{fmax} = 7$, $K_p = 0$
SSSC	$S_{nom} = 100\text{MVA}$, $V_{nom} = 500\text{kV}$, $f = 50\text{Hz}$, $V_{qmax} = 0.2$, Max. rate of change of $V_{qref} = 3/\text{s}$, $R_{cnv} = 0.00533$, $L_{cnv} = 0.16$, $V_{DC} = 40\text{kV}$, $C_{DC} = 375e^{-6}\text{F}$, $K_{P_IVR} = 0.00375$, $K_{I_IVR} = 0.1875$, $K_{P_VdcR} = 0.1e^{-3}$, $K_{I_VdcR} = 20e^{-3}$

References

[1] N.G. Hingorani, "Flexible AC transmission". IEEE Spectrum, v. 30, n. 4, pp. 40-44, 1993.

[2] N.G. Hingorani and L.Gyugyi, "Understanding FACTS Concepts and Technology of Flexible AC Transmission Systems", IEEE Press, New York, 2000.

[3] Y.H. Song and A.T. Johns, Eds., "Flexible AC Transmission Systems (FACTS)", IEE Press, London, 1999.

[4] R.M. Mathur and R.K. Varma, "Thyristor-Based FACTS Controller for Electrical Transmission Systems", IEEE Press and Wiley Inter-science, New York, 2002.

[5] R. Gru'nbaum, M. Noroozian, and B. Thorvaldsson, "FACTS Powerful systems for flexible power transmission", ABB Rev., May 1999, 4-17.

[6] K. Stahlkopf and M. Wilhelm, "Tighter controls for busier systems", IEEE Spectrum, 1997, 34(4), 48-52.

[7] K.K.Sen, "SSSC-static synchronous series compensator: theory, modelling and applications", IEEE Trans. on Power Delivery, v. 13, n. 1, 1998, pp. 241-246.

[8] K.R. Padiyar, "Power System Dynamics - Stability and Control", Second Edition, Hyderabad: B.S. Publications, 2002.

[9] G. Guo, Y. Wang and D.J. Hill, "Nonlinear output stabilization control of multi-machine power systems", IEEE Trans. on Circuits and Systems, Part I, v. 47, n.1, 2000, pp. 46-53.

[10] K.R. Padiyar, "Analysis of Sub-synchronous Resonance in Power Systems", Kluwer Academic Publishers, Boston, 1999.

[11] F.P. Demello and C. Concordia, "Concepts of synchronous machine stability as affected by excitation control", IEEE Trans. on Power Apparatus and Systems, v. PAS-88, 1969, pp. 316-329.

[12] N.H. Woodley, L. Morgan and A. Sundaram, "Experience with an inverter-based Dynamics Voltage Restorer", IEEE Trans.,

[13] Power Delivery, v. 14, n. 3, 1999, pp. 1181-1186.

[14] P.T. Cheng and R.H. Lasseter, "Dynamic voltage restoration for unbalanced systems", EPRI Conf. on the Future of Power Delivery, Washington, DC, April 9-11, 1996.

[15] J.G. Nielsen, F. Blaabjerg and N. Mohan, "Control strategies for dynamic voltage restorer compensating voltage sags with phase jump", Appl. Power Electron. Conf. Expos, 2001; 2; pp. 1267-1273.

[16] K.R. Padiyar and S.N.P. Anand Kumar, "Control and simulation of DVR for improving power quality", National Power Systems Conf. (NPSC-06), I.I.T. Roorkee, December 2006.

[17] H.W. Van Der Broeck, H.C. Skudelny and G.V. Stanke, "Analysis and realization of a pulsewidth modulator based on voltage space vectors", IEEE Trans., Ind. Appl., v. 24, n. 1, pp. 142-150, 1988.

[18] A. Ghosh and G. Ledwich, "Power Quality Enhancement Using Custom Power Devices", Kluwer Academic Publishers, Boston, 2002.

[19] Sim Power Systems 4.3, User's guide. [Http://www.mathworks.com/products/simpower/](http://www.mathworks.com/products/simpower/)

[20] B.S. Righy and R.G. Harley, "An Improved Control Scheme for a Series-capacitive Reactance Compensator Based on a Voltage- Source Inverter", IEEE Trans. Industry Applications, Vol.34, No.2, 1998, pp.355-363.

[21] L. Sunil Kumar and A. Ghosh, "Modelling and control design of a static synchronous series compensator", IEEE Trans. Power Del., vol. 14, no. 4, pp. 1448-1453, Oct. 1999.

[22] R. Mohan and R. K. Varma, "Thyristor-Based FACTS Controllers for Electrical Transmission Systems", Piscataway, NJ: IEEE Press, 2002.

[23] X.P. Zhang, "Advanced modelling of the multi-control functional static synchronous series compensator (SSSC) in Newton power flow," IEEE Trans. Power Syst., vol. 18, no. 4, pp. 1410-1416, Nov. 2003.

[24] A. H. Norouzi and A. M. Sharaf, "An auxiliary regulator for the SSSC transient enhancement", in Proc. IEEE 35th North Amer. Power Symp., Rolla, MO, Oct. 2003.

[25] A. H. Norouzi and A. M. Sharaf, "Two control schemes to enhance the dynamic performance of the STATCOM and SSSC", IEEE Trans. Power Del., vol. 20, no. 1, pp.435-442, Jan. 2005.

[26] M. S. El-Moursi and A. M. Sharaf, "Novel Controllers

- for the 48-Pulse VSC STATCOM and SSSC for Voltage Regulation and Reactive Power Compensation”, IEEE Transactions on Power Systems, vol.20,no.4,November 2005.
- [27] N. Magaji and M.W. Mustafa, “Optimal Thyristor Control Series Capacitor Neuro-Controller for Damping Oscillations”, Journal of Computer Science, Vol.5, No.12, 2009, pp. 983-990.
- [28] K.R. Padiyar, S. Krishna and NageshPrabhu, “On-line detection of loss of synchronism in large power systems”, Int. Conf. on Power Systems, Katmandu, Nepal, November 2004.
- [29] S.S. Choi, B.H. Li and D.M. Vilathgamuwa, “Dynamic voltage restoration with minimum energy injection”, IEEE Trans., Power Systems, v.15, n.1, 2000, pp. 51-57.
- [30] A.K.S.N. Polisetty, “Application of custom power devices for improving power quality”, M.E. Project Report, Indian Institute of Science, July 2005.