

# Servo Controlled EyeBall

Abhishek Mukesh Prasad<sup>1</sup>, Rochelle D'lima<sup>2</sup>

<sup>1,2</sup>Information Technology Department, Thakur Polytechnic

**Abstract:** *With the view of improvising human control over robots and other automated machines, a number of techniques have been devised. The aim is to make these machines more and more human friendly. This has led to technologies, which allow us to simply talk to the robot or make them follow a particular gesture instead of writing extensive codes in difficult computer languages. One such technology, which has a vast scope and thus gaining popularity, is the Object Tracking technique. It involves detecting movement of object through the robot camera and follows the movement. In this project we have designed a Servo controlled Eyeball which is programmed on Raspberry Pi and eye action is controlled by servo motors. A Pi camera is used to capture the movement of object and tracking it using image processing.*

**Keywords:** Buzzer, Pi, Servo, Temperature

## 1. Introduction

Automatic human detection and tracking is an important and challenging field of research and is having many applications in it. Increasing use of computer vision in surveillance, replacing computers in place of human beings has initiated the research in the field of object counting and face detection. Early research mostly concentrated on Human recognition rather than Tracking. Monitoring movements are of high interest in determining the activities of a person and knowing the intentions of the subject. Monitoring the movements of human being has raised the need for tracking. Real-time people flow estimation can be very useful information for several applications like security or people management such as pedestrian traffic management or tourists flow estimation. The use of video cameras to track and count people increase considerably in the past few years due to the advancement of image processing algorithms and computers technology. New creative innovation rotates around how much an item is fit for executing alongside its cost. Many motion detection techniques are extensively investigated in the literature. However, background subtraction techniques are mostly used when dealing with fixed cameras. Each application that benefit from smart video processing has different needs, thus requires different treatment. However, they have something in common: moving objects.

Eyeball tracking is a technique in which the movements of a person or objects are recorded continuously so that the controller knows where a person or objects are moving from one location to another. Eye movements may also be recorded and used in the form of control signals to enable people to interact with robots or other automated devices directly without the need for mouse or keyboard input. This can be a major advantage for certain users for monitoring and security purpose.

The idea behind using eye movement as a control mechanism comes from the fact that eyes are the most extensively used sense organs. Even in disabled or paralyzed people, the eyes are mostly functional and can be effectively used in security devices. It is a human tendency as well as reflex to first look at the object of interest. Thus making use

of this tendency directly can reduce the time required to convey the same to a robot.

## 2. Proposed System

Kriti Bhattacharjee et.al., in this paper presented a technique to control a 3R robot with 3 degrees of freedom (rotational) using the eye movement of the user captured by a USB camera. The x and y coordinates of the iris and pupil center have been used as a parameter to measure the gaze position with respect to the stationary camera. The system was tested on 5 candidates of variable age groups ranging from 25 to 60 years. While the algorithm was able to track eye movement in all the candidates, the exact gaze position was detected with an average accuracy of 65%. Also horizontal movement was detected more efficiently than the vertical one [1].

Onkar R. Kirpanet.al. in this paper, concentrated the issue of following of an obscure question in a video stream, where the protest changes appearance much of the time moves all through the camera see. The application they had created was a Desktop Application in that the client gives a summon to catch picture .This picture was put away as goal picture. After that client offers charge to begin the robot which will catch the picture. This recently caught picture will be contrasted and the goal image [2].

Mr. V.Mustafaet.al. proposed this project to track and count the number of people passing in front of a stationary camera using Raspberry Pi is implemented with accurate results. Perhaps the proposed system is an easy and cost effective method for providing Security in many application areas [3].

RupaGurramet.al. have designed a robot on Raspberry Pi using OpenCV, which was used for object detection based on its colour, size and shape. Here only a single object was being detected at a time. The tracking of the object is based on division of the image into virtual grids. The movement of the robot is based on the position of the object in the grid. An arm is incorporated to pick the object once it is stationary. After picking the object, it would be dropped into its respective coloured container which has a predefined position [4].

### 3. Features

- Security activation & deactivation using Face recognition
- After face recognition user can able to select the surveillance area
- Fire detection , when fire is detected send the current temperature value to authorized user through email/online sms / android app
- Theft protection using buzzer
- Motion detection
- Temperature sensor to monitor temperature of surrounding
- Servo motors
- Raspberry pi 3 model B
- pi camera
- Welcome note after login in TTS
- Mechanical structure as per JTS

### 4. Flow of Working of Servo

#### Control Eyeball

- 1) Servo controlled eyeball is a smart surveillance system which uses camera for monitoring and Raspberry pi as a main system
- 2) This project is divided into 2 parts, one is camera movement and Image processing.
- 3) The system will only turn on when an authorised users face is detected. For that we have to capture and store the image of authorised user.
- 4) To activate the security surveillance user has to do face detection first then he can start the surveillance.
- 5) Once face is detected user can select the area he want to monitor for security purpose.
- 6) Camera will be mounted on the tracking mechanism to capture the object image and give live images to raspberry pi to recognise the object location.
- 7) After that raspberry Pi do image processing through openCV to track the object using blob detection.
- 8) Using Blob detection it will find the area of object and it will start tracking that object.
- 9) As we move object , the blob will also move this is a tracking process using image processing.
- 10) Wherever Raspberry Pi will find that object in image, it will send commands to servo motors to move accordingly to the position of object. Through movement of blob motion of object is detected.
- 11) Temperature sensor is used to sense surrounding temperature, if there is sudden rise in temperature due to fire or any other incidence it will give alert to raspberry pi.
- 12) Raspberry Pi can also detect the fire by using image processing as well as using temperature sensor. If fire is detected then Raspberry Pi will send alert signal to authorised user by activating buzzer and sending notification.
- 13) Theft protection is added as if any other person than the authorised one tries to interact with our system then buzzer will activate to alert the user.

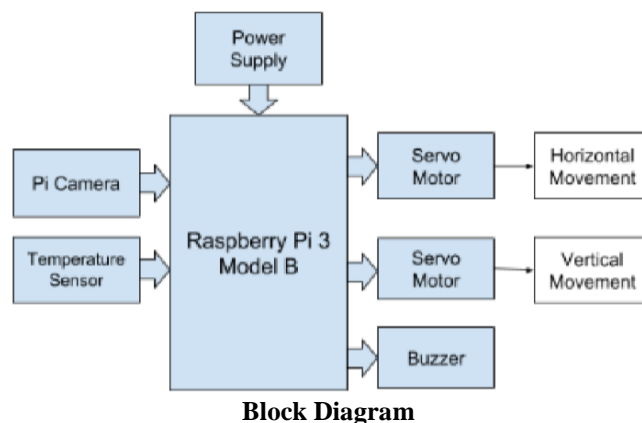

### 5. Hardware Components and Software Used hardware Requirements

- a) Raspberry Pi 3 model B
- b) Arduino Uno Controller-ATmega 328
- c) Wifi Module- ESP8266
- d) Motor Driver-L293D
- e) DC motor- 30 rpm, 12V
- f) CD Display- 20x4 Lcd display
- g) Barcodes on A4 size paper
- h) Limit switch
- i) Android Mobile
- j) Power cable
- k) Desktop / PC
- l) Power Supply

#### Software Requirements

- a) Raspbian OS - OS for rpi
- b) Arduino IDE- Arduino Programming
- c) python for rpi coding
- d) Basics 4 android (B4A) / Android studio for android app.
- e) VNC viewer(not compulsory)

#### Advantages

- a) High security
- b) Human effort is decreased
- c) Easy handling and highly efficient
- d) Accuracy is high.
- e) Less cost

#### Applications

Security purpose - Banks, high security places , military , homes , Games 5.

### 6. Future Scope and Conclusion

- a) Multiple objects can be tracked in single frame. 6.
- b) Wireless communication can be added to notify the authorized person. 7.
- c) The system must supplied with sensors which tell us if someone in place or not. So that camera will on after any motion detection.
- d) Developing the system by adding security system where can recognition between susceptible 8.persons.
- e) In this project, We have designed and developed A servo controlled object tracking eyeball. It will be very useful in surveillance and remote monitoring of a place.

Raspberry pi 3 Model B is used in this development as it is a minicomputer which can perform many important tasks based on 9. On its programming, Pi camera which is connected to Raspberry pi acts as a complete programmable camera system in which image processing is done by using OpenCV.

## References

- [1] Kriti Bhattacharjee, Dr. ManojSoni, "Eye International Journal of Engineering Controlled Robotic Motion Using Video Research & Technology (IJERT). ISSN: Tracking In Real Time". International 2278-0181.Vol. 3 Issue 5, May – 2014.
- [2] Journal of Innovative Research in Science, 11.Krasula, L., Klíma, M., Rogard, E., Engineering and Technology, Vol. 6, Issue Jeanblanc, E. "MATLAB-based 7, 2017. applications for image processing and
- [3] Onkar R. Kirpan , Pooja I. Baviskar , image quality assessment – Part I: Shivani D. Khawase , Anjali S. Mankar , Software description". Radioengineering, Karishma A. Ramteke, "Object Detection 2011, vol. 20, no. 4, p. 1009 – 1015.
- [4] Betke, on Raspberry Pi" International Journal of J. Gips, and P. Fleming, —The camera Engineering Science and Computing, 2017 mouse: Visual tracking of body features to
- [5] Mr. V.Mustafa , Dr. S.A.K Jilani, provide computer access for people with "Raspberry Pi based Real Time People severe disabilities", IEEE Transactions on Detection, Tracking and Counting Neural Systems System", International Journal of Engineering and Techniques - Volume 3 Issue 6, Nov-Dec 2017
- [6] Pradeep Kumar.G.H , RupaGurram, SweathaSuresh.B. , Sneha B. R.,Sushmitha R., "Object Tracking Robot on Raspberry Pi using Opencv",International Journal of Engineering Trends and Technology (IJETT) – Volume 35 Number 4- 2016.
- [7] HarikaNanduri, Dr. ManojSoni, "Vision Controlled Pick And Place of Moving Object By 3R Robot" International Journal Of Advanced Research And Innovative Ideas In Education Vol-2 Issue4, pp.352-358, 2016.
- [8] M R Rajput, G S Sable, "IRIS biometrics survey 2010–2015", Recent Trends in Electronics Information & Communication Technology (RTEICT) IEEE International Conference on, pp. 2028-2033, 2016.
- [9] Ms. RenukaChimurkar, Prof. Vijay Bagdi, Assistant Professor, A.G.P.C.E "Smart Surveillance Security & Monitoring System Using Raspberry PI and PIR Sensor" International Journal of Scientific Engineering and Applied Science (IJSEAS) – Volume-2, Issue-1, 2016.
- [10] Sneha Singh, PradnyaAnap, YogeshBhaigade, J.P. Chavan , "IP Camera. Video Surveillance using Raspberry Pi", International Journal of Advanced Research in Computer and Communication Engineering Vol. 4, Issue 2, 2015.
- [11] Abid Abbasi. "Towards Fast Iris Segmentation for Real-Time Recognition."