

Estimating Social Opinion Dynamics Models from Voting System

Divya¹, Rashmi Mohan², Cynthiya Priyadharshini³

^{1,2}Student, Sri Ramanujar Engineering College, Anna University, Chennai, India

³Assistant Professor, Sri Ramanujar Engineering College, Anna University, Chennai, India

Abstract: *This paper deals with design, build and test a online voting system that facilitates user (the person who is eligible for voting), candidate (Candidate are the users who are going to stand in elections for their respective party), Election Commission Officer (Election Commission Officer who will verify whether registered user and candidates are authentic or not) to participate in online voting. This online voting system is highly secured, and it's design is very simple, ease of use and also reliable. The proposed software is developed and tested to work on Ethernet and allows online voting. It also creates and manages voting and an election detail as all the users must login by user name and password and click on his favorable candidates to register vote. This will increase the voting percentage in India. By applying high security it will reduce false votes.*

Keywords: CSS, HTML, Java Script, JDBC, JSP, MYSQL, ORACLE, Servlet, WAMP

1. Introduction

Voting schemes have evolved from counting hands in early days to systems that include paper, punch card, mechanical lever and optical-scan machines. Electronic voting systems provide some characteristic different from the traditional voting technique, and also it provides improved features of voting system over traditional voting system such as accuracy, convenience, flexibility, privacy, verifiability and mobility. But it suffers from various drawbacks such as Time consuming, Consumes large volume of paper work, No direct role for the higher officials, Damage of machines due to lack of attention, Mass update doesn't allows users to update and edit many item simultaneously. These drawbacks are overcome by Online Voting System. Online Voting System is a voting system by which any Voter can use his/her voting rights from anywhere in the country. We provide a detailed description of the functional and performance characteristics of online voting system. Voter can cast their votes from anywhere in the country without visiting to voting booths, in highly secured way. That makes voting a fearless of violence and that increases the percentage of voting.

1.1 Problem Background

In the recent years there are many literature on online voting has been developed. While online voting has been an active area of research in the recent years, efforts to develop real-world solutions have just begun posing several new challenges.

The use of insecure Internet, well documented cases of incorrect implementations and the resulting security Breaches have been reported recently. These challenges and concerns have to be resolved in order to create public trust in online voting.

1.2 Problem Statement

Online Voting are simple, attractive and ease to use. It

reduces manual efforts and bulk of information can be handled easily. But out of all these features there are some drawbacks with this system are, there can be software failure issue, insecure access of internet and also voter should be familiar with internet.

1.3 Research Objective

The main objective of this study is an important step towards streamlining this effort is to develop a framework and identify necessary properties that a secure and trusted online voting system must satisfy to reduce discovery redundancy. Such a framework will allow us to evaluate as well as compare the merits of existing and future candidate online voting schemes. System should support multi-user environment. System should be fully automated. System should provide concrete security features like creating users and assigning privileges to users of the system. System should be capable to keep track of all the detailed descriptions of the client and the whole details of services offered by the client organization.

Various outputs (reports) should be available online any time. System should be able to handle extremely large volumes of data (i.e. large database support).

1.4 Scope of Study

The scope of the project is that it will use the ID and password created by user to register him/her in the voting site, through this all the details of voter are saved in database. And it will act as the main security to the votes system.

Advanced technology: It is an advanced technology used now a day. It increases the internet knowledge of the users which is very necessary for current generation.

Internet: It is an online facility and hence very useful for the users. Voters can vote from anywhere at any time in India.

E-Mails: Election Commission can send the error report to a

Volume 8 Issue 2, February 2019

www.ijsr.net

Licensed Under Creative Commons Attribution CC BY

particular user if he/she entered false information.

E-SMS: People who have not internet connection they cannot check the emails or not have email they can be informed by SMS on their mobile. Today many websites provide free SMS to the mobile. Election Commission can use these to send any information.

2. Literature Review

2.1 Background

This software is being developed for use by everyone with a simple and self explanatory GUI. This is software that can be used by people to vote in an election. All the user must do is login and click on his favorable candidates to register his vote. The development and testing is done on Ethernet. While online voting system has been an active area of research in recent years, the use of insecure Internet, well documented cases of incorrect implementations reported recently. These challenges are to be resolved so that public should cast their vote in secure and convenient way. Proposed online voting system is a voting system by which any Voter can use his/her voting rights from anywhere in country. Online voting system contains:

- a) Voter's information in database.
- b) Voter's Names with ID and password.
- c) Voter's vote in a database.
- d) Calculation of total number of votes. Various operational works proposed in the system are: Recording information of the Voter in database. Checking of information filled by voter.
- e) Discard the false information.
- f) Each information is sent to election commission.

2.2 Product Perspective

The product is an election conducting tool with a simple GUI. The product is developed using Java. Though product is stand-alone. It requires Java Virtual Machine (JVM).

2.3 User Characteristics

Users are considered to be technically novices but expected to be able to use a computer / hand held terminal (HHT) and to click against the favorable candidate on the GUI.

2.4 Product Functions

The product has a server back-end which takes care of authenticating the users and maintaining necessary data structures. The GUI at the server's end enables creating the polls on behalf of the client. The users must connect to the server to authenticate their identification against the password and then vote using the GUI at their end.

2.5 Overview of Data Requirements

The internal memory requirement will be constant or linearly dependent on the number of users depending on the provision of changing the vote at a later time. In such a case the actions will be stored in a data structure which will be referred to when needed. The external data about the

candidates (with photographs) and the posts or the poll questions and the answers will be given as input only at the server end.

2.6 Assumptions and Dependencies

The user is assumed to have JVM on his system irrespective of its hardware and software configuration. The other requirements are strongly design based and can be only made concrete in the design stage. We also assume that all the clients running this software are not blocked by firewalls, proxies, etc.

2.7 Constraints

GUI is only in English.
Login and password is used for identification of Voter.

3. Salient Feature

On-line polling is software system through which a voter can give votes through registering themselves on the voting website. all the information in sites which has been entered are stored in database .for each page in the website have its own database table.

Each voter has to enter his all basic information like name, sex, religion, nationality, criminal record e.t.c. This is the first page of the website known as the welcome page. It has all the page options like Home, Polling Dates, Register, Login, about us, Contact us, FAQs.

3.1 Home

It is the welcome page of the website, having all the feature options of the website.

3.2 Registration

This is the register page, where the voter, candidate and election commission officer can register themselves. They all have to enter basic information best of their known .All the information registered in the website are saved in the respective database .The Election Commission officer has authority to accept eligible user and suitable candidate, otherwise he/she has right to reject their registration.

3.2 System architecture

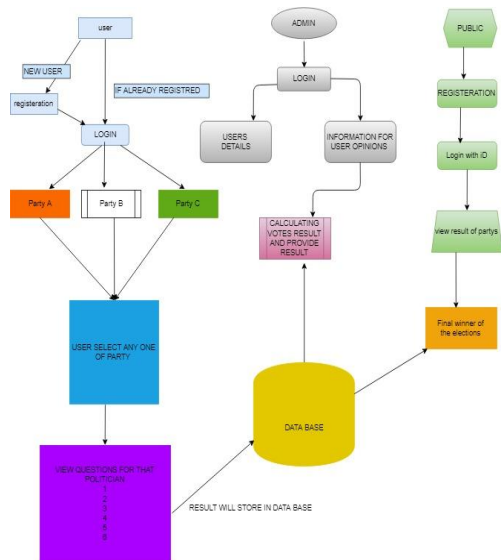

User Login: After registering into the website, this information is saved to the database and sent to the election commission. The user can Login to the website with his unique and PASSWORD generated through registration. There is a option for FORGOT PASSWORD, in case user forget his password then he/she can go with option of forgot password.

Candidate Login: After registration candidate can see his/her profile and can edit his/her profile. The candidate has facilitated with all the latest news update regarding election.

Election commission officer login: After login election commission officer will verify whether user and candidate is authentic or not.

4. Resources

We create this software application with following resources
 Front end - JAVA (JSP,Servlet,JDBC,java mail,EJB2.0)
 Back end - ORACLE/MYSQL
 Design- HTML
 CSS- Cascading Style Sheet
 Validation- JavaScript
 Platform- J2EE

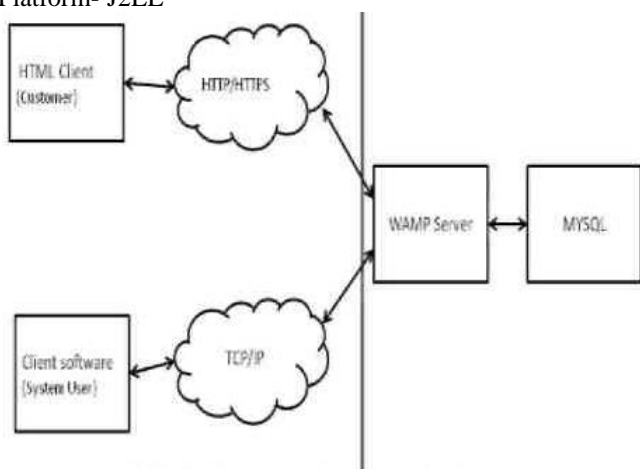

Fig 6: Communication Interfaces

The above diagram shows the connectivity between the client side, application server and database server. The client or customer can access the HTML server or client software. These are connected to the WAMP Server (WAMP) by a

TCP/IP which is a communication protocol used to connect the teachers or parents to the internet. This WAMP Server now directly communicates with the database made in MYSQL. All the enquiries or data will be retrieved from the database.

5. Conclusions

Our proposal enables a voter to cast his/her vote through internet without going to voting booth and additionally registering himself/herself for voting in advance, proxy vote or double voting is not possible, fast to access, highly secure, easy to maintain all information of voting, highly efficient and flexible. Hence, by this voting percentage will increase drastically.

The using of online voting has the capability to reduce or remove unwanted human errors. In addition to its reliability, online voting can handle multiple modalities, and provide better scalability for large elections. Online voting is also an excellent mechanism that does not require geographical proximity of the voters. For example, soldiers abroad can participate in elections by voting online.

References

- [1] Alexander. Stakeholders: Who is your system for? IEEE: Computing and Control Engineering, 14(1):22{26, April 2003}.
- [2] Almyta Systems, Point of Sale Systems. http://systems.almyta.com/Point_of_Sale_Software.asp. Accessed on 20th October 2008.
- [3] S. W. Ambler, Process Patterns: Building Large Scale Systems Using Object Technology, Cambridge University Press, 1998. M. Andrews and J. A. Whittaker, How to Break Web
- [4] Software: Functional and Security Testing of Web Applications and Web Servers. Addison, Wesley, 2006.
- [5] Java-2 Complete Reference - Patrick Haughton
- [6] Java Servlet Programming - O'Reilly
- [7] Pure JavaScript- Jason Gilliam,-R.Allen Wyke
- [8] HTML completes - BPB publications.