

# Performance Evaluation of a Push Type Cassava Harvester

Egbe-Okpenge, I. S<sup>1</sup>, Gbabo, A.<sup>2</sup>

<sup>1</sup>Federal University of Agriculture, Makurdi, Department of Agricultural and Environmental Engineering

<sup>2</sup>Federal University of Technology Minna, Nigeria, Department of Agricultural and Bioresource Engineering

**Abstract:** Cassava harvesting is regarded as the most laborious operation in its production, involving three main sequential operations from stem cutting, soil loosening and then uprooting of the tubers. Relevant properties soil, stem and tuber were determined in evaluating the performance of the cassava harvest. Some of such properties being moisture content were investigated for the soil and stem of cassava in determining the harvesters cutting efficiency, soil loosening and uprooting efficiencies. Soil moisture tests revealed that at harvest, 10 MAP (months after planting), unconditioned (class-C) soil moisture was between 1.5 and 3%, while on conditioning with specific quantities of water (5 – 10 litres), under class A and B treatments, revealed the soils moisture to between 17 – 20% and 10 – 12% respectively. Mean soil moisture content on d.b was evaluated for Class A, B and C treatments as 18.7%, 10.8% and 1.94% respectively. Moisture in the stem was also determined from fifty randomly selected stalk samples and found to be between 45.84 – 81.02%, with a mean of 68.97%. Other properties comprise of mean tuberspread 44.83 cm, mean tuber yield per plant 4.86kg, while average root tuber depth was 16.59 cm. Diameter of stems ranged from 2.08 cm – 4.31 cm with an average of 2.82 cm. Mean cutting efficiency was 48.72%. Optimisation design revealed optimum cutting efficiency as 97.664%, at a moisture content of 70 – 85%, lever arm length of 65 cm, region of cut above ground surface 30 cm and at 4 cutting attempts. Soil loosening efficiency ranged from 52.22 – 100%, with a mean efficiency of 82.952%. Optimisation analysis revealed an optimum soil loosening efficiency for LED and LET as 96.31% and 93.74% at soil moisture of 17 – 20%, lever arm length of 100 cm and loosened depth of 3 cm respectively. Uprooting efficiency ranged from 63.03 – 100% with a mean uprooting efficiency of 77.706%. Optimum uprooting efficiency was 96.678%, observed at the highest soil moisture range of 17-20% and at a lever length of 105 cm. ANOVA test results revealed the effect of moisture content on the stems cutting efficiency, soil loosening efficiency and uprooting efficiency of the harvester, significant at  $p < 0.05$ . Significant effect of number of cutting attempts was observed for the cutting efficiency and length of lever arm for the uprooting efficiency. Field capacity for uprooting operation alone was evaluated as 27.77 man-h ha<sup>-1</sup>, while for the combined operations of stem cutting, soil loosening and uprooting, it was found to be 86.81 man-h ha<sup>-1</sup>.

**Keywords:** Performance, Evaluation, Push-Type, Cassava, Harvester

## 1. Introduction

Cassava, *Manihotesculanta* (Crantz) is a tropical, herbaceous, perennial woody shrub, with a tuberous starchy root of the family Euphorbiaceae [4]. It is an essential source of food and income and classed as one of the three world's most important food crops, amongst rice and maize [11]. Cassava is ranked as the fourth supplier of dietary energy in the tropics (after rice, sugar and maize) and the ninth globally. Its cultivation and processing provide household food security, income and employment opportunities for hundreds of millions of people across the globe, mostly in Africa, Asia and the America. Worldwide, cassava provides the livelihood for more than 500 million farmers and traders [10]. It is a basic staple food for millions of people in the tropical and subtropical regions, as well as being a major source of raw material such as flour and starch for numerous industrial applications and animal food [7],[10].

Nigerians domestic yearly demand for ethanol estimated at 180 million litres was met through importation in 2005 from cassava [15]. The Federal Government of Nigeria recent directive on the substitution of 10% of wheat flour with cassava flour by flour millers, has further led to the surge in demand of cassava produce from between 200,000 and 300,000 tonnes to the tune of 600,000 tonnes per day [19]. All these facts points to opportunities that abound in the area of cassava processing, but, these opportunities cannot be fully exploited using the traditional harvesting and processing methods currently in use in the country which is

generally adjudged as arduous, labour intensive, time consuming and unsuitable for large scale production [1], [22], [3].

Lack of access to mechanised and improved farming systems to support production and processing of cassava is impeding the development of the cassava market in Nigeria. This technological gap has left farmers with little or no option but to produce cassava on a low scale, mainly for subsistence and local markets which is archaic, arduous, mundane and highly labour intensive. Although the continent and Nigeria in particular is ranked the highest producer of cassava in the world, in terms of classification of its yield, it is ranked below the fiftieth (50<sup>th</sup>) position, leaving much to be desired beyond its production status [16]. These and more therefore buttresses the objective of this work; to evaluate the performance of the developed push-type cassava harvester and recommend optimum operational conditions for the machine, as well as recommendations for further improvements.

### 1.1 Performance of Existing Cassava Harvesters

Cassava is basically harvested by cutting off the stalks 20 – 30 cm above the ground (coppicing), using the remaining stump to pull-out the tubers. This is done traditionally with the hands and some traditional implements as a hoe and cutlass. Where the soil is hard, especially during peak dry season, the roots are lifted out of the ground manually using a pointed metal bar or metal fork attached to a wooden stick

used as a lever. A major challenge with this method is the difficulty, drudgery, and tuber damage associated with this harvesting method [8]. Manual cassava harvesting labour requirements as opined by [5] range from 11.1 – 31.9 man-days/ha, comparable with assertions by [16] of 22 – 63 man-days/ha. While [6] investigated the performance of some improved manual cassava harvesters and reported their field capacities at different planting orientations and cassava varieties to range from 52.2 – 121.8 man-h ha<sup>-1</sup>, attributing high uprooting force requirements and yield per plant as factors responsible for higher field capacities (Table 1). Comparing capacities obtained for mechanical and manual harvesting methods, it was generally deduced that, manual cassava harvesting requires longer periods of time than mechanical harvesting, but characterised by lower tuber damage [5].

**Table 1:** Summary of Field Capacity, Tuber Damage and Yield per Plant of the Push-Type Cassava Harvester and other Existing Harvesters

Cassava Harvesters	Field Capacity (man-h/ha)	Tuber Damage (%)	Yield /Plant (kg)
1) Push-Type Harvester	27.77 – 45.14	6.60 – 35.5	2.5 – 9.0
2) CRI Cassava Uplifter (Amponsah et al., 2017)	49.9 – 156	4.32 – 19.55	1.0 – 5.0
3) NCAM Cassava Uplifter (Amponsah et al., 2014)	20.64 – 38.50	–	1.0 – 3.0
4) IITA Cassava Uprooting Device	22.71 – 47.20	–	1.0 – 4.0
5) CTCRI Cassava Uplifter (Amponsah et al., 2014)	26.0 – 40.0	5.83 – 22.00	1.0 – 4.0
6) Prototype Harvester in India	45.72 – 40.28	2.65 – 16.19	–
7) Manual Harvesting (Nweke et al., (2002)	176 – 496	2.13 – 10.50	1.0 – 5.0

Semi-mechanised system of harvesting is an improvement and modification of manual harvesting, which seeks to reduce the drudgery and tuber damage normally associated with manual harvesting. In the semi-mechanised system of cassava harvesting, simple machines, mechanisms or equipment are developed, taking into consideration physical, agronomic and ergonomic principles to simplify the harvesting process. Some improvements have been made by the Central Tuber Crops Research Institute (CTCRI), International Institute for Tropical Agriculture (IITA) and the National Centre for Agricultural mechanization (NCAM), from the traditional harvesting system. The CTCRI Lever, IITA Cassava Lifter and the NCAM Tuber Lifter are all equipped with gripping jaws, to grasp the stalk at the base and a lever to aid for uprooting the tubers. Performance tests for these implements shows harvests of up to 200 plants per man-hour and are classified as semi-mechanised cassava harvesters, since they require some degree of human effort to be used effectively for harvesting [20].

Studies by [5] revealed that, root tuber damage for some TEK mechanical harvesters (MCK's) on different study sites ranged from 7.70 – 26.8%. Generally, field capacity for different TEK MCH's, on three (3) study sites ranged from

1.55 h/ha – 2.96 h/ha. [9] reported a range of 2.63 – 4.0 h/ha for the Leipzig mechanical harvester. Ospino et al., (2007) also, reported a mean field capacity range of 1.0 – 1.6 h/ha for the CLAYUCA Cassava Harvester Model P600 while Oni (2005) reported a range of 0.83 – 1.25 h/ha for the NCAM harvester.

Research shows that most cassava harvesters reported in literature [13], [17], [18] were based on the elevator digger principle whereby the soil engaging component cuts through the soil 0.3 - 0.4 m deep and 0.7 – 0.8 m wide, handling about 50 kg of soil to harvest a single plant” [2]. These kinds of operation necessitates high fuel consumption, characterised by high power requirement and higher tendency of wear and tear to component/machine, in attempt to overcome all the forces acting on the soil when harvesting, especially if the implement is designed to be dragged continuously through the soil.

## 2. Methodology

### 2.1 Machine Description and Components

The machine consists of three mechanisms for soil loosening, stem cutting and tuber harvesting. All three mechanisms were fastened to the frame by means of temporal fasteners (Bolts and nuts). This was necessary for ease of transport and maintenance. The mechanism of a simple machine as the lever was employed in driving and powering all mechanisms of the machine. In the design of the cassava harvester, just the first and second class lever principles were applied. The first class principle of levers having the fulcrum in between the load and the effort was applied in the design and fabrication of the uprooting mechanism, the scraper and secateurs. While the second class lever principle was adopted in driving the machine, with the load in between the effort and the fulcrum. The major components of the harvester are; the machine frame, the wheels, pruning shears (secateurs), lever controls, gripping jaw, soil loosening component (scraper) and the harvester cab (Figure 1).

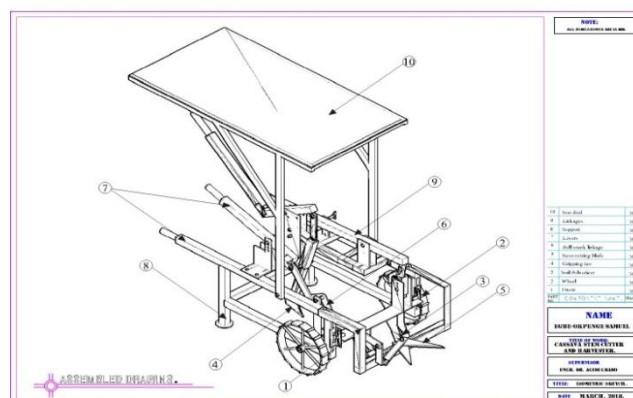

**Figure 1:** Push-Type Cassava Harvester

### 2.2 Preliminary Investigations

The following Preliminary investigation was conducted on relevant physical properties of the soil, cassava stem and tuber, essential in the design of the component parts of the harvester:

### 1) Moisture Content

Moisture content was determined for both the soil and the cassava stem. The soils moisture content was investigated in order to design an experiment to evaluate the machines performance for soil loosening and tuber uprooting, on varying moisture levels and recommend the soils moisture content in which the machine will perform optimally during harvesting. The soils moisture content was determined and classified by randomly collecting nine (9) different soil samples from the cassava field. The classification was based on three treatments; Class A – Ten litres of water applied to the soil, Class B – Application of five litres of water and Class C – No water added.

In order to minimise the possibility of errors, three replicates of soil sample were randomly collected for all three treatments at depths of 0 – 10, 10 – 20 and 20 – 30 cm using a soil sampler and a mallet [23]. Samples were collected for treatments A and B about 15 minutes after the water was added and stored in labelled polythene bags. This was to allow for better absorption of the water by the soil and for easy identification respectively. Treatment C was used as a control system, where no water was added to the soil. Collected soil samples were oven dried at a temperature of 150° for 8 hours, after which were re-weighed and recorded. The soil moisture content was determined for all three treatments using equation 1 [23].

Moisture content in the stem was determined as a variable to investigate the effects of varying moisture levels in the stem to its cutting efficiency. Moisture content in the stem was determined by randomly collecting stem samples of length 15cm from fifty (50) cassava stands from the demonstration farm, cultivated from the TME 419 variety. Each stalk sample was numbered and weighed on a digital lab scale before oven dried at a temperature of 150° for 18hrs. Dry stalk samples were then carefully collected, re-weighed and recorded and the moisture determined. Equation 2 was used to determine the moisture content in the stem. On successful determination of the moisture content in the stems, samples were then classified into three moisture content categories of 40 – 55% (stalks affected by fire from indiscriminate bush burning), 55 – 70% and 70 – 85%.

$$MC_{(d.b)} \% = \frac{W_2 - W_3}{W_3 - W_1} \times 100 \quad (1)$$

$$MC_{(d.b)} \% = \frac{W_w - W_d}{W_w} \times 100 \quad (2)$$

Where,

MC<sub>(d.b)</sub> % = Percentage Moisture content in dry basis

W<sub>1</sub> = weight of sampling bag

W<sub>2</sub> = weight of sampling bag and soil

W<sub>3</sub> = weight of sampling bag and oven dried soil

W<sub>w</sub> = weight of wet stalk

W<sub>d</sub> = weight of oven dried stalk

### 2) Stem Girth/Diameter

This was determined from Fifty (50) randomly selected stem samples from the field, by measuring and recording diameters of each sample, using a Vernier calliper. The mean stem diameter was also calculated and recorded.

### 3) Root Yield per Plant

The root yield is achieved by individually quantifying the mass of each harvested cassava tuber, using a weighing scale

### 4) Root Spread (cm)

This is the horizontal distance between the ends of the tubers along the horizontal, from one end to the other, determined with the aid of a measuring tape.

## 2.3 Experimental Design

A designed experiment was used to simplify the experimental procedure and to provide better understanding of the effects of different variables and factors on the performance of the machine, taking into consideration a number of dependent and independent variables of interest. Data gotten from the field experiments conducted to determine the efficiency of the machine was based on a three variable experimental design, using Design Expert 10.0.1 software.

Experimental design for the cutting efficiency was based on four factors (stem moisture content, length of lever arm, distance of cut above the ground and number of cutting attempts), set at three levels and one (1) response while that for soil loosening efficiency, three factors (soil moisture content, length of lever arm depth), three treatments and two responses, while the uprooting efficiency had just two factors (soil moisture content and length of lever arm), three treatments and one response. The data was subjected to Analysis of Variance (ANOVA) and optimised, using Design expert software.

D – Optimal factorial design was used for optimizing the factors and response for cutting efficiency. Choice of this experimental design was based on the fact that all levels (treatments) of the factors were not the same.

## 3. Results and Discussion

### 3.1 Results of Preliminary investigation

The results of soil moisture for the three class (A, B and C) as shown in Table 2, was the basis for selecting the moisture content range used for each treatment in evaluating the machines soil loosening and uprooting efficiencies. Class A soil sample which was conditioned by addition of 10 litres of water had a mean moisture content of 18.17%, Class B, conditioned by the addition of 5 litres of water had a mean moisture of 10.80% and Class 'C' was unconditioned (no water added) had a mean moisture of 1.94%.

Results of stem diameter and moisture content (d.b), tuber depth, yield per plant and root spread for fifty (50) randomly selected cassava stalk samples is shown in Table 3. It shows that, cassava variety of 10 MAP, had stalk girth of between 2.08 and 4.31 cm with moisture content range of 45.84% - 81.02%, in congruence with findings by [12]. This informed the choice of the range for moisture content in evaluating the machines stem cutting efficiency.

**Table 2:** Summary of Results for Soil Moisture Content

Class	Replicates			Mean
	Sample 1 (%)	Sample 2 (%)	Sample 3 (%)	
A	16.9	18.4	19.2	18.17
B	10.5	11.8	10.1	10.80
C	1.5	1.87	2.45	1.94

**Table 3:** Summary of Results for Preliminary Investigation of Cassava Physical Properties

Properties	Sample Size	Minimum	Maximum	Mean
Stem Diameter (mm)	50	2.08	4.31	2.82
Moisture Content (%)	50	45.84	81.02	68.97
Tuber Depth (cm)	50	10.82	29.48	16.59
Yield per Plant (kg)	50	2.19	8.93	4.86
Root Spread (cm)	50	21.38	69.55	44.83

**3.2 Evaluation of the Machines Performance**

The following performance parameters were used to evaluate the efficiency of the machine for each mechanism:

**3.2.1 Cutting Efficiency ( $P_e$ ):**

An experimental design, based on all likely significant factors, with regards to literature was used in collecting and recording data from the field.

Factor 1 – Moisture content had 3levels (40 – 55, 55 – 70 and 70 – 85%).

Factor 2 – Length of lever arm from fulcrum had 3levels (60, 65 and 70 cm).

Factor 3 – Distance of Cut above ground level had 3levels (20, 30, and 40 cm).

Factor 4 – Number of cutting attempts had 5levels (1, 2, 3, 4, and 5).

Equation 3 was used to determine the cutting efficiency. The results obtained from evaluating the cutting efficiency (Table 4) shows that the cutting efficiency ranged from 0 – 100%, while Mean cutting efficiency was evaluated to be 48.72%.

$$P_e = \frac{P_r}{P_r + U_{pr}} \times 100\% \tag{3}$$

Where;  $P_r$  = Number of stalks cut

$U_{pr}$  = Number of Un-cut stalks

**Table 4:** Summary Results for Cutting Efficiency and Optimization Design

Factors Characteristics Before and After Analysis								
Factor Name	Units	Type	Subtype	Minimum	Maximum			
Stem moisture	%	Categorical	Nominal	40 -55	70 - 85	Levels:	3	
Length of lever arm from fulcrum	cm	Categorical	Ordinal	60	70	Levels:	3	
Distance of cut above ground level	cm	Categorical	Ordinal	20	40	Levels:	3	
Number of Cutting Attempts		Categorical	Nominal	1	5	Levels:	5	
Cutting Efficiency Responses Characteristics Before and After Analysis								
Response Name	Units	Observations	Analysis	Minimum	Maximum	Mean	Std. Dev.	Transform
Cutting Efficiency	%	52	Factorial	0	100	48.72	35.83	None

Software Setting for Analysis: File Version –10.0.1.0; Study Type – Factorial; Design Type – D-optimal; Optimization Model – 2 factor interaction (2FI); Subtype – Randomized; Runs – 52; Blocks – No Blocks; Replication – 3.

**Analysis of Variance for Cutting Efficiency (ANOVA)**

The ANOVA table (Table 5) shows that a two factor interaction (2FI) model equation was used to optimize the evaluated values for cutting efficiency. This was because, all insignificant factors were eliminated at  $p < 0.05$ , with exception of just two factors (Stem moisture and Number of cutting attempts), found to be significant at  $p < 0$ . The ANOVA table shows that there was no interaction between

Stem moisture and number of cutting attempts, the two significant factors.

**Optimisation of Cutting Efficiency**

Table 6 shows optimized solutions recommended in using the developed harvester, at a stem moisture of 70 – 85%, length of lever arm from fulcrum 70 cm, distance of cut above ground level 40cm and at 4 cutting attempts, with a cutting efficiency of 97.664%. This was selected because, at a lever arm length of 70 cm and a region of cut of 40 cm above the ground, the cutting lever is observed to have a higher leverage and mechanical advantage than at 60 or 65 cm.

**Table 5:** ANOVA for Evaluation of Cutting Efficiency

Source	Sum of Squares	Df	Mean Square	F Value	p-value Prob>F	
Model	52059	6	8676.5	29.1065	$6 \times 10^{-14}$	significant
Stem Moisture	19599.4	2	9799.71	32.8745	$0.158 \times 10^{-9}$	significant
No. of Attempts	33183.2	4	8295.79	27.8293	$1.157 \times 10^{-11}$	significant
Residual	13414.3	45	298.095			
Cor Total	65473.3	51				

**Table 6:** Optimized Solutions

Number	Stem Moisture (%)	Length of lever arm from fulcrum (cm)*	Distance of cut above ground level (cm)*	Number of Cutting Attempts	Cutting Efficiency (%)	Desirability
1	70 - 85	65	30	4	97.664	0.9766
2	70 - 85	70	20	4	97.664	0.97664
3	70 - 85	60	20	4	97.664	0.97664
4	70 - 85	60	40	4	97.664	0.97664
5	70 - 85	65	20	4	97.664	0.9766

6	70 - 85	65	40	4	97.664	0.9766
7	<b>70 - 85</b>	<b>70</b>	<b>40</b>	<b>4</b>	<b>97.664</b>	<b>0.9766</b>
8	70 - 85	70	30	4	97.664	0.9766
9	70 - 85	60	30	4	97.664	0.9766
10	70 - 85	65	40	3	76.771	0.7677
11	70 - 85	70	20	3	76.771	0.7677
12	70 - 85	70	40	3	76.771	0.7677
13	70 - 85	60	40	3	76.771	0.7677
14	70 - 85	60	20	3	76.7713	0.7677

**3.2.2 Soil Loosening Efficiency (L<sub>e</sub>):**

The soil loosening efficiency was determined by engaging the diggers to loosen the soil at varying depths prior to uprooting. Equation 4 and 5 were used to determine the efficiency of the soil loosening component as shown in summary in table 7.

$$L_{eD} = \frac{D_{Act}}{D_{Prd}} \times 100\% \tag{4}$$

$$L_{eT} = \frac{W_H}{W_H + W_B} \times 100\% \tag{5}$$

Where:

*D<sub>Act</sub>* = Actual depth loosed (cm)

*D<sub>Prd</sub>* = Predicted loosening depth (cm)

*W<sub>H</sub>* = Mass of harvested tuber (kg)

*W<sub>B</sub>* = Mass of Broken/damaged tuber (kg)

*W<sub>H</sub> + W<sub>B</sub>* = Total root yield (kg)

Soil loosening efficiency was evaluated on the bases of actual depth of soil loosed (LED) and on unbroken tuber

uprooted after loosening (LET). Results obtained from evaluating the soil loosening efficiency showed that, Soil Loosening Efficiency with respect to depth (LED) ranged from 52 – 100 %, while Soil Loosening Efficiency with respect to Whole tuber (LET) ranged from 50 – 100 %, with mean loosening efficiencies of 82.95% for LED and 80.08% for LET. Low levels of LED and LET were linked to the inability of the diggers to loosen the soil to the required depth, especially at lower soil moisture levels and obstruction from tubers in the soil, necessitating more cushion to minimize tuber damage.

Higher efficiencies were observed on soils with higher moisture contents and shallow rooted tubers. A reduction in tuber damage and higher mean loosening efficiency, in comparison to mean uprooting efficiency was also observed, when soil loosening was first employed before uprooting tubers. This is in congruence with assertions by [23], [2], [6].

**Table 7: Design Summary for Soil Loosening Efficiency**

Factors Characteristics Before and After Analysis									
Factor	Units	Type	Subtype	Minimum	Maximum				
Soil Moisture	%	Categorical	Nominal	1.5 - 3	17 - 20	Levels:	3		
Length of lever arm from fulcrum	cm	Categorical	Ordinal	90	100	Levels:	3		
Soil loosening depth	cm	Categorical	Ordinal	3	9	Levels:	3		
Responses Characteristics Before and After Analysis									
Response	Units	Obs	Analysis	Minimum	Maximum	Mean	Std. Dev.	Trans	Model
Soil Loosening Efficiency with respect to depth (LED)	%	24	Factorial	52.2	100	82.952	15.66063	None	Linear
Soil Loosening Efficiency with respect to Whole tuber (LET)	%	14	Factorial	50.3	100	80.081	14.57792	None	Linear

**Analysis of Variance for Soil Loosening Efficiency (ANOVA)**

The ANOVA in table 8 shows that, the linear model equation used to optimize the results of soil loosening efficiency with respect to depth (LED) and with respect to Whole tuber (LET) were significant. This was because; insignificant factors at *p* < 0.05 were eliminated. Soil loosening depth and Soil moisture were the only significant factors (at *p* < 0.05) for LED and LET respectively. Increase in the soils moisture level results to decrease in the soils strength and penetration resistance, further leading to ease of uprooting tubers with less breakage, as opined from soil sampling analysis by [2], [6]. Whereas for soil loosening efficiency with respect to depth (LED), soil moisture was observed to be less significant, as well as length of lever arm due to difficulty of the diggers to loosen the soil to a required depth, principally

as a result of obstructions from the tubers in the soil, observed to lie between depths of 5 – 10 cm below the surface.

**Optimisation of Soil Loosening Efficiency**

Result for optimization of the soil loosening efficiency is shown in Table 9. Constrains were that, the goals of the optimization were to get the best soil loosening efficiencies for LED and LET across the range of soil moistures, length of lever arm from fulcrum and Soil loosening depth. The best optimized solutions was set at Soil moisture (17 – 20%), length of lever arm from fulcrum (100 cm), Soil loosening depth (3cm), Soil Loosening efficiency on depth (LED) and Soil Loosening efficiency on whole tuber (LET) as 96.31% and 93.74% respectively.

Table 8: ANOVA for Soil Loosening Efficiency

Source	Sum of Squares	Df	Mean Square	F Value	p-value	Prob> F
<i>Soil Loosening Efficiency with respect to depth (LED)</i>						
Model	3568.393	2	1784.196	18.079	2.717 x 10 <sup>-5</sup>	significant
Soil loosening depth (cm)	3568.393	2	1784.196	18.079	2.717 x 10 <sup>-5</sup>	significant
Residual	2072.482	21	98.689			
Cor Total	5640.874	23				
<i>Soil Loosening Efficiency with respect to Whole tuber (LET)</i>						
Model	2404.693	2	1202.347	10.168	0.000816	significant
Soil moisture (%)	2404.693	2	1202.347	10.168	0.000816	significant
Residual	2483.167	21	118.246			
Cor Total	4887.86	23				

Software Setting for Analysis: File Version –10.0.1.0; Study Type – Factorial; Design Type – D-optimal; Optimization Model – linear; Subtype – Randomized; Runs – 24; Blocks – No Blocks; Replication – 3

3.2.3 Uprooting Efficiency (Uε)

The uprooting efficiency of the machine was evaluated using equation 3.

$$U_{\epsilon} = \frac{W_{up}}{w_{up} + W_{bk}} \times 100\% \quad (3)$$

Where,

W<sub>up</sub> = Mass of Uprooted Cassava tubers (kg)

W<sub>bk</sub> = Mass of broken tubers dug out of the soil (kg)

Results obtained from evaluating uprooting efficiency shows that the uprooting efficiency ranged from 63 – 100 %. The following factors were attributed responsible for low uprooting efficiencies; low soil moisture at time of harvest, leading to higher cohesion, bulk density and compaction, other factors are, tuber depth and root spread, which lead to root damage as a result of the difficulty in uprooting the tubers, as asserted by [2], [14], [24]. Figure 4 shows the effect of soil moisture content and lever arm length of the uprooting efficiency of the machine.

Table 9: Optimization of Soil Loosening Efficiency

Runs	Soil Moisture (%)	Length of lever arm from fulcrum (cm)	Soil loosening depth (cm)	Soil Loosening Efficiency with respect to depth (LED)	Soil Loosening Efficiency with respect to Whole tuber (LET)	Desirability
1	17 - 20	100	3	96.31	93.737	0.898
2	17 - 20	95	3	96.312	93.737	0.898
3	17 - 20	90	3	96.313	93.737	0.898
4	17 - 20	100	6	85.713	93.737	0.783
5	17 - 20	95	6	85.714	93.737	0.783
6	17 - 20	90	6	85.714	93.737	0.783
7	10 - 12	100	3	96.313	76.486	0.697
8	10 - 12	90	3	96.313	76.486	0.697
9	10 - 12	95	3	96.313	76.486	0.697
10	10 - 12	100	6	96.313	76.486	0.608
11	10 - 12	90	6	96.313	76.486	0.608
12	10 - 12	95	6	96.313	76.486	0.608
13	1.5 - 3	100	3	96.313	70.021	0.605
14	1.5 - 3	95	3	96.313	70.021	0.605
15	1.5 - 3	90	3	96.313	70.021	0.605
16	1.5 - 3	90	6	85.714	70.021	0.527
17	1.5 - 3	100	6	85.714	70.021	0.527
18	1.5 - 3	95	6	85.714	70.021	0.527
19	17 - 20	100	9	66.83	93.736	0.517
20	17 - 20	90	9	66.83	93.737	0.517
21	17 - 20	95	9	66.83	93.737	0.517
22	10 - 12	95	9	66.83	76.487	0.401
23	10 - 12	90	9	66.83	76.487	0.401
24	10 - 12	100	9	66.83	76.487	0.401
25	1.5 - 3	100	9	66.83	70.021	0.348
26	1.5 - 3	90	9	66.83	70.021	0.348
27	1.5 - 3	95	9	66.83	70.021	0.348

Analysis of Variance for Uprooting Efficiency (ANOVA)

A 2 factor interaction (2FI) model equation was used to optimize the evaluated results for uprooting efficiency. Soil moisture and Length of uprooting lever arm from fulcrum

were found significant at p < 0.05 (Table 10). ANOVA results for uprooting efficiency shows that any increase or reduction in the soil moisture or the length of uprooting lever

will have symbolic effects on the quality of tubers harvested by the machine.

**Optimisation of Uprooting Efficiency**

Optimization design summary for the uprooting efficiency is shown in table 11. Constrains were set before optimizing uprooting efficiency. These constrains were that the goals of

the optimization were to get the best uprooting efficiency across the range of soil moisture and length of lever arm from fulcrum, taking into consideration the ease of operating the machine. Table 12 shows the set constrains for optimisation and the optimized solutions generated for all possible combinations to achieve all set goals.

**Table 10: ANOVA for Evaluation of Uprooting Efficiency**

Source	Sum of Squares	Df	Mean Square	F Value	p-value	Prob> F
Model	1801.262	4	450.316	38.824	1.107 x10 <sup>-5</sup> *	significant
Soil moisture	1210.846	2	605.423	52.197	1.118 x10 <sup>-5</sup> *	significant
Uprooting lever arm from fulcrum	250.46	2	125.23	10.797	0.00406*	significant
Residual	104.39	9	11.599			
Lack of Fit	22.637	4	5.658	0.346	0.837	NS
Cor Total	1905.652	13				

(\*Significant at p<0.05: NS – Not Significant)

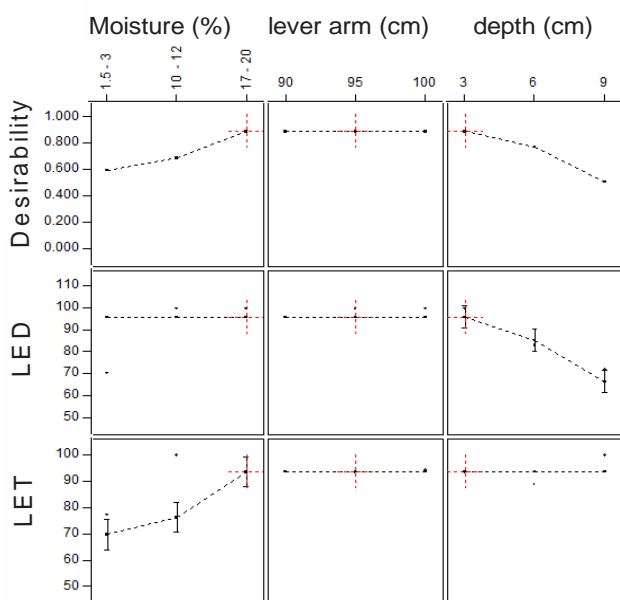

**Figure 3: Effect of Moisture content, Lever arm length and Soil Depth on Soil Loosening Efficiency (LED and LET)**

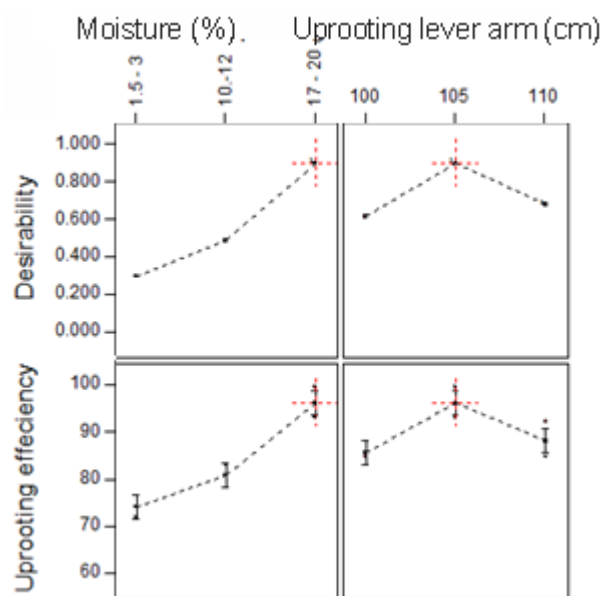

**Figure 4: Effect of Uprooting Efficiency on Moisture and Length of Lever arm**

**3.2.4 Field Capacity (C)**

Field capacity of the machine is expressed as the area of field covered in a given time and it is obtained from equation 4. The machines field capacity for uprooting operation only ranged from 27.77 – 45.14 man-h ha<sup>-1</sup>. While a combined sequence of operations of stem cutting, soil loosening and uprooting, had a capacity of between 86.81 – 149.79 man-h ha<sup>-1</sup>

$$C = \frac{10000 \times t}{A \times 3600} \tag{4}$$

Where;

C = Field capacity (hectares/hour)

t = total time recorded during harvest (seconds)

A = Area harvested (m<sup>2</sup>)

**Table 11: Optimization Design Summary for Uprooting Efficiency**

Factor Characteristics Before and After Analysis									
Factor	Units	Type	Subtype	Minimum	Maximum				
Soil Moisture	%	Categorical	Nominal	1.5 - 3	17 - 20	Levels: 3			
Length of Uprooting Lever	cm	Categorical	Ordinal	100	110	Levels: 3			
Responses Characteristics Before and After Analysis									
Response	Units	Obs	Analysis	Minimum	Maximum	Mean	Std. Dev.	Trans	Model
Uprooting Efficiency	%	14	Factorial	63.03	100	77.706	12.107	None	2FI

**Table 12:** Optimization of Cutting Efficiency

Number	Soil moisture (%)	Uprooting lever arm from fulcrum (cm)	Uprooting Efficiency	Desirability	
1	17 - 20	105	96.678	0.91	<i>Selected</i>
2	17 - 20	110	88.534	0.689	
3	17 - 20	100	86.135	0.625	
4	10.-12	105	81.383	0.5	
5	1.5 - 3	105	74.481	0.31	
6	10.-12	110	73.238	0.276	
7	10.-12	100	70.839	0.211	
8	1.5 - 3	110	66.337	0.089	
9	1.5 - 3	100	63.938	0.025	

## 2. Conclusion and Recommendations

Mean stem cutting efficiency was 48.72%. Optimum cutting efficiency was 97.664%. ANOVA test showed that stem moisture content and cutting attempts were significant in the cutting efficiency of the machine. Soil loosening mechanism was evaluated on two criteria; on the bases of actual depth of soil loosed (LED) and on unbroken tuber uprooted (LET), with respect to depth loosed. Soil loosening efficiency ranged from 50 – 100%, with a mean efficiency of 82.95% and 80.1% for LED and LET respectively. ANOVA results revealed soil loosening depth and soil moisture content as significant factors for LED and LET. Optimum soil loosening efficiency for LED and LET were 96.31% and 93.74%. Uprooting efficiency ranged from 63.03 – 100%, with a mean of 77.706%. Optimum uprooting efficiency was 96.678% at soil moisture of 17-20% and at a lever length of 105 cm. ANOVA showed that both factors were significant. Field capacity for uprooting operation alone was evaluated as 27.77 man-h ha<sup>-1</sup>, while for the combined operations of stem cutting, soil loosening and uprooting, it was found to be 86.81 man-h ha<sup>-1</sup>.

The following recommendations to aid improvements on the design, performance and ease of operation of the machine were drawn;

- 1) Reduction in weight of the entire machine to further conserve energy required in manoeuvring and driving the machine.
- 2) The drive wheels diameter be increased to ease movement and improve traction of the machine in the field, enabling harvesting on both ridge and on mounds and also to accommodate a wider range of ridge heights during harvesting.
- 3) Thickness and length of the cutting blade be increased to further ease coppicing and reduce the number of cutting attempts, irrespective of the stem girth and moisture.
- 4) The soil loosening component diggers should be adjusted to minimise bruises and damage to tubers and for ease of disengaging on completion of its operation.
- 5) Subsequent adoption of a design to allow for the machine being driven by an engine and the mechanisms control by a hydraulic system will further ease operation and increase timeliness.

## References

- [1] Adetan, D. A, Adekoya L. O and Aluko, O. L. Characterization of some properties of cassava root tubers. *Journal of Food Engineering*. 59: 349-353, 2003.
- [2] Agbetoye, L. A. S., Dyson, J. and Kilgour, J. Prediction of the Lifting forces for cassava Harvesting. *Journal of Agricultural Engineering Research*. Vol. 75, Issue 1. January 2000. Pg. 39 -48, 2000.
- [3] Agbetoye L. A. S. Improving the technology of cassava harvesting and processing mechanization for food security in Nigeria. Paper presented at the International Conference on Science and Technology, Held at the Federal University of Technology, Akure, Ondo State, Nigeria. pp 196 – 204, 2005.
- [4] Akinwonmi, A.S. and Andoh, F. Design of a Cassava Uprooting Device. Department of Mechanical Engineering, University of Mines and Technology, Tarkwa, Ghana. *Research Journal of Applied Sciences, Engineering and Technology* 5(2): pp. 411-420, 2013.
- [5] Amponsah, S. K., Bobobee, E. Y. H., Agyare, W. A., Okyere, J. B., Aveyire, J., King, S. R, and Sarkodie-Addo, J. Mechanical Cassava Harvesting as influenced by Seedbed Preparation and Cassava Variety. *Applied Engineering in Agriculture*. Vol. 30(3): 391-403, 2014.
- [6] Amponsah, S. K., Berchie, J. N., Manu-Aduening, J., Eric, O. D., Jonas OseiAdu, Adelaide Agyeman and Enoch B. (2017). Performance of an Improved Manual Cassava Harvesting Tool as influenced by Planting Position and Cassava Variety. *African Journal of Agricultural Research*. 12(5), 309 – 319.
- [7] Anderson, J.V., Delseny, M., Fregene, M. A., Jorge, V., Mba, C., Lopez, C., Restrepo, S., Soto, M., Piegu, B., Verdier, V., Cooke, R., Tohme, J. and Horvath, D. P. (2004). An EST Resource for Cassava and other Species of Euphorbiaceae. *Plant Molecular Biology* 56: 527–539, Kluwer Academic Publishers, Netherlands.
- [8] Bobobee, E. Y. H. Methodology for Mechanised Cassava Production: The Ghanaian and South African Experience. Agricultural Research Council-Institute for Agricultural Engineering, Pretoria, South Africa. 2014.
- [9] Bobobee, E. Y. H., Okyere, J. B., Twum, A., Neumann, R. H., & Knechtges, H. (1994). Performance evaluation of a mechanical cassava harvester. *Proc. Intl. Commission of Agric. Eng. (CIGR) XII World Congress, Ag. Eng' 94, Milano 94*. Report No. 94-D-066. Italy.
- [10] FAO and IFAD (2001). Strategic Environmental Assessment-An assessment of the Impact of Cassava Production and Processing on the Environment and Biodiversity. Proceeding of the Validation Forum on the Global Cassava Development *Strategy. Volume 5*. Rome, Italy.
- [11] IFAD, A.U and NEPAD (2008). Working together to enable smallholders to influence rural development policies in Africa. Rome, Italy: IFAD. Retrieved from <http://www.ifad.org/pub/factsheet/nepad/nepad.pdf>.
- [12] Kaewwinud, N., Khokhajaikiat, P. and Boonma, A. (2017). Effect of Moisture and Region of Cut on Cassava Stalk Properties in Biomass Application. *Res. Agr. Eng.*, 63, 23 – 28.
- [13] Kemp, D.C. (1978). Harvesting: A demonstration of two machines—Cassava harvesting and processing. In



*Proceedings of a Workshop Held in CIAT, Cali, Colombia, 24–28 April 1978.*

- [14] Kolawole, P. O., Agbetoye, I. and Ogunlowo, S. A. (2010). Sustaining World Food Security with Improved Cassava Processing Technology: The Nigeria Experience. *Sustainability* 2010, 2, 3681-3694, 2010.
- [15] Nigeriafirst, (2011), [www.nigeriafirst.org](http://www.nigeriafirst.org). Accessed in 2012.
- [16] Nweke, F. I., Dunstan S. C. S. and Lynam J. K. (2002). The Cassava Transformation: Africa's Best Kept Secret. *Lansing, Mich., USA: Michigan State University Press.*
- [17] Odigboh, E. U. and Ahmed, S. F. A cassava harvester: design analysis and prototype development. *Agricultural Mechanisation in Asia, Africa and Latin America*, 14(4), Pp. 40 – 48, 1982.
- [18] Odigboh, E. U. A single-row model I Cassava harvester. *Agric. Mech. Asia Afr. Lat. Amer.* 1991, 22, 63-66, 1991.
- [19] Olukunle, O. J. Development of a cassava peeling machine. Abstract Proceedings of the International Conference on Global Food and Product Chain. – Dynamics, Innovations, Conflicts and strategies. 'Tropentag 2005', University of Hohenheim Stuttgart, Germany, pp.54, 2005.
- [20] Oni, F. C and Eneh, M. C. C. (2004). Strategies for reducing the cost of Production and Processing of Cassava, *Paper presented at the facilitation and sensitization workshop for cassava producing States under the Presidential Initiatives on Cassava Production and Export*, 8th – 12th November, 2004. Federal Ministry of Agriculture and Rural Development, Abuja.
- [21] Ospino, B., Cadavid, L. F., Garcia, M. And Alcalde, C. (2007). Mechanisation of Cassava Production in Columbia. *Latin American and Caribbean Consortium to Support Cassava Research and Development (CLAYUCA), CIAT, Apartado Aereo 67-13.*
- [22] Quaye, W., Gayin, J., Yawson, I. and Plahar, W. A. (2009), Characteristics of various cassava processing methods and the adoption requirements in Ghana. *Journal of Root Crops*, vol. 35 No.1, pp. 59-68.
- [23] Smith, D. W., Sims, B. G. and O'Neill, D. H. (1994). Testing and Evaluation of Agricultural Machinery and Equipment: Principles and Practices. Textbook. FAO Agricultural Services Bulletin 110.
- [24] Udensi, E. U., Gbasse, T., Ebere, U. F., Godwin, A., Chuma, E., Benjamin, C. O. Chyka, O., Paul, I., Richardson, O. and Alfred, D. Adoption of Selected Improved Cassava Varieties among Smallholder Farmers in South-Eastern Nigeria. *Journal of Food, Agriculture and Environment*, 9(1), 329-335, 2011.