

A Review on OFDM-IDMA Technique & its Implementation

Payal Sahu¹, Deepti Rai²

¹PG Student ECE Dep't., Alpine Institute of Technology, Ujjain, India

²Associate Professor ECE Dep't., Alpine Institute of Technology, Ujjain, India

Abstract: *It is difficult to analyze the performance of OFDM-CDMA systems. To accomplish this task, we need to characterize the correlation matrix among spreading sequences, because the system performance dependent on the choices of signature sequences. Although the performance is not sensitive to the choices of spreading sequences when long random spreading codes are employed, it is still mathematically demanding to evaluate the performance by large random matrix theory. OFDM-IDMA does not involve signature sequences, which greatly simplifies the problem. This research paper reviews the basic ideas of OFDM-IDMA and several ways in which this concept has been implemented.*

Keywords: OFDM, OFDM-IDMA, frame interleave, fast Fourier transform, wavelet transform

1. Introduction to OFDM

Orthogonal frequency-division multiplexing (OFDM) is a method of encoding digital data on multiple carrier frequencies. OFDM has developed into a popular scheme for wideband digital communication, used in applications such as digital television and audio broadcasting, DSL Internet access, wireless networks, powerline networks, and 4G mobile communications.

OFDM is a frequency-division multiplexing (FDM) scheme used as a digital multi-carrier modulation method. A large number of closely spaced orthogonal sub-carrier signals are used to carry data [1] on several parallel data streams or channels. Each sub-carrier is modulated with a conventional modulation scheme (such as quadrature amplitude modulation or phase-shift keying) at a low symbol rate, maintaining total data rates similar to conventional single-carrier modulation schemes in the same bandwidth.

The primary advantage of OFDM over single-carrier schemes is its ability to cope with severe channel conditions (for example, attenuation of high frequencies in a long copper wire, narrowband interference and frequency-selective fading due to multipath) without complex equalization filters. Channel equalization is simplified because OFDM may be viewed as using many slowly modulated narrowband signals rather than one rapidly modulated wideband signal. The low symbol rate makes the use of a guard interval between symbols affordable, making it possible to eliminate intersymbol interference (ISI) and utilize echoes and time-spreading (on analogue TV these are visible as ghosting and blurring, respectively) to achieve a diversity gain, i.e. a signal-to-noise ratio improvement. This mechanism also facilitates the design of single frequency networks (SFNs), where several adjacent transmitters send the same signal simultaneously at the same frequency, as the

signals from multiple distant transmitters may be combined constructively, rather than interfering as would typically occur in a traditional single-carrier system.

2. Introduction to OFDM-IDMA

In OFDM-CDMA systems, spreading sequences are employed to distinguish signals from different users. From a coding theory point of view, it is not a wise choice to use spreading sequences for user separation, since the spreading operation results in band-width expansion without coding gain. The theoretical analysis in [1], [2] shows that the capacity of multiple access channel can only be approached, when entire bandwidth expansion is devoted to FEC coding. The idea of a hybrid communication scheme combining OFDM and IDMA has recently been proposed and studied in [3] [4]. The OFDM-IDMA scheme, which employs IDMA instead of CDMA in OFDM-CDMA inherits many attractive features of well-studied OFDM-CDMA scheme, such as the simple treatment of ISI and effective mitigation of cross-cell interference. Furthermore, the adoption of IDMA introduces additional benefits. In particular, IDMA allows a simple and effective turbo-type iterative MUD algorithm applicable to system with large number of users, which is crucial for system achieving high throughput. The CBC detection algorithm has linear complexity with the number of users K . Since random interleaves are employed to distinguish signals from different users, the spreading operation can be avoided in the OFDM-IDMA scheme. In this situation, the OFDM-IDMA scheme devotes entire bandwidth expansion to FEC coding and obtains additional coding gain.

The uplink transmitter and receiver structures of OFDM-IDMA with K simultaneous users are shown in Fig below:-

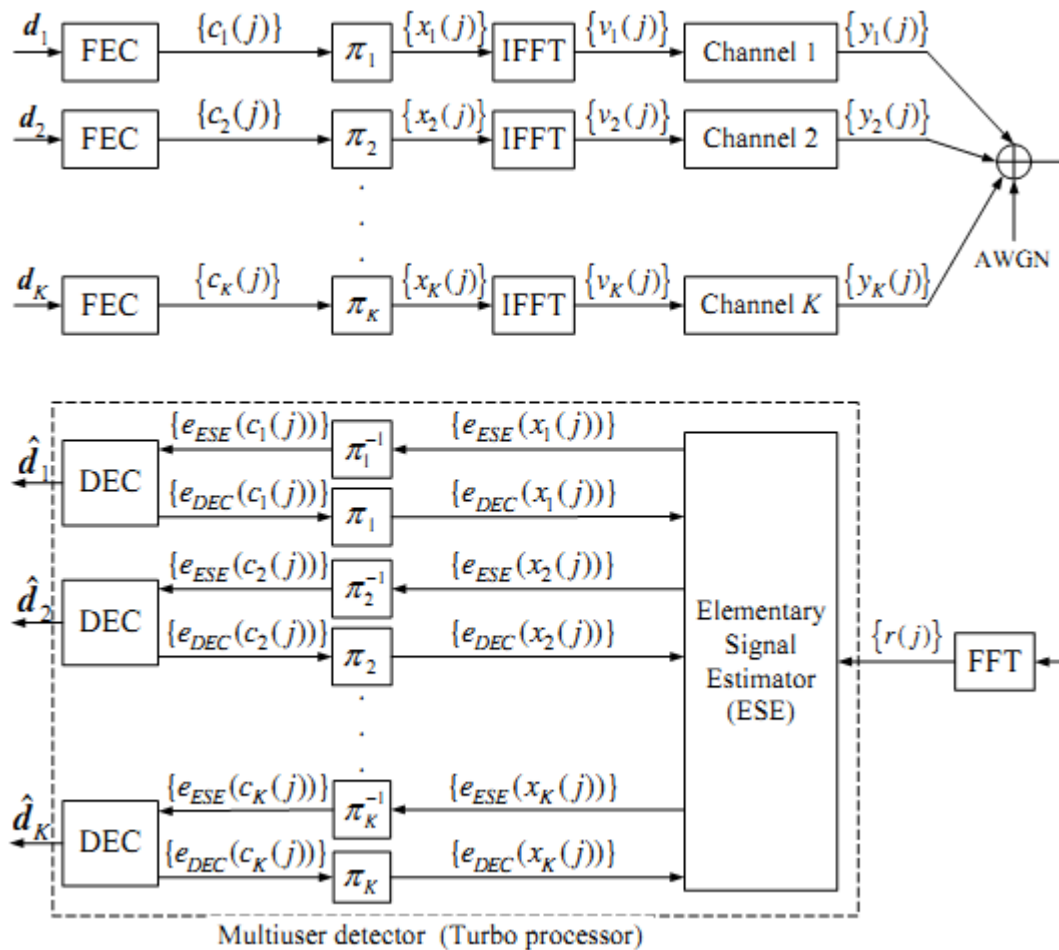

Figure 1: Transmitter and receiver structures of the OFDM-IDMA scheme with K simultaneous users

Let d_k be the data stream of user- k . This data stream is encoded by a forward error correction (FEC) code, generating a chip sequence c_k . (Here, “chip” is used instead of “bit” as the FEC encoding may include spreading or repetition coding.) Then c_k is permuted by a user-specific interleaver- k . After symbol mapping, the symbol sequence $x_k = [x_k(1), \dots, x_k(j), \dots, x_k(J)]^T$ is produced, where J is the frame length. Then these symbols are modulated onto different subcarriers by IFFT.

Consider QPSK signaling :-

$$x_k(j) = x_k^{Re}(j) + ix_k^{Im}(j).$$

After OFDM modulation, the transmitted sequence can be expressed as :-

$$v_k = W^H x_k$$

is divided into blocks with length of N_c for OFDM transmission, where N_c is the number of subcarriers.) W is DFT matrix and the superscript “ H ” indicates Hermite transpose. The (m, n) -th entry of W is

$$W[m, n] = \frac{1}{\sqrt{N_c}} e^{-i2\pi mn/N_c}$$

We assume an L -path channel model with fading coefficients $h_k = [h_k(0); h_k(1); \dots; h_k(L-1)]$ for user- k . The output of multipath channel can be written as :-

$$y = \sum_k y_k + z = \sum_k h_k * v_k + z,$$

where $*$ denotes the convolution and the elements of z are samples of additive noise. At the receiver side, OFDM demodulation is carried out before iterative MUD process as shown in lower half of Fig. 3. Assuming that the duration of cyclic prefix is longer than the maximum channel delay, the received signal after OFDM demodulation can be expressed as:-

$$r(j) = \sum_k H_k(j)x_k(j) + Z(j),$$

Then the CBC detection algorithm for complex single-path channel can be applied [31]. The main difference between the detection process described in Section 2.4 and detection algorithm proposed here is that the fading coefficients of OFDM subcarriers $f H_k(j) g$ are different for different j in a frequency selective channel in the OFDM-IDMA scheme, while in Section 2.4 we consider multipath quasi-static fading channels and the fading coefficients $f h_k(l) g$ are identical for all chips of user- k during one frame. (l is the path index.)

3. Various Implementation Scenarios for OFDM-IDMA

In 2013 Vijay Kumar Kol and Agya Mishra in their research paper titled **Discrete Wavelet Transform based OFDM-IDMA System with AWGN Channel** presented a model which is Discrete Wavelet Transform based Orthogonal Frequency Division Multiplexing-Interleaver Division Multiple Access (OFDM-IDMA) system for next generation wireless communication system. With IDMA, interleavers are the only means of user separation. In Discrete Fourier Transform based OFDM-IDMA systems, signals only overlap in the frequency domain while the Wavelet Transform signals overlap both in the time and frequency domains, so there is no need for the cyclic prefix (CP) in the proposed model. Performance of the proposed model is experimented and compared for different BPSK, QPSK, 16 QAM channel with transmitter & receivers and observed better BER. Also compared for different wavelet families and found the suitable with Daubechie wavelet. The proposed model Comparisons with other alternative technologies such as DFT-OFDM-IDMA is provided. The proposed model is discussed for multi-user detection, flexible rate adaptation, frequency diversity, and significant advantages regarding spectral and power efficiency. This paper concludes with efficient performance of the system which can be considerable for next wireless communication system.

In 2013 Minaxi , Prabha&Rajan in their research paper titled **Evaluation Of BER For Various Fading Channel In DWT Based MIMO-OFDM System** presented DWT based MIMO-OFDM system. Compare to the FFT based MIMO-OFDM it has lot advantages. There is no need for cyclic prefix, flexibility and optimal resolution. Ripple(Wavelet) concept has developed as a fresh scientific implement with the aim of preserve be functional in several applications such as processing of image, biomedical manufacturing, radar, physics, organize systems also message systems. The essential region of purpose of ripples in communication system: numerous accesses. A fresh modulation/multiplexing scheme consuming ripple transform remained planned for (3rd production organization project) 3GPP systems. This fresh modulation system implemented in (orthogonal frequency division multiplexing) OFDM scheme in addition to conventional based(FFT) transform blocks is replaced by wavelet transform blocks. There are many multiplicity of ripple transforms are offered, out of which four were chosen. They are Haar, Daubechies, Bi-orthogonal and reverse Bi-orthogonal transforms. Haar wavelet is best one of among all types of wavelet. The performance of DWT based MIMO-OFDM is calculated by bit error rate (BER) in various channel that is AWGN channel and Rayleigh channel. Using MATLAB-Simulation which channel is best for the DWT based MIMO-OFDM.

In 2011 Veena&Swamy in their research paper titled **Performance analysis of DWT based OFDM over FFT based OFDM and implementing on FPGA** propose a DWT-IDWT based OFDM transmitter and receiver that achieve better performance in terms SNR and BER for AWGN channel. It proves all the wavelet families better

over the IFFT-FFT implementation. The OFDM model is developed using Simulink, various test cases have been considered to verify its performance. The DWT-OFDM using Lifting Scheme architecture is implemented on FPGA optimizing hardware, speed & cost. The wavelet filter used for this is Daubechies (9, 7) with N=2. The RTL code is written in Verilog-HDL and simulated in Modelsim. The design is then synthesized in Xilinx and implemented on Virtex5 FPGA board and the results were validated using ChipScope.

In 2010 Abbas in his research paper titled **A Novel Radon-Wavelet Based OFDM System Design and Performance Under Different Channel Conditions** both Finite Radon Transform and Discrete Wavelet Transform are implemented in a new design for orthogonal frequency division multiplexing. The new structure was tested and compared with conventional Fast Fourier Transform -based orthogonal frequency division multiplexing, Radon-based orthogonal frequency division multiplexing, and discrete wavelet transform -based orthogonal frequency division multiplexing for additive white Gaussian noise channel, flat fading channel, and multi-path selective fading channel. Simulation tests were generated for different channels parameters values. The obtained results showed that proposed system has increased spectral efficiency, reduced inter symbol interference and inter carrier interference, and improved bit error rate performance compared with other systems.

In 2006 Li-Ping and others in their research paper titled **Interleave-Division Multiple-Access** provides a comprehensive study of interleave-division multiple-access (IDMA) systems. The IDMA receiver principles for different modulation and channel conditions are outlined. A semi analytical technique is developed based on the density evolution technique to estimate the bit - error- rate (BER) of the system. It provides a fast and relatively accurate method to predict the performance of IDMA scheme.

4. Analysis of above Works and Problem Formulation

Following problems were identified based on the above literature review:-

- 1) The analysis of the systems discussed in the literature consists primarily of a single type of channel. Their research development was concentrated on a single channel.
- 2) There is wide number of research work on wavelet based OFDM , OFDM IDMA , but little interest has been given on the development of Radon Transform technique described by Abbas as shown in literature review.
- 3) Several models and research work on OFDM focused on the individual analysis of systems that includes BER, SNR, but a comparative analysis needs to be done in order to get a holistic picture of the complete process.

4.1 Proposed Work

- 1) It has been proposed to use Radon Transform for implementing OFDM-IDMA.

- 2) Channels on which the system is to be simulated will be AWGN and Rayleigh Fading Channel.
- 3) To perform a comparative analysis of the wavelet transform based OFDM –IDMA , FFT based OFDM – IDMA and Radon based OFDM-IDMA

5. Conclusion

In this review paper a comprehensive study about OFDM systems is undertaken. Special emphasis has been given on the prospects of OFDM-IDMA as opposed to OFDM-CDMA. Thus this paper summarizes various implementation techniques by which OFDM-IDMA has been implemented in the pat. Also a future research work has been proposed which could help the research scholars to undertake the problem in a more holistic approach.

References

- [1] Al-Dhahir N. and Cioffi J. "Optimum Finite-Length Equalization for multicarrier Transceivers," Computer Journal of IEEE Transactions communications, vol. 44, no. 1, pp. 56-64, 1996.
- [2] Al-Jawhar W., Kattoush A., Abbas S., and Shaheen A., "A High Speed High Performance Parallel Radon Based OFDM Transceiver Design and Simulation," Computer Journal of Digital Signal Processing, vol. 18, no. 11, pp. 907-918, 2008.
- [3] Beylkin G., "Discrete Radon Transforms," Computer Journal of IEEE Transactions Acoustic, Speech, and Signal Processing, vol. 35, no. 2, pp. 162-172, 1987.
- [4] Bolker D., "The Finite Radon Transform," Integral Geometry and Contemporary Mathematics, vol. 63, no. 2, pp. 27-50, 1987.
- [5] Burrus S., Gopinath R., and Guo H., Introduction to Wavelets and Wavelet Transforms: A Primer, Prentice Hall, 1998.
- [6] Cimini L., "Analysis and Simulation of a Digital Mobile Channel Using Orthogonal Frequency Division Multiplexing," Computer Journal of IEEE Transactions on Communication, vol. 33, no. 3, pp. 665-675, 1985.
- [7] Deans R., The Radon Transform and Some of its Applications, John Wiley and Sons, 1983.
- [8] Graps A., "An Introduction to Wavelets," Computer Journal of IEEE Computational Science and Engineering, vol. 2, no. 2, pp. 50-61, 1995.
- [9] Goswami C. and Chan K., Fundamentals of Wavelets Theory, Algorithms, and Applications, John Wiley and Sons Ltd, 1999.
- [10] IEEE Std., IEEE Proposal for 802.16.3, RM Wavelet Based PHY Proposal for 802.16.3, Rainmaker Technologies, 2001.
- [11] Koffman I. and Roman V., "Broadband Wireless Access Solutions Based on OFDM Access in IEEE 802.16," IEEE Communication Magazine, vol. 40, no. 4, pp. 96-103, 2002.
- [12] Lawrey E., "The Suitability of OFDM as a Modulation Technique for Wireless Telecommunications, with a CDMA Comparison," Thesis James Cook University, 1997.
- [13] Lee I., Chow J., and Cioffi J., "Performance Evaluation of a Fast Computation Algorithm for the DMT in High-Speed Subscriber Loop," Computer Journal of IEEE Select Areas Communication, vol. 13, no. 9, pp. 1564-1570, 2007.
- [14] Lindsey R., "Wavelet Packet Modulation for Orthogonally Multiplexed Communication," Computer Journal of IEEE Transactions Signal Process, vol. 45, no. 5, pp. 1336-1337, 1997.
- [15] Mallat S., A Wavelet Tour of Signal Processing, Academic Press, 1999.
- [16] Mallat S., "A Theory for Multiresolution Signal Decomposition: the Wavelet Representation," Computer Journal of IEEE Pattern Analysis and Machine Intelligence, vol. 11, no. 7, pp. 674-693, 1989.
- [17] Minh N. and Martin V., "The Finite Ridgelet Transform for Image Representation," Computer Journal of IEEE Transactions Image Processing, vol. 12, no. 1, pp. 16-28, 2003.
- [18] Mohammed J., "VIDEO Image Compression Based on Multiwavelets Transform," PhD Thesis, University of Baghdad, 2004.
- [19] Nee V. and Prasad R., OFDM for Wireless Multimedia Communications, Artech House, 2000.
- [20] Nghi H., Ha H., and Le-Ngoc T., "Bit-Interleaved Coded OFDM with Signal Space Diversity: Subcarrier Grouping and Rotation Matrix Design," Computer Journal of IEEE Transactions on Signal Processing, vol. 55, no. 3, pp. 1137-1149, 2007.