

Studies and Research on the Fracture of High-Density Polyethylene Welded Assemblies Used in Natural Gas Distribution Networks

Eugen Avrigean¹, Adrian Marius Pascu²

^{1,2}Lucian Blaga University, Faculty of Engineering, No. 4, Emil Cioran Street, Sibiu 550025, Romania

Abstract: *This paper aims to approach the means of eliminating the risk of pulling out the polyethylene pipe from the fitting assembly by using the finite element method. The topic of this paper results from the research conducted by the author by means of a questionnaire in the field of high density polyethylene natural gas distribution networks. Constructive solutions are developed based on the minimization of stress and strain in the polyethylene fitting - pipe assembly.*

Keywords: finite elements, modeling, optimization.

1. Introduction

Compared to the fracture of metals, the study of the fracture resistance of polymers is currently in an early stage [2]. Many of the required theoretical supports are not fully finalized and there are many situations where the concepts of fracture mechanics that apply to metals are no longer applicable to other materials. The fracture resistance of polymer materials has become a major concern recently, since they began to be used for critical structures.

In the case of metals, fracture and yield follow a yielding mechanism. Brittle fracture occurs in materials where deformability is low. Ductile metals, by definition, suffer extensive plastic deformations prior to fracturing. Low temperatures, high deformation rates, and the stress triaxiality favor brittle fracture even in the case of a material that, under normal conditions, has a tenacious behavior. [2]

From a general point of view, these principles can also be applied to polymers, but the microscopic details of the yield and fracture of plastics are much more different than for metals.

The polymers do not contain crystallographic planes and grain boundaries; they are made up of long molecular chains. The atomic fracture involves the dissolution of chemical bonds. A peculiarity of polymers is that these materials have two types of bonds: the main covalent bonds between carbon atoms and Van der Waals secondary bonds, between the segments of the molecule. The final fracture normally requires the disconnection of both links, but in many situations the secondary bonds play an important role in the deformation mechanism leading to fracturing. [2]

The factors governing the tenacity and ductility of the polymers include the deformation velocity, the temperature and the molecular structure. At high speeds or low temperatures (compared to the vitrification temperature T_v) the polymers tend to become fragile as there is not enough time for the material to respond to stress with a viscoelastic deformation or a large scale yield. [2]

By definition, fracturing is material separation. In the case of polymers, fracturing at the atomic level is called chain cleavage.

It is known that the theoretical resistance of the bond to most materials is by a few orders of magnitude greater than the measured fracture strength, which is the result of the micro-cracks that locally produce important stress concentrators. Another factor that helps the chain cleavage is that the molecules are not uniformly stressed. When a stress is applied to a sample made by a polymer, surely certain chain segments bear a disproportionate load that may be sufficient to locally overcome the bond strength. [2]

2. The Importance of Studying the Suggested Topic

During the researches in the field, it was observed that the cleavage of the assemblies takes place in the assemblies' areas because of the non-observance of the working conditions on the site. This non-compliance is due both to the welders that perform the welding itself and to the environmental conditions that alter the characteristics of the material and do not allow it to have the flexibility according to the data in the technical data sheets. [1]

The market study, carried out in collaboration with the National Regulatory Authority for Energy (NRAE), Eon Gaz Romania, Fusion Romania and Proconfort, covers the following objectives:

- To collect information on the structure and the volume of activities of the current recipients of polyethylene fittings and pipes;
- To identify the current requirements, the disagreements and the future needs of the current beneficiaries in order to improve the activity of the companies and to anticipate the future trend in their production;
- To identify new beneficiaries;
- To test the reaction of the industrial consumers to such actions, which are usually seen in a structured market economy.

Volume 6 Issue 6, June 2017

www.ijsr.net

Licensed Under Creative Commons Attribution CC BY

The research was carried out by means of a questionnaire, which was completed by a total of 164 people, representing engineers, project managers, overseeing gas works, certified welders, engineers and technicians authorized by NRAE responsible for welding techniques, etc. Contracts have been signed with NRAE, Eon Gaz Romania, Fusion Romania and PROCONFORT in order to support the suggested activities. The companies that participated in this study belong to the following areas (see Figure 1):

- Legislation on the use of natural gas pipes and fittings - National Regulatory Authority for Energy (NRAE) - 8;
- The largest network developer in the country - Eon Gaz România - 85;
- Manufacturers and distributors of materials: Fusion Romania, Romstal Valrom CIA Trade, Sibtab - 27;
- Network developers and maintainers: PROCONFORT, Eurowagen, Sinecon, Instal Grup, ConsPro, Standard Sanitare, etc. - 44.

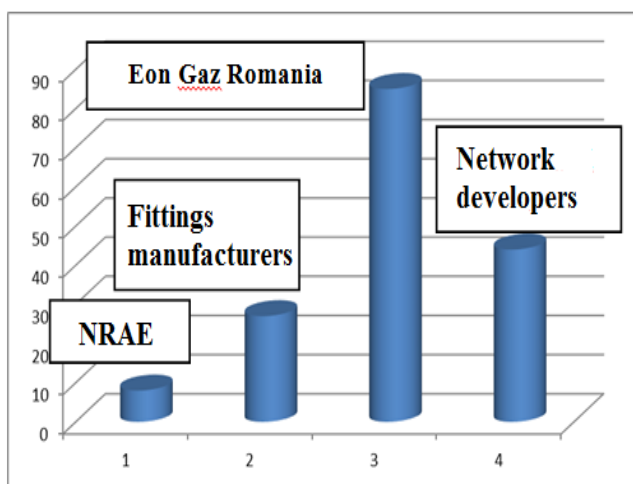

Figure 1: Distribution of the individuals participating in the inquiry

The questionnaires were analyzed using MS Excel and SPSS, and the results are presented as follows

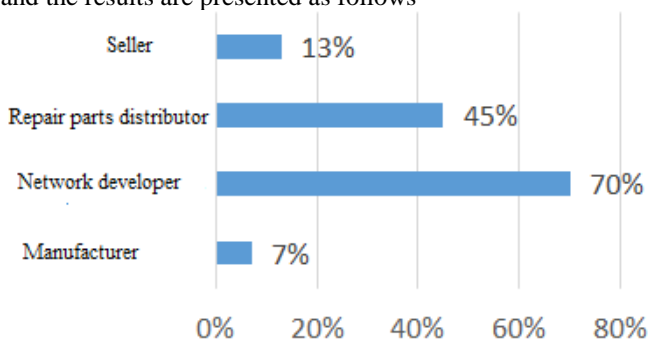

Figure 2: The use of polyethylene pipes and fittings

The interviewees use polyethylene pipes and fittings mostly for the development of new gas distribution networks, followed by the distribution of spare parts and the repairs on the gas network, as shown in Figure 2.

The respondents' profile: The preferred type of welding the polyethylene pipes and fittings is electrofusion welding. 35% of the respondents say they exclusively use this procedure and 41% say that 75% of the welding they do is done by

electrofusion. This indicates that the respondents are using modern techniques and this information is complemented by the following question related to the age of the equipment they use. More than 65% of the respondents' equipment is between 2 and 5 years old and very few respondents say that their tools and equipment are older than 6 years. Figure 3 shows that the origin of the welding equipment is mostly foreign. More than 81% of the respondents say they use mostly foreign instruments, while only 9% use Romanian equipment.

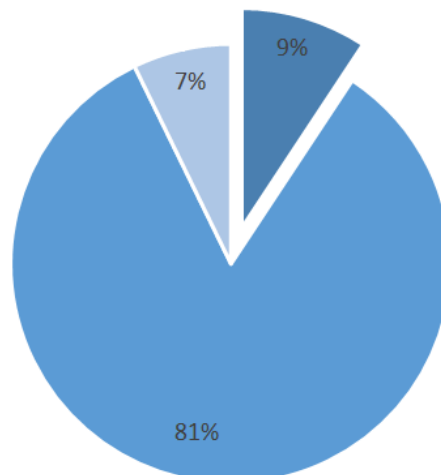

Figure 3: Type of welding equipment used

The research has highlighted the percentage of polyethylene pipes and fittings supplied by the major distributors in this field. Thus, 59% of the respondents said that more than half of their products are supplied by Fusion Romania, followed by Techoworld by 12% and Palplast. This item of the questionnaire reveals market behaviors that can be used by the decision-makers of the companies operating in the field of natural gas distribution networks.

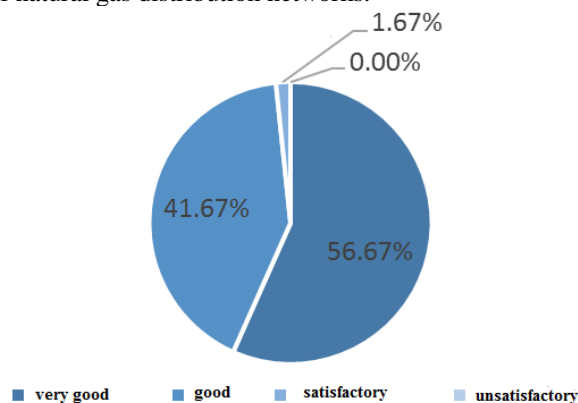

Figure 4: Customer satisfaction for the products offered by the market leader

One of the reasons for which Fusion Romania is the preferred manufacturer could be customer satisfaction. 56.67% of the respondents say that the quality of the products purchased from Fusion Romania is very good, 41.67% - consider the products to be good, while only 1.67% affirm that the quality is satisfactory. It is interesting to note that there is no customer who is totally disappointed with the quality of the polyethylene pipes and fittings manufactured by this company (see Figure 4).

Customer satisfaction is also very high in terms of services offered by this company. More than 93% of the customers believe that the services offered by Fusion Romania are good and very good, while only 1.72% consider that the provided services are unsatisfactory (see Figure 5).

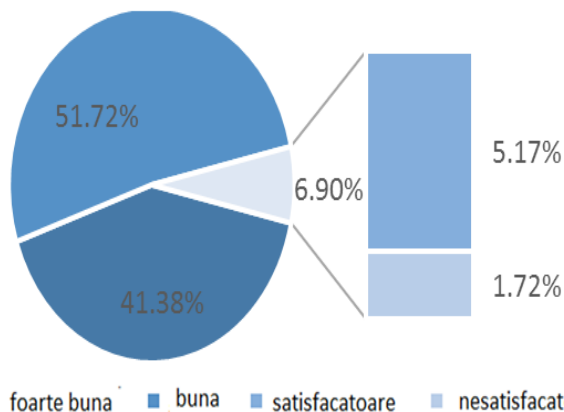

Figure 5: Customer satisfaction for the services provided by Fusion Romania

Regarding the customer's perception of the price for the quality ratio, 91.38% think that the ratio is good or very good and only 8.62% consider this ratio to be satisfactory. The respondents who operate in the field of gas distribution networks are optimistic about their future activities. Figure 6 shows that more than 36% believe that their business will develop in the near future and about 56% consider it will maintain the current work value.

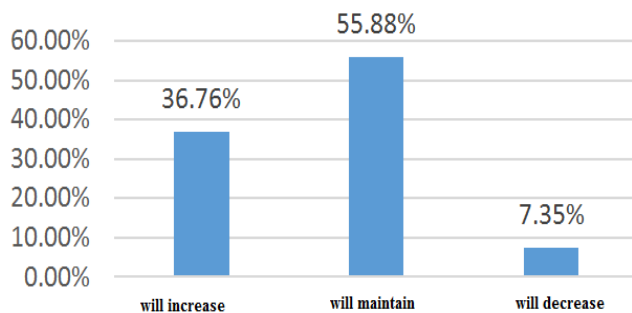

Figure 6: Estimate of future activities

The trends are similar when the interviewees were asked about their collaborations with other companies. The opinions slightly vary when the respondents were asked about the use of polyethylene pipes and fittings in the future. No one foresees a reduction in the use of these materials, while 57.58% believe there will be an increase in the use of polyethylene pipes and fittings, as shown in Figure 7. The last section of the questionnaire attempted to identify the most common defects and the flaws that arise in the use of the polyethylene pipes and fittings. As shown in Figure 8, the most common defect is the ovality of the pipe, being reported by more than 87% of the respondents.

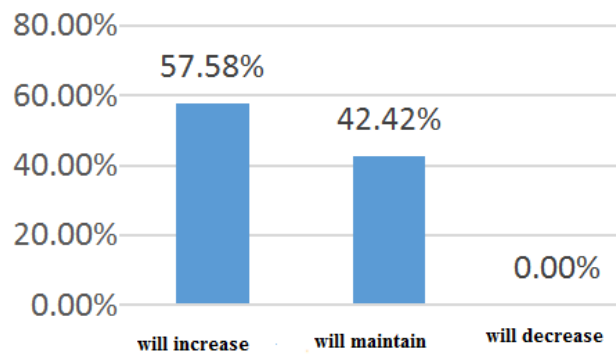

Figure 7: Opinions on the use of polyethylene pipes and fittings in the future

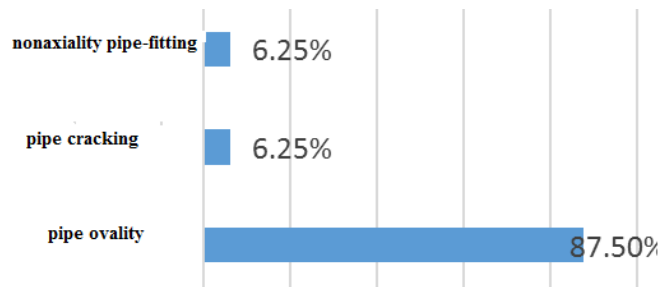

Figure 8: Main defects of the polyethylene pipes and fittings

Other problems have been identified in the welding process. The most common problem is ovality, being reported by more than 56% of the respondents. 36% of them say that the most common problem occurs in the welding process is burr inequality, while 7.27% consider the lack of edge flatness is the biggest problem they have to face when welding (see Figure 9).

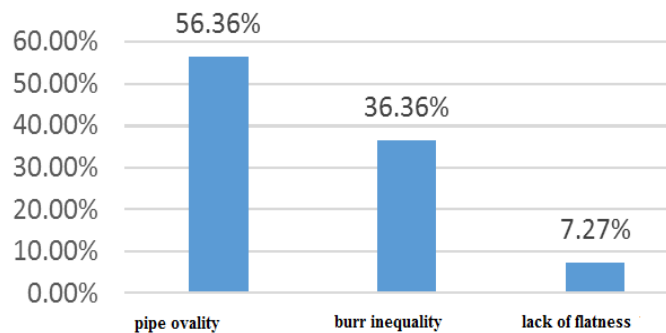

Figure 9: Defects occurring in the welding process

The errors occurring in electrofusion welding of the polyethylene pipes when using sockets have been inquired by means of an open ended question. Thus, the specialists could use their experiments without being constrained by some options. The most common problem that was reported by the respondents was the interruption of the spiral. Other problems were incomplete welding, material leakage or uneven melting, depending on the material's density. The problems encountered in the welding of the electrofusion fittings (see Figure 10) were similar to those mentioned above, but some problems concerning the variations in coaxiality, collinearity or stress have also been mentioned.



Figure 10: Electrofusion elbow

The questionnaire also identified the most common problems encountered while welding the T fittings and, in addition to those already identified, the specialist also mentioned bar code problems, metal insertion disruptions during the welding process, and leakage of information due to incomplete welding.

3. Finite Elements Study on the High Density Polyethylene Fitting - Pipe Assembly

The assembled elements can be varied (Figure 11), and the questionnaire inquiry proved that the most strained elements during the welding are the polyethylene elbows that were chosen for the study.



Figure 11: Elements used in assembling the polyethylene pipes

We analyzed a polyethylene assembly of Dn 32 mm diameter formed by a polyethylene pipe and a polyethylene elbow used in natural gas distribution networks.



Figure 12: Polyethylene elbow - pipe assembly

Following the welding and the thermal camera observation, it was noticed that the thermally stressed area is different from the mechanically stressed area and it was considered that this area is important for the study (Figure 13).

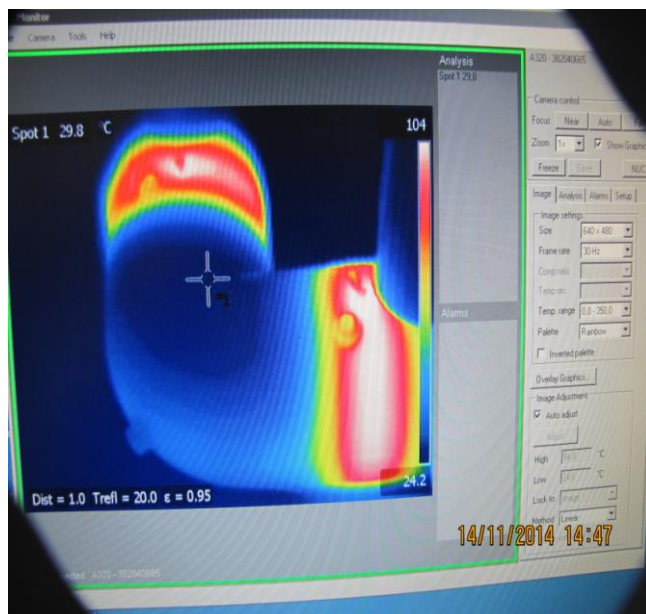

Figure 13: Thermally influenced area determined while welding the assembly

The polyethylene pipe and elbow were modeled using the Catia modeling and simulation software and the material characteristics for PE 100 polyethylene were applied. The chosen loads were applied in order to establish a basic stress and a basic strain that we are trying to optimize.

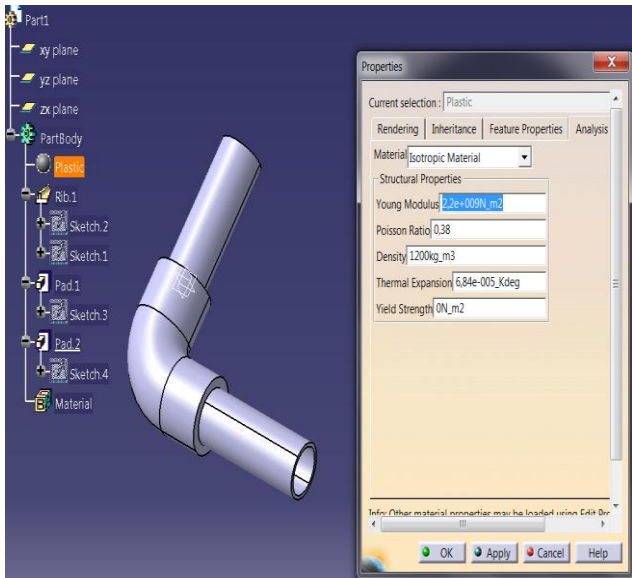

Figure 14: Applying the material characteristics to the polyethylene elbow - pipe assembly

The assembly was transferred in the finite element analysis module and it was subjected to a force of 1 kN.

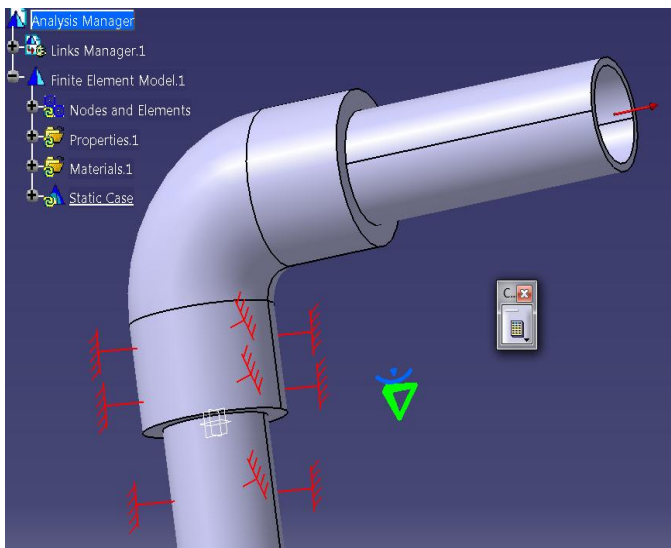

Fig. 15. Establishing the constraints and loads for the polyethylene fitting - pipe assembly

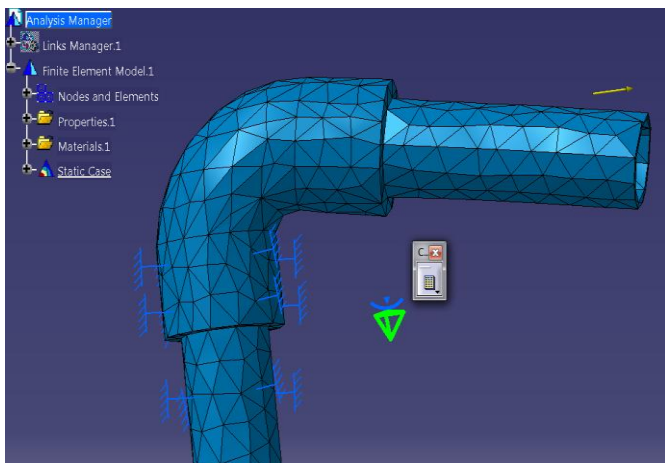

Figure 16: Meshing the part in finite elements

After the analysis was performed, the following values of the stress and strain for the required load were obtained (Figures 17 and 18).

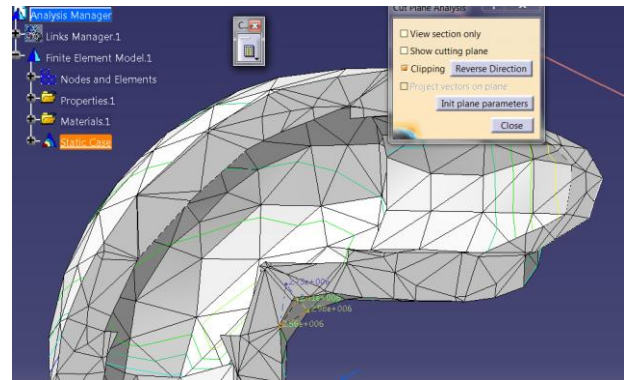

Figure 17: Von Mises Stress for the polyethylene fitting - pipe assembly (2.98 Mpa)

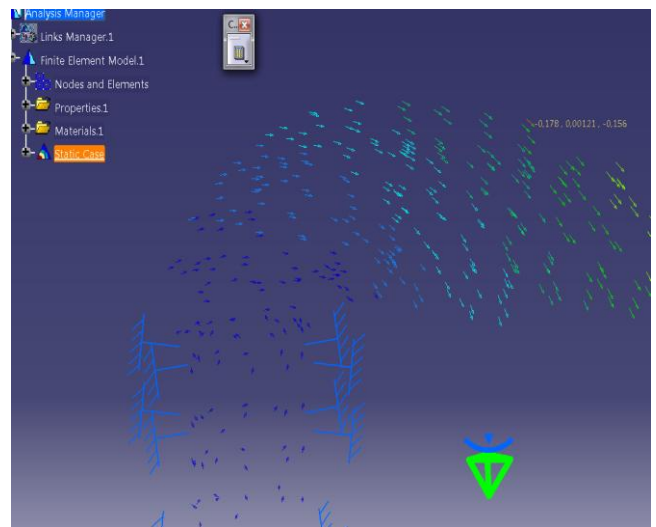

Figure 18: Value of the displacement obtained in the polyethylene fitting - pipe assembly (d = 0.178 mm)

It was considered useful to achieve an outer rib on the minimum radius that influences the material consumption by 3% but decreases the stress value from 2.98 MPa to 2.04 MPa (Figure 19). The value of the displacement will decrease from 0.178 mm to 0.161 mm.

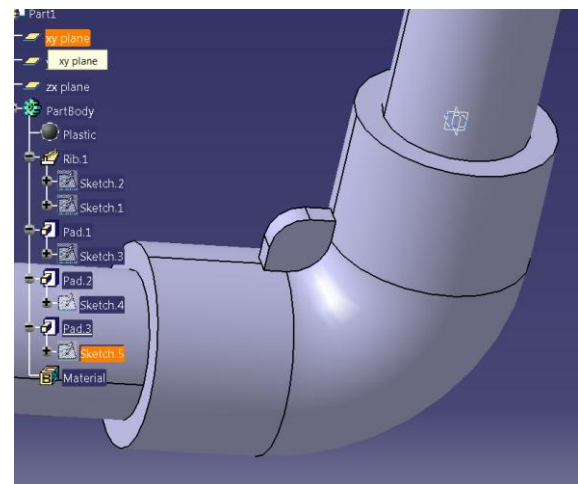

Figure 19: Changing the shape of the polyethylene elbow by inserting the outer rib

4. Remarks and Conclusions

Following the analysis of the problem resulted from the questionnaire inquiry, it was observed that an improvement of the shape of the elbow fitting of size Dn 32 could be made by introducing an external rib which will allow the decrease of the Von Mises stress.

Practically, the newly introduced rib requires a minor change in the injection mold and a minimal material consumption (maximum 3%) and the decrease of the Von Mises stress is about 32%.

References

- [1] Avrigean E. Study on Temperature Distribution in the Jointing Fittings for Polyethylene Natural Gas Pipes. 2015 3rd International Conference on Recent Trends in Materials and Mechanical Engineering (ICRTMME 2015) , January 15-16, 2015, Auckland, New Zealand.
- [2] Balan, M. L. Contributii la utilizarea procedeului de sudare cap la cap a tevilor de polietilena destinate transportului si distributiei gazelor naturale. Doctoral thesis. Sibiu
- [3] Oleksik, V., Pascu, A.M. Proiectarea optimala a masinilor si utilajelor, "Lucian Blaga" University Publishing House, Sibiu, 2007.

Author Profile



Avrigean Eugen - holder of a Ph.D. title in Mechanical Engineering, specialty Strength of Materials, faculty member in higher education (Lucian Blaga University - Engineering Faculty) and conducting research for 16 years. He has worked on numerous research books and articles, on laboratory studies, numerical analysis and computer aided design.