

# Modified Welch's PSD based on Parallel FFT

Sreelekha S<sup>1</sup>, Sabi S<sup>2</sup>

<sup>1,2</sup>Department of Electronics and Communication, Sree Budha College of Engineering, Kerala, India

**Abstract:** Spectral analysis is the most widely used methods for data analysis in radar, communication, geophysics, oceanography, atmospheric science, astronomy, hydrology and biology. This paper presents a low-complexity modified algorithm and architectural view to compute the power spectral density (PSD) using the Modified Welch Method. Welch's method is asymptotically unbiased estimate of the power spectrum by averaging the subsample periodograms. Welch algorithm also provides an excellent estimate of spectral power. But high computational complexity is the main drawback of Welch method. To reduce the high computational complexity use 50% overlap by computing N/2-point FFT, where N is the length of the window and is merged with previous N/2-point FFT and then calculate the N-point FFT. Frequency-domain windowing operation is preferred for high performance. In order to improve the computational speed parallel FFT approach is used.

**Keywords:** power spectral density, low-power, low-complexity, Welch method, windowing, Fast Fourier Transform.

## 1. Introduction

Spectral Analysis is an important role in many application such as biomedical signal analyzer [1] for extracting information from the relevant data, analysis of radar and sonar signal [2] for distinguishing and tracking signals of interest [3], [4], and spectrum sensing [5], [6]. Power spectral density or spectral power is defined as the power of the input signal over a wide range of frequencies. Welch's method is the technique used for calculating the power spectral density based on fast fourier transform. Power spectral density  $P(w)$  is the fourier transform of the auto-correlation of the input signal  $\Phi_x(l)$  [7].

$$P(w) = \sum_{l=-\infty}^{\infty} \Phi_x(l) e^{-jwl} \quad (1)$$

Power Spectral Density can be calculated in two ways: parametric method and non-parametric methods. Some examples of parametric methods are autoregressive-moving average (ARMA) model identification, Minimum-Variance Distortion less Response Method (MVDR) and eigen decomposition based methods [8]. Periodogram and multiple-window methods are come under in non-parametric approach. Periodogram is calculated by computing Fast Fourier Transform.

Due to the availability of efficient FFT algorithms, the periodogram method is preferred over other parametric approaches. Welch PSD method [9] is a popular method to estimate the power spectral density and is a non-parametric method based on the periodogram. This low-complexity architecture suitable for low-power embedded systems. In Welch method, squared magnitude of the periodogram is calculated and then averaged the individual periodogram, which reduces the variance of power measurements. The final result is an array of power measurement Vs frequency bin.

This paper presents novel modifications to the Welch PSD method to derive a low-complexity architecture suitable for low-power embedded applications. Biomedical signal analysis [1] is one of the application where a dedicated hardware can be used in low-cost and low-power systems.

Constraints like area, performance and power consumption should be taken into consideration while trying to incorporate PSD computation into biomedical monitoring systems. Such systems impose strict constraints on power consumption.

The structure of this paper as follows. Section II provides brief overview of the power spectral density computation using the Welch method. Section III, gives the modified algorithm and FFT architectures and the related works in that field. Simulation results are discussed in Section IV Some conclusions are drawn in Section V.

## 2. PSD Computation

PSD computation based on the Welch method which involve dividing the signal into multiple segments, then the modified periodograms of these segments are calculated and after that, averaging these modified periodograms. The normal algorithm description as follows,

- The input signal  $X(n)$  is divided into  $N$  overlapping segments.
- The specified window is applied to each segment.
- FFT is applied to the each windowed data.
- Each periodograms of new windowed data segment is computed which is periodogram.
- Taking the average of these periodograms to obtain power spectral density.

The Welch method [Welch 1967] is obtained from Bartlett method in two respects. First, the data segments in the Welch method are allowed to overlap another one is the windowing of each data segment, this is done before computing the periodogram. Mathematical form of Welch method can be described as,

$$Y_j(t) = Y_j((j-1)K + t) \quad \begin{matrix} t=1,2,\dots,M \\ j=1,2,\dots,S \end{matrix} \quad (2)$$

denote the  $j^{\text{th}}$  segment. In (1),  $(j-1)K$  is the starting point for the  $j^{\text{th}}$  sequence of observations. If  $K=M$ , then the sequences do not overlap (but are contiguous) and we get the sample splitting used by the Bartlett method (which leads to  $S=L$ )

N=M data subsamples). However, the value recommended for K in the Welch method is  $K = M=2$ , in which case  $S = 2M=N$  data segments (with 50% overlap between successive segments) are obtained. The windowed periodogram corresponding to  $y_j(t)$  is computed as

$$\phi_j(\omega) = \frac{1}{MP} \sum_{t=1}^M v(t) Y_j(t) e^{-j\omega t} \quad (3)$$

where P denotes the power of the window function  $\{v(t)\}$ :

$$P = \frac{1}{M} \sum_{t=1}^M |v(t)|^2 \quad (4)$$

The Welch estimate of PSD is determined by averaging the windowed periodograms in (3):

$$\phi_w(\omega) = \frac{1}{S} \sum_{j=1}^S \phi_j(\omega) \quad (5)$$

### 3. Low-Complexity Power Spectral Density

The low-complexity Modified Welch algorithm is presented in this section. The main idea behind this is to compute the FFT of the individual non-overlapped segments (i.e., half of the actual segments) and then generate the FFT of the overlapped segments by combining the non-overlapped segments. Fig1 shows the flow chart of modified Welch algorithm. In the modified algorithm the input signal vector is divided into  $(L+1)$  non-overlapping segments of length  $N/2$ . To each segment we apply an  $N/2$  - point FFT. We obtain an  $N$ -point FFT by merging two  $N/2$ -point FFTs and the specified window is applied to it. Modified periodograms of each windowed segment is then calculated and is averaged to form the spectral estimate. Fig2 shows the filter circuit used for windowing in frequency domain.

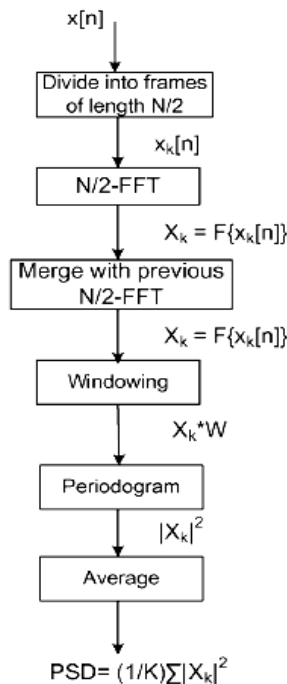

**Figure1** : Flow chart of Modified Welch Method

The window function for these non-overlapped segments will be different over two consecutive segments. Therefore, the windowing operation performed in the frequency domain.

The proposed modifications include two new steps in the algorithm: windowing operation has to be performed in frequency domain, and merge two  $N$ -point FFTs into an  $N$ -point FFT.

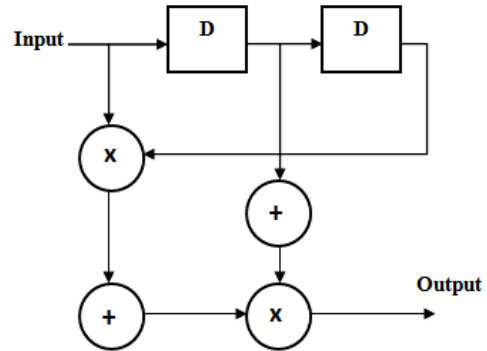

**Figure2:** Filter Circuit for Windowing

We can see that the core components incorporated in the modified algorithms such as FFT and Absolute-Square Multiple Accumulator (AMAC). The function of AMAC circuit is to compute the periodograms and average them over L segments. Absolute-square multiple accumulator (AMAC) circuit is similar to the multiply multiple-accumulator (MMAC) in [10]. Fig3 illustrates architecture for the AMAC block for a completely sequential computation. In this figure, the AMAC block stores the values of L different periodograms. The number of registers depends on the size of the FFT used in the PSD computation. The address decoder and multiplexers are correctly accumulating the periodogram outputs.

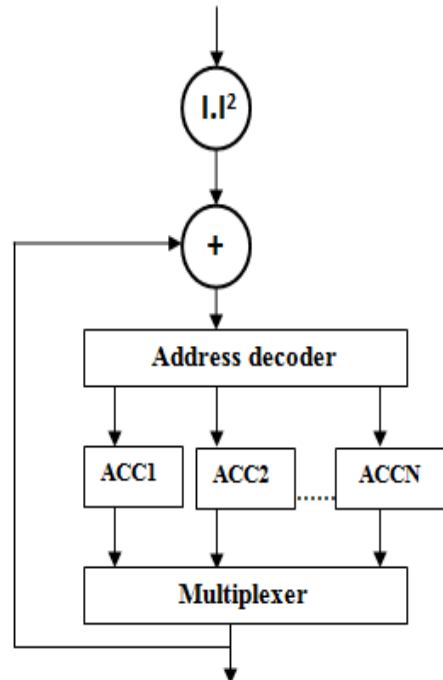

**Figure 3:** Absolute square-multiple accumulator (AMAC) circuit.

#### A. Fast Fourier Transform Architecture

Discrete Fourier Transform (DFT) is the most important technique used in digital signal and image processing applications. It has been usually implemented in digital communication systems such as Radars, Ultra Wide Band receivers and image processing applications. The direct

insight of this algorithm done using N-sample input, requires a large number of operations (N<sup>2</sup> complex multiplications and N(N-1) complex additions).

To minimize the number of operations Cooley- Tukey [1] introduced a fast algorithm called Fast Fourier Transform (FFT) [11]. FFT was developed to efficiently and effectively speed up its Computation time and significantly reduce the hardware cost. Commonly, FFT analyzes an input signal sequence by using decimation-in-frequency (DIF) or decimation-in-time (DIT) decomposition to build up an efficiently computational signal-flow graph (SFG). The latter, consists on decomposing DFT computation into small building blocks called radix-2 by using efficiently the symmetry and the periodicity of the twiddle factors. This decomposition minimizes the complexity from O(N<sup>2</sup>) to O(NlogN)

FFT algorithm can be implemented on software platforms such as General Purpose Processor (GPPs) and Digital Signal Processors (DSPs) and in hardware circuits including Field Programmable Gate Arrays (FPGAs) and Application Specific Integrated Circuits (ASIC). FPGA design of FFT is often adapted to fit high speed on low-power specification due to the reality that FPGAs have grown in capacity and performance and decreased in cost.

Here, our work employs a DIF decomposition with parallel FFT. Parallel FFT architectures are fast and high throughput architectures with parallelism. Compared to other architectures, it offers high throughput and energy efficient implementations with small latency but the hardware complexity is little high and less flexible.

**B. FFT Algorithm**

Fast Fourier Transform (FFT) is widely used method for computing Discrete Fourier Transform (DFT). The discrete Fourier transforms (DFT), X(k) of N-point discrete-time signal x(n) is defined by:

$$X(k) = \sum_{n=0}^{N-1} x(n) W_N^{kn} \quad k=0,1,\dots,N-1 \quad (6)$$

Where,  $W_N^{kn} = e^{-j2\pi kn/N}$

Figure3.4 shows the signal flow graph of 32-point Decimation-In-Frequency (DIF) radix-2FFT. FFT algorithms composed of butterfly calculation units as illustrated in Fig4.

$$X_{m+1}(q) = X_m(p) + X_m(q) \quad (7)$$

$$X_{m+1}(q) = [X_m(p) - X_m(q)] W_N^r \quad (8)$$

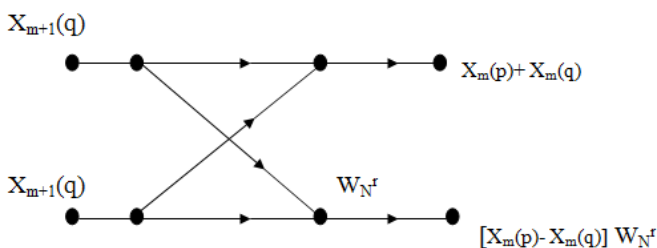
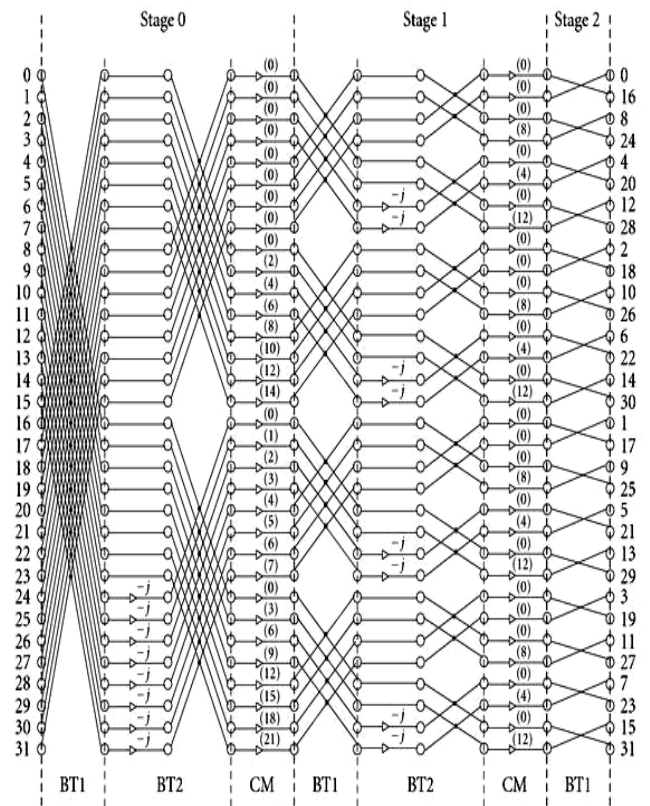

**Figure4:** Butterfly Scheme

Equation 7 and 8 describe the radix-2 butterfly operation at stage m as shown in Fig5

**4. Simulation Results**

The PSD estimation using Modified Welch method is subjected to behavioral simulation, synthesis, implementation and post-layout simulation using the Xilinx ISE Design Suite 14.7. Verified its functionality using different test vectors using Xilinx ISim Simulator. Implementation followed the step explained as above. The design entry is done using VHDL. ISim, which provides a complete, full-featured HDL simulator integrated within ISE, is used for both behavioral simulation and post-layout simulation. Xilinx Synthesis Technology (XST) is used for the synthesis of HDL designs to create Xilinx specific netlist files. High performance is the advantage of this system.



**Figure 5:** Signal flow graph of 32-point radix-2 FFT

**A. Graphs for FFT Computation Using Parallel Approach:**

The output waveform of the Fast Fourier transform computation obtained is as shown in the fig6

The output for the first stage is available immediately after the corresponding inputs are obtained unlike in the normal N-point FFT. In our computation 16-point R2SDF DIT FFT structure is used. We choose 16-bit input signal. In the first stage the input signal is real in nature. But the twiddle factor multiplication makes the input to the successive stages complex.





Figure 6: Output Waveforms of the Fourier Transform Computation

### B. Graphs for windowing

The results of the windowing function of real and imaginary outputs of FFT is shown in fig7.

The window function is obtained in frequency domain. Windowing is done in order to reduce the number of non-zero coefficients. Window function is applied separately for real and complex outputs of FFT.

### C. Graphs for Periodogram Operation

The modified periodogram of each windowed segment is computed. To each of the real and complex window output periodogram is applied. Periodogram is simply the square of the windowed data output. The results of the periodogram operation is shown in fig8.

The periodogram output is then averaged to obtain the final result. Since the input series is divided into segments of length 16, the periodogram output is averaged for 16 values. The averaged value gives the spectral power. The final power spectral density estimate is shown in fig9.

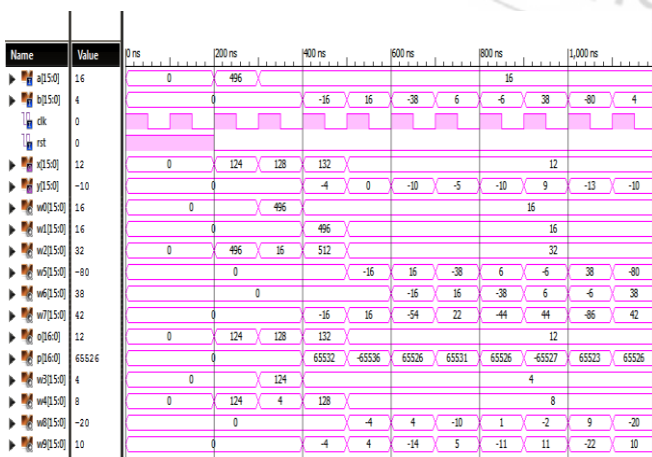

Figure 7: Output Waveforms of Window Function Of Real and Imaginary Outputs

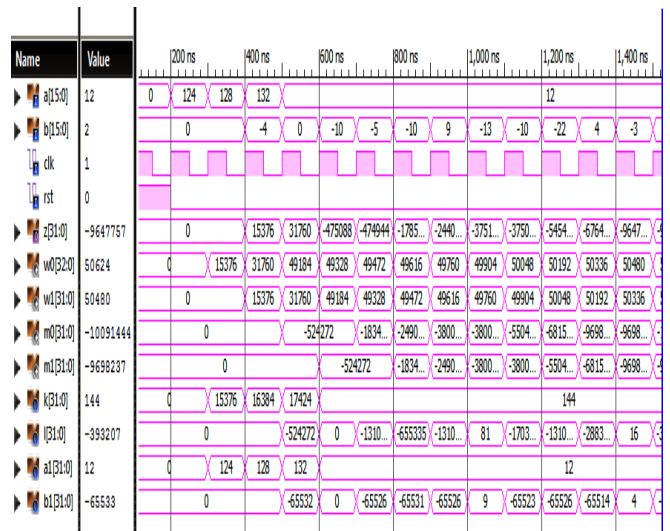

Figure 8: Output Waveform of Modified Periodogram

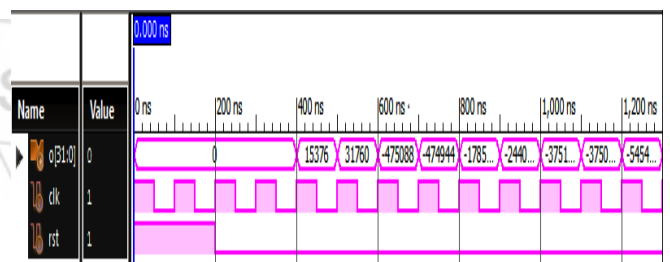

Figure 9: PSD Computation output

## 5. Conclusion

In the presented paper designed a parallel architecture instead of pipeline in Welch PSD calculation which gives better and faster computation than pipeline design. Performance loss is the main disadvantage of the pipeline architecture but it reduces the area .High latency is another drawback of this system. These can be overcome by using parallel structure. Similarly, it could increase maximum throughput.

The Modified Welch PSD computation suitable for low-power application. The proposed method can be used for processing signals like speech, electroencephalogram (EEG), electrocardiogram (ECG) etc. Further improvements can be made in the FFT which again leads further reduction in the computation complexity and there by reduces the chip-area.

## References

- [1] Y. Park, L. Luo, K. K. Parhi, and T. Netoff, "Seizure prediction with spectral power of EEG using cost-sensitive support vector machines," *Epilepsia*, vol. 52, no. 10, pp. 1761–1770, Oct. 2011.
- [2] F. El-Hawary and T. Richards, "A systolic computer architecture for spectrum analysis," *Proc. OCEANS*, vol. 4, pp. 1061–1065, Sep. 1989.
- [3] P. Stoica and R. L. Moses, *Introduction to Spectral Analysis*. Englewood Cliffs, NJ, USA: Prentice-Hall, 1997.
- [4] M. Hayes, *Statistical Digital Signal Processing and Modeling*. New York, NY, USA: Wiley, 1996. 11, no. 1, pp. 116–130, 2009.

- [5] T.-H. Yu, C.-H. Yang, D. Cabric, and D. Markovic, "A 7.4 mW 200 MS/s wideband spectrum sensing digital baseband processor for cognitive radios," in *Proc. Symp. VLSI Circuits*, Jun. 2011, pp. 254–255.
- [6] T. Yucek and H. Arslan, "A survey of spectrum sensing algorithms for cognitive radio applications," *IEEE Commun. Surveys Tutorials*, vol. 14, no. 4, pp. 1492–1510, Dec. 2012.
- [7] A. Oppenheim and R. Schaffer, *Discrete Time Signal Processing*, 2<sup>nd</sup> ed. Englewood Cliffs, NJ, USA: Prentice-Hall, 1989.
- [8] S. Haykin, *Adaptive Filter Theory*, 4th ed. Englewood Cliffs, NJ, USA: Prentice-Hall, 2001.
- [9] P. D. Welch, "The use of fast fourier transform for the estimation of power spectra: A method based on time averaging over short, modified periodograms," *IEEE Trans. Audio Electroacoustics*, vol. AU-15, pp. 70–73, Jun. 1967.
- [10] V. Sundararajan and K. K. Parhi, "A novel multiply multiple accumulator component for low power PDSP design," in *Proc. IEEE Int. Conf. Acoustics, Speech Signal Process.*, Jun. 2000, vol. 6, pp. 3247–3250.
- [11] M. Ayinala and K. K. Parhi, "FFT architectures for real-valued signals based on radix-23 and radix-24 algorithms," *IEEE Trans. Circuits Syst. I, Reg. Papers*, vol. 60, pp. 1–10, 2013.

