

Implementation of GSM Integrated Digital Token Counter System

Swapna T. Vaidya¹, Aditya Thogita²

¹Dept. of Electronics and Telecommunication Engineering, Ballarpur Institute of Technology, Bamni, Ballarpur (M.S.) India.
Gondwana University, Gadchiroli

²Dept. of Electronics and Telecommunication Engineering, Assistant Professor, Ballarpur Institute of Technology, Bamni, Ballarpur.(M.S.)
India
Gondwan University, Gadchiroli

Abstract: *In this paper, we are going to introduce a new token system which can successfully reduce waiting time of the customers and crowd in the bank. The main aim of the research is to develop a model that integrates alert notification via SMS, to be sent to the customers to provide specific service according to the customer's requirement. Also these customers can update the progress of the data queuing via GSM communication. The target population covers mainly the customers at banks, though the study focuses on the bank line system mostly modified and extended further to serve many applications.*

Keywords: GSM Modem, Data Queuing, PIC microcontroller, Token system

1. Introduction

Today, reliable technology around us started gaining trust of common people and thereby making them comfortable to rely upon such emerging technology. The most enhancing technology that we are familiar with today is internet. Internet is most trustworthy, people starting using it because they can manage most of the things from anywhere in the world. Example for consistently increase in the use of internet is banking, ticket booking and so on. The reason for increase in online facility by the users because they want everything should move far, everything should happen within a blink. Because now we know how valuable the time is, we don't want to stand in the queue, waiting for our turn to come. To overcome this issue, token system technique is introduced. This system is successful in breaking the queue in front of the window. Digitation of the token system makes it more comfortable for the employees and also to customers to, because now they can sit in the bank premises instead of standing in a line. Still people have to spend their time in waiting of the number to come. In this project, we are going to introduce a new system which can successfully reduce the waiting time of the customer in the bank. Token system is specially designed to bring about to prefer, efficiency and comfort in places such as banks, railway stations, public utility offices, health care and other places where people have to wait on the line to get a service. Initial concept of token system is to reduce a real and apparent waiting time, speed up service delivery, improves services quality and increases customer satisfaction. In this project we are using GSM based token system. The GSM modem is used to send and alert SMS to the respective token holder before his turn to come.

2. Literature Review

Xin-kan Mu, Yong-hong Chen (March 2014)

[1] Short message service (SMS) is a technology that can use mobile devices to send and receive text message, with wide coverage area, high popularity, high reliability, low

expenditure, easy development and other characteristics. Using GSM module or short message platform of network, short messages can be sent and received between the computer and the mobile terminal. This paper has designed and realized a set of remote computer supervisory system based on SMS communication. The paper elaborates the communication means, hardware and software structure of the system and the working process of the software. The system has good application prospect in some domains, such as remote control, mobile control, miniature control, etc

M.Bhuvaneswari, S.Sukhumar (Nov 2013) [2] This research paper is based on the concept of automatic ticket vending machine by using RFID and Zigbee technique. In order to ensure the passenger journey with no quarrels and mesh we employ this ticket friend solution that replaces the traditional paper ticketing by RFID tickets and vouchers, vended through automated machine using smart cards, which improves the convenience and security of transaction. Ticket friend solution through automated machine enables the passenger to predetermine the transport details. In this automated system we replace the traditional ticket system by smart card that contains all details of the user including bank account information which is similar to the ATM card. This automatic ticket vending machine consists of display which shows the availability of buses for all destinations. The person can find out the destination place by pressing the buttons available on that machine with the help of zigbee. If the location is selected then the availability of buses along with the time is displayed. If the people confirm to go in certain bus, by using smart card the person can receive the tickets employing RFID technique and by showing the ticket in front of the bus the door opens automatically and after some predetermined seconds it gets closed. If the person is supposed to consume alcohol that is detected with the help of alcohol sensor and that person is not permitted inside the bus. Voice GPS is placed inside the bus and the display shows the route map. For that PIC microcontroller is already pre-programmed to do the operations. By using this we can minimize manpower in buses and ticket counters,

Volume 5 Issue 7, July 2016

www.ijsr.net

Licensed Under Creative Commons Attribution CC BY

predetermining of the bus can be done to find the destination exactly, safe journey can be assured without any disturbance and system based booking for easy usage. Voice talking GPS proposed in the transport make the passenger to identify their departing location.

Chimere Barron, Huiming Yu (July 2013) [3] Cloud computing is an emerging technological paradigm that provides a flexible and scalable information technology infrastructure to enable business agility. There are different vulnerabilities in cloud computing and various threats to cloud computing. We have investigated several real-world cases where companies' cloud was infiltrated by attacks. In this paper several types of attacks are discussed, real-world cases are studied, and the solutions that providers developed are presented. Our current research will also be discussed.

Aayush Aggarwal, R.C. Joshi (2012) [4] In this paper, a sophisticated remote home security system designed by combining the advantages of wireless sensor networks and GSM technology is presented. It can detect intrusion, fire etc. and inform the user remotely about the incidence with distance playing no barrier. The hardware of the system includes wireless transceiver XBEE along with Atmega microcontrollers, real time clock DS1307, DTMF decoder HT9170, Voice recording and playback IC APR9600 and some other components. The system software is developed in C language on CVAVR platform.

3. Methodology

The system flow occurs on GSM Modem and microcontroller. The GSM modem is a hardware link in the entire system. The overall working is controlled by specially designed controller code. An embedded C code compile with MPLABIDE compiler controls the functioning of microcontroller. The working of the entire system based on specially designed controller based software. It receives message from GSM modem through RS232 Port, decodes it, send back acknowledgement through GSM modem and performs various tasks based on the call received.

The smart data queuing system presented here has the following advantages:

- 1) Eliminates the long waiting time wasted in a queue.
- 2) Efficient method of token distribution
- 3) A completely digitized and error free token system
- 4) Remote registration and on the move token distribution system.
- 5) Reduction of the physical strain involved.

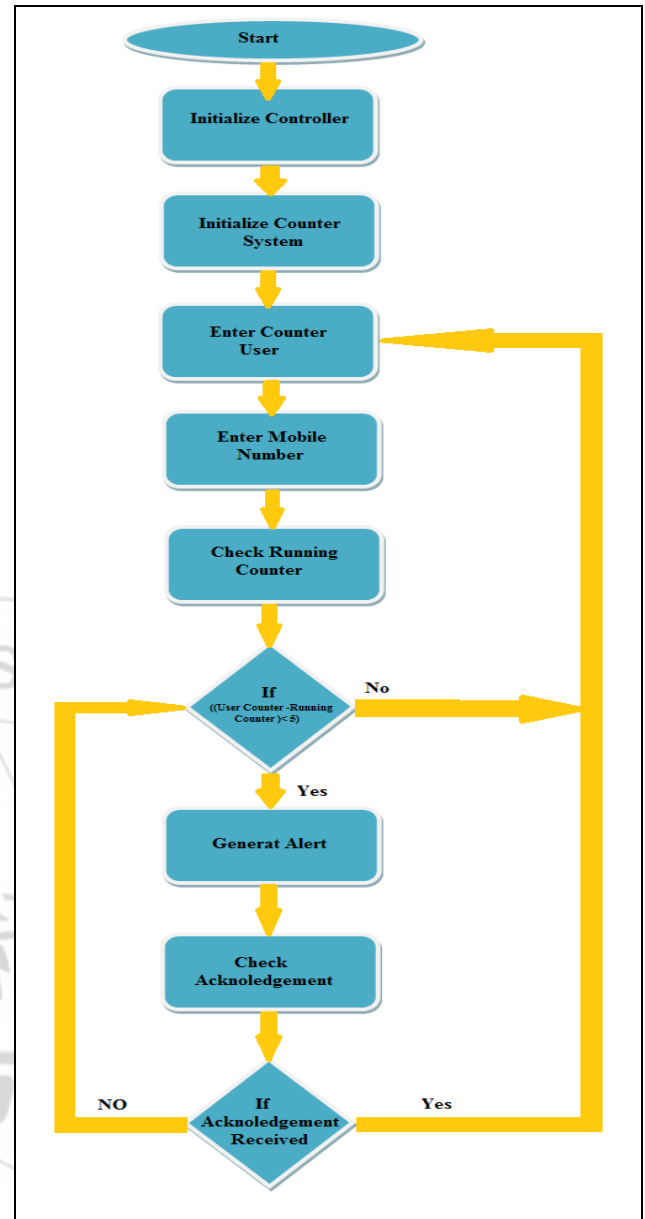

Figure 1: The working flow chart of the proposed system is shown above.

3.1 Working Principle

The working of the system can be divided into the following steps –

- 1) Receiving CALL from various Users.
- 2) Decoding it and updating the data memories in random and in queue format.
- 3) Sending acknowledgement to the Users via SMS.
- 4) Displaying Tokens and sending their Token numbers to the Users.
- 5) Flushing the queue.

In order to register for an appointment, the User has to CALL to the server number (GSM modem at the server side) in a fixed format. If one CALL's in the agreed format he/she will be appended to the queue and an acknowledgment message with the token number will be send to him. If the format of the CALL does not match with the predefined format then the user will be acknowledged with an error message. The next step is to send messages to the registered users for the

appointment. A user will receive two messages before his turn comes. First message will inform the time of the bank's arrival. For this to happen, the bank will have to send a message about his arrival time to the server machine (his/her clinic) and that message format is unique to the bank and it should reach the server at least 45 minutes before his/ her arrival. As soon as the server receives the time of bank's arrival, it will initially alert the first three users by sending an SMS. A display system, showing the token number will guide the users to cross check their token number again and then proceed for consultation. The server PC in the bank's room is provided with a controller, which will act as the front end interface. It will show all the details of the user as per the message received from the user earlier (during registration). The bank can also use a digital prescription pad and give a print out of the same to the user. The same prescription will be saved in the server PC as a file in the corresponding user's folder which will be created automatically during the user's consultation with the bank. The controller is also equipped with a search option, thus helping the bank to skip all those usual routine of checking the prescription again. The microcontroller (PIC) controls the display section. It receives a token number from server and displays it. Here, both the GSM modem and the microcontroller use the same transmission line of the server PC. The switching between the two is done with the help of a demultiplexer, which in turn is controlled by the server PC, so as to select one channel out of two, since one channel of the demultiplexer is connected to the GSM modem and the other to the microcontroller. This is achieved by the DTR line of RS232 and this line is again controlled by the controller code.

3.2 Algorithm

In this project we are using Data Queuing technique for saving time and memory utilization. The required algorithm that we have used for data queuing is given below.

Stacks and Queues

Two of the more common data objects found in computer algorithms are stacks and queues. Both of these objects are special cases of the more general data object, an ordered list. A *stack* is an ordered list in which all insertions and deletions are made at one end, called the *top*. A *queue* is an ordered list in which all insertions take place at one end, the *rear*, while all deletions take place at the other end, the *front*. Given a stack $S=(a[1],a[2],\dots,a[n])$ then we say that a_1 is the bottommost element and element $a[i]$ is on top of element $a[i-1]$, $1 < i \leq n$. When viewed as a queue with $a[n]$ as the rear element one says that $a[i+1]$ is behind $a[i]$, $1 < i \leq n$.

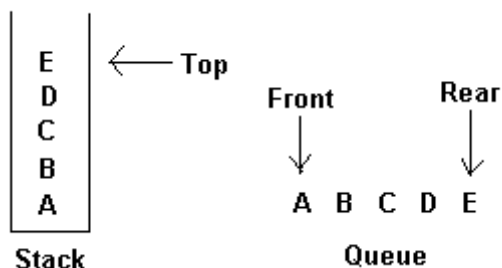

The restrictions on a stack imply that if the elements A,B,C,D,E are added to the stack, in that order, then the first

element to be removed/deleted must be E. Equivalently we say that the last element to be inserted into the stack will be the first to be removed. For this reason stacks are sometimes referred to as Last In First Out (LIFO) lists. The restrictions on queue imply that the first element which is inserted into the queue will be the first one to be removed. Thus A is the first letter to be removed, and queues are known as First In First Out (FIFO) lists. Note that the data object queue as defined here need not necessarily correspond to the mathematical concept of queue in which the insert/delete rules may be different.

Adding into stack

```
procedure add(item : items);
{add item to the global stack stack;
top is the current top of stack
and n is its maximum size}
```

begin

```
if top = n then stackfull;
```

```
top := top+1;
```

```
stack(top) := item;
```

```
end; {of add}
```

Deletion in stack

```
procedure delete(var item : items);
```

```
{remove top element from the stack stack and put it in the
item}
```

begin

```
if top = 0 then stack empty;
```

```
item := stack(top);
```

```
top := top-1;
```

```
end; {of delete}
```

These two procedures are so simple that they perhaps need no more explanation. Procedure delete actually combines the functions TOP and DELETE, stack full and stack empty are procedures which are left unspecified since they will depend upon the particular application. Often a stack full condition will signal that more storage needs to be allocated and the program re-run. Stack empty is often a meaningful condition.

Addition into a queue

```
procedure addq (item : items);
```

```
{add item to the queue q}
```

begin

```
if rear=n then queuefull
```

else begin

```
rear :=rear+1;
```

```
q[rear]:=item;
```

```
end;
```

```
end; {of addq}
```

Deletion in a queue

```
procedure deleteq (var item : items);
```

```
{delete from the front of q and put into item}
```

begin

```
if front = rear then queueempty
```

else begin

```
front := front+1
```

```
item := q[front];
```

```
end;
```

```
end; {of deleteq}
```

4. Hardware Methodology

The below figure is the block diagram of the proposed system the figure consists of a microcontroller, LCS display, 7-segment display and a GSM model.

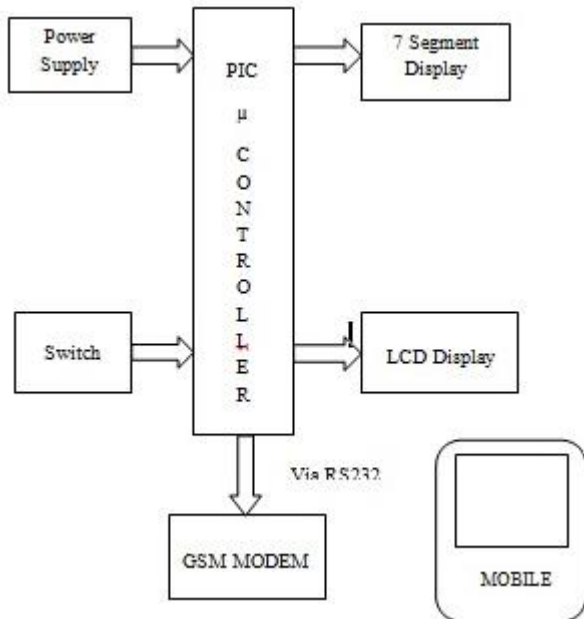

Figure 2: Block diagram of Proposed System

The system presented in the is project use GSM technology, GSM has shown it's promising nature, Standards and the ability to exchange and use information with Integrated service Digital Network. GSM is also the pioneer system to make scale use of the intelligent network concept, where many numbers of services which will be handled from a few centralized service centers. The paper discusses the efficient time management in various applications, through a data queuing system a microcontroller, making it embedded in nature. The entire system is controlled by a master controller program, and access to the Microcontroller is achieved through standard RS232 protocol.

The System comprises of three major elements:

- 1) A GSM (Global System for Mobile) modem
- 2) A microcontroller (PIC) for display.
- 3) Automatic SMS powering system.

The GSM modem acts as an interfacing element between the server machines (Bank) and the User. The communication is done through GSM communication technology. The system accepts CALL's from the various endusers and alerts the user by SMS's. The system accepts call from (different) various end users and alters the user by SMS. The synchronization between two communication is of highly managed by data queuing system. The software is designed in microcontroller and controls the total system flow. Here we are using AT command for SENDING and RECEIVING short message though GSM module. AT command not only can realize the setting of modules parameters but also can realize sending and RECEIVING of data, including controlling of SMS. GSM AT command has set three control modules for SENDING and RECEIVING short message. Block mode, text mode and PDU (protocol data unit) mode. Text mode is easy in sending and receiving short messages. Block mode is

gradually replace by PDU for default mode. Therefore, when selecting GSM module AT command, the content of the message should code or decode according to PDU format

5. Result

The Hardware of proposed system is shown below. The hardware shows various readings of running Token Counters of different user with memory and time utilization.

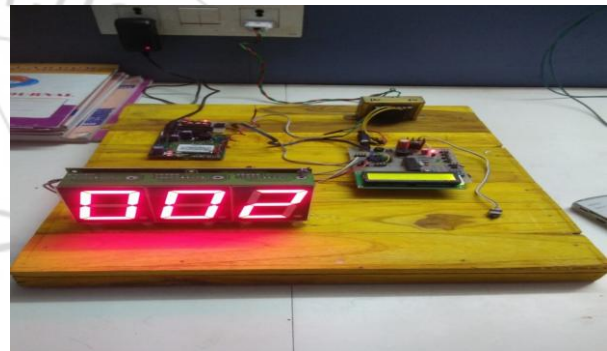
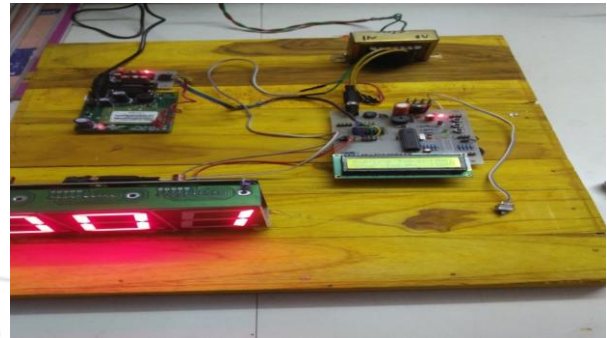

Figure 3: Displaying running Token number on 7 Segment display

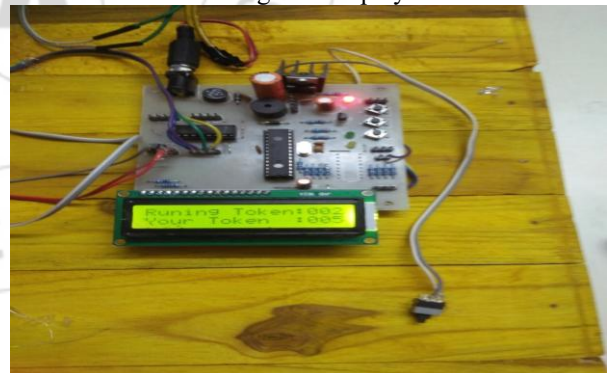

Figure 4: Displaying running Token number on LCD display

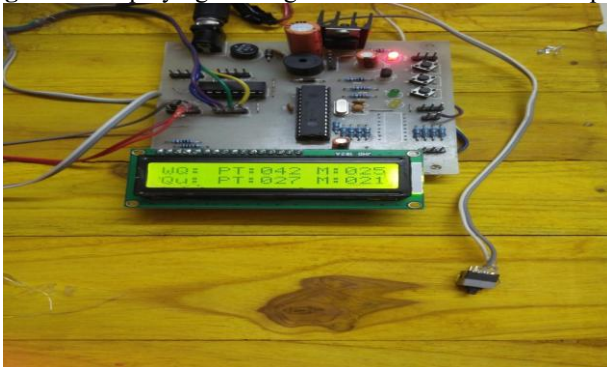
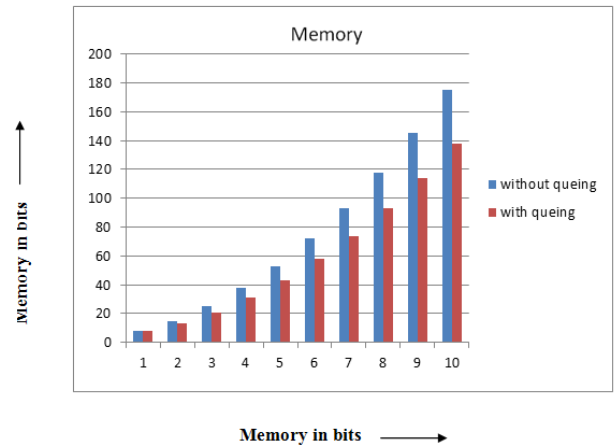

Figure 5: Displaying Process time and Memory utilization with Queuing and without Queuing

The figure 3 shows the running token numbers on the 7 segment display. When any User Call, their Call is automatically disconnected by the GSM modem and their token number is send to that User. Again, after some time the running Token number message is send to that User which will help him to come to Bank at proper time. Figure 4 shows the running token numbers on the LCD display along with User's token number. Figure 5 shows the processing time and memory utilization. In this, we can see **without queuing** how much processing time and memory is required and **with queuing** how much memory and processing time is required. From this we can easily manipulate the difference between time and memory utilization using both Queuing and without Queuing system.



In this project we have used different User in Case 1 and Case 2 for the detailed study of this system. And we have successfully recorded their call, and tested the time and memory utilization with queuing and without queuing system.

Case 2:

Table 2: Case 2: Another 10 different calls of users

Case 1:

Table 1: Case 1:10 different Calls of Users

Sr. No.	Case 1			
	Without Queuing		Queuing	
	Process Timing (ms)	Memory	Process Timing (ms)	Memory
1	0	8	0	8
2	17	15	11	13
3	42	25	27	21
4	75	38	47	31
5	114	53	72	43
6	160	72	102	58
7	214	93	136	74
8	275	118	175	93
9	342	145	218	114
10	417	175	265	138

Sr. No.	Case 2			
	Without Queuing		Queuing	
	Process Timing (ms)	Memory	Process Timing (ms)	Memory
1	14	13	9	12
2	35	22	22	19
3	64	33	40	28
4	100	48	63	39
5	142	65	90	52
6	192	85	122	68
7	250	108	159	85
8	314	133	200	105
9	385	162	245	128
10	465	193	295	152

Here, we are taking 10 different users in CASE 1 and CASE 2 and their Processing time and Memory utilization is shown. In Case 1 and Case 2 we can see how memory and time saved using Queuing and without Queuing Methods and their respective Graphs have been shown.

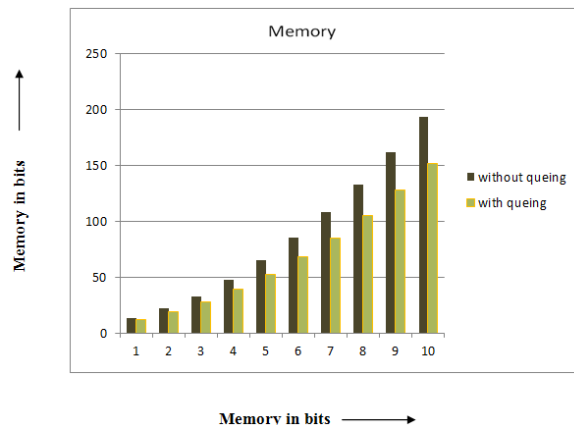
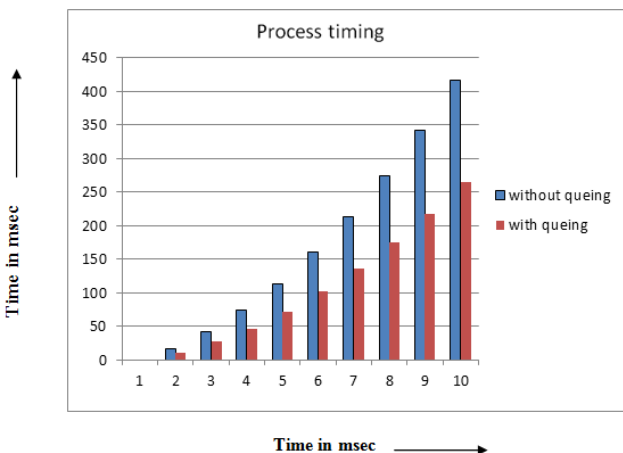
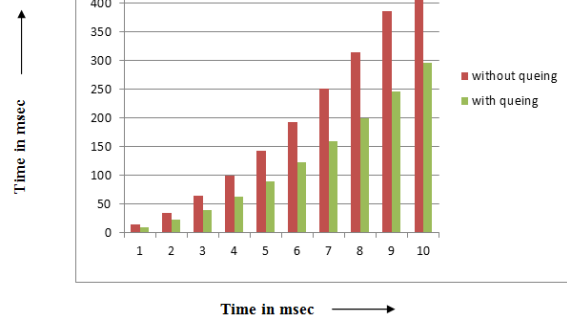

5.1 Advantages of a System

The system offer several attractive features like:

1. Convenience – SMS technology is easy to use and learn and can be accessed easily when needed.

2. Accessibility – instructions can be sent to the microcontroller to be controlled and monitored from any location provided there is the existence of an active GSM network or control from anywhere in world if cellular coverage is available.

3. Portability – a microcontroller can be controlled and monitored from any GSM phone that supports SMS. Considering the fact that most GSM phones support SMS, the system is therefore highly portable.

4. Saves Time – an SMS based remote monitoring and computer control system saves time as the user is not required to gain access to an internet connection or make a dedicated connection to the computer to be controlled as opposed to a Bluetooth-based system or an Internet based system.

5. Cheaper – SMS services are generally cheap and are sometimes provided for free (at least for certain periods) by service providers. Furthermore, most service providers do not charge users for receiving SMS.

6. Mobility – User and/or system administrators are more likely to have their phones with them at all times than they are likely to physically be in front of their computers. An SMS based system therefore enables them have ubiquitous access to the computer to be controlled and monitored.

7. Acknowledgement about execution of command from system to user.

8. To uses SMS and issue commands from user for control.

9. To alerts user on occurrence of any abnormal conditions like power failure, parameters.

10. To ease of implementation and cost effective approach.

5.2 Applications

- a) Hospitals.
- b) Banks.
- c) Railway & Bus Reservations.
- d) Every application where queue are present.

6. Conclusion

This project is a small step towards making life easy. The waiting time for ones turn to come in a long queue could be easily overcome by this project. Mobile phones gave a new dimension to the Remote access mode of communication system.

The main aim of this system is to minimize the waiting time in long queues and also to reduce the crowd in the premises. By installing this systems in such places will help people to save their time and it also help to cost of space requires for the construction of waiting room by reducing the crowd.

This project exploits the full facilities of GSM communication service. Hence establishing a strong reliable communication link between server and User. This project, guarantees an efficient synchronization between Man and Machine and step much clearer than the existing technology, ensuring the freedom of life.

The main aim of this project is to save Memory and Time which is done very efficiently in this Project.

6.1. Future Work

Making the system data base

For the different Users to save their numbers and details of the Users we have to make the System data base so we can store their details. Mentioning the future scope of the system, making the system database, thus making the system more efficient and smart.

References

- [1] Peter Sungu Nyakomitta and Vincent N. Omollo, Nov. 2014, "SMS-Based Alert Notification for Credit Applications Queuing Systems", International Journal of Innovation and Applied Studies
- [2] ISSN 2028-9324 Vol. 9 No. 3 Nov. 2014, pp. 1291-1302 © 2014 Innovative Space of Scientific Research Journals <http://www.ijias.issr-journals.org/>
- [3] Xin-kan Mu, Yong-hong Chen, March 2014, "SMS-based Remote Computer Supervisory Control System Design", JOURNAL OF SOFTWARE, VOL. 9, NO. 3
- [4] M.Bhuvanewari, S.Sukhumar, N.Divya, S.Kalpanadevi, N.Suthanthira Vanitha, November 2013, "Embedded System Based Automatic Ticket Vending Machine for Modern Transport System" International Journal of Advanced Research in Computer and Communication Engineering Vol. 2, Issue 11
- [5] Chimere Barron, Huiming Yu and Justin Zhan, July 3 - 5, 2013, "Cloud Computing Security Case Studies and Research", Proceedings of the World Congress on Engineering 2013 Vol II, WCE 2013, July 3 - 5, 2013, London, U.K.
- [6] Aayush Aggarwal and R.C.Joshi., 2012, "WSN and GSM based Remote Home Security System," IJCS Proceedings on International Conference on Recent Advances and Future Trends in Information Technology (iRAFIT 2012), pp.41 – 45
- [7] Amit Chauhan, Reecha Ranjan Singh, Sangeeta Agrawal, Saurabh Kapoor, S.Sharma., 2011, "SMS based Remote Control System," IJCSMS International Journal of Computer Science and Management Studies,11(02), pp.19 – 24
- [8] Mohd Helmy, Abd Wahab, Norzilawati Abdullah, Ayob Johari, Herdawatie Abdul Kadir., 2010, "GSM Based Electrical Control System for Smart Home Application,"

Journal of Convergence Information Technology, 5(01), pp.33 –39

- [9] Vijayarajet. al., 2010, “Automated billing system using GSM and ad-hoc wireless routing,” International Journal Of Engineering And Technology, 2(5), pp.343-347 Smart Queue Management System Using GSM Technology 949
- [10] Khondker Shajadul Hasan, Mashiur Rahman, Abul L. Haque, M. Abdur Rahman, Tanzil Rahman and M Mahbubur Rasheed., 2009, “Cost Effective GPS – GPRS Based Object Tracking System,” Proceedings of the International Multi Conference of Engineers and Computer Scientists IMECS
- [11] A. Tahat., 2008, “Implementation of an SMS-based telemedicine system for patient monitoring,” Proceedings of 4th IASTED, Maryland, USA, pp.223–228
- [12] I. Harris. Data in the GSM cellular network. In D. M. Balston and R.C.V. Macario, editors, *Cellular Radio Systems*. Artech House, Boston, 1993.
- [13] D. M. Balston. The pan-European system: GSM. In D. M. Balston and R.C.V. Macario, editors, *Cellular Radio Systems*. Artech House, Boston, 1993
- [14] Monali R. Dave, Jai Karan Singh, Mukesh Tiwari, Dr. Anubhuti Khare, “Implementation of Intelligent Polling System Using GSM Mobile”, International Journal of Computer Technology and Electronics Engineering (IJCTEE) Volume 1, Issue 2
- [15] Reima Suomi, Ari Serkkola, Markku Mikkonen, “GSM Based SMS Time Reservation System for Dental Care”, The International Journal of Technology and Human Interaction

Author Profile



Swapna Trimbak Vaidya received BE from Nagpur university in 2007 and pursuing her Mtech from Gondwana university. It is thesis of her final year project of Mtech.

Aditya Thogita completed his BE and Mtech. He is working as Assistant Professor at Ballarpur Institute of technology, Banni.