

Reduction of Vibrations and Noise using Nylon-66/Al₂O₃ Nanocomposite Gear Box in Lathe

A. Chennakesava Reddy

Professor, Department of Mechanical Engineering, JNTUH College of Engineering, Kukatpally, Hyderabad – 500 085, Telangana, India

Abstract: Exposure to excessive noise can damage hearing, and it is important to understand the effects of this kind of noise, particularly because such exposure is avoidable. The aim of the present work was to reduce vibrations and noise in the lathe machines using nylon-66/Al₂O₃ nano composite gears in the gear box. As per IRD General Machinery Vibration Severity Chart, the condition of the lathe is VERY SMOOTH as the vibration has been reduced to 85 VdB. The noise levels have been reduced to the permissible limit of 97 dB for the lathe machines with gear box having Nylon-66/Al₂O₃ nano composite gears.

Keywords: Vibration, noise, lathe, gear box, Nylon-66, alumina, nanocomposite gears

1. Introduction

Gears are critical components of a power transmission system used in machine tools like lathes. Legal regulations and customer demands arising from an increased focus on environmental and quality issues can result in requirements to lower vibrations and noise from gearboxes. Researchers and gear-industry experts agree that a transmission error is an important excitation mechanism for vibrations and noise [1]. Welbourn [2] defined transmission error as „the difference between the actual position of the output gear and the position it would occupy if the gear drive were perfectly conjugate.“ The ability to tailor the interface strength between the fibers and matrix enhances the ability to design for a specific damping capacity. It was observed that a low interfacial shear strength between the fibers and the matrix and a high interfacial area, lead to an increase in damping capacity [3]. Such damping capacity can be further increased if discontinuous fibers were used rather than continuous fibers to reinforce the matrix [4].

The objective of this paper was to experimentally investigate the influence of different types of gear materials to reduce vibrations and noise in the lathes used in an engineering workshop. To achieve the goals of the proposed project, the metal gears were replaced by Nylon-66/Al₂O₃ nanocomposite gears.

2. Design of Lathe Gear Box

Lathe is a machine tool which rotates the workpiece on its axis to perform various operations such as cutting, knurling, drilling, facing, taper turning, thread cutting, etc., with tools that are applied to the workpiece to create an object which has symmetry about an axis of rotation. The headstock of a lathe carries the head spindle and the mechanism for driving it. It comprises a spindle and mechanism for driving and altering the spindle speed. The spindle is hollow throughout its length so that bars or rods can be passed through it from the left and held in a chuck at the nose. The chuck end of the spindle is bored to a Morse taper to receive the solid center. At the other end of the spindle is the gear by which the spindle drives the feed and the screw-cutting mechanism through a gear train located on the left end of the lathe.

The spindle is subjected to considerable torque because it drives the work against the resistance of the cutting tool, as well as driving the carriage that feeds the tool into the workpiece. Because of the torque and pressure applied to the spindle, adequate lubrication and accurately adjusted bearings are absolutely necessary. The headstocks are classified into two categories based on the driving mechanism:

- all-belt driven headstock
- all-gear driven headstock

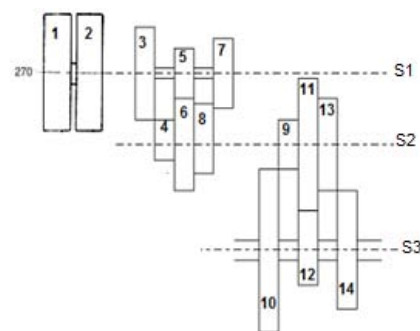

Figure 1: 9-speed geared headstock (1. Fast pulley, 2. Loose pulley, S1. Drive shaft, S2. Intermediate shaft, S3. Headstock spindle, 3, 4, 5, 6, 7, 8, 9, 10, 11, 12, 13, 14 are gears).

The all-gear driven headstock used in the lathes is shown in figure 1. The driving pulley at the left is driven at a constant speed by a motor located under the headstock. Various combinations of gears in the headstock transmit power from the drive shaft to the headstock spindle through an intermediate shaft. The speed-change levers are used to shift the sliding gears on the drive shaft and the intermediate shaft to line up the gears in different combinations. This produces the gear ratios needed to obtain the various spindle speeds. The lathe used in the present work had 9 speeds powered by 8 kW motor. The speed range was 90 to 1500 rpm.

Preferred number: 1.06, 1.12, 1.26, 1.41, 1.58, 1.78, 2.
The nearest preferred number in the list is 1.41. The various speeds in ascending order are as follows:
n₁ =1500; n₂ =1062; n₃ =755; n₄ =535; n₅ =380; n₆ =270; n₇ =191, n₈ =135; n₉ = 90

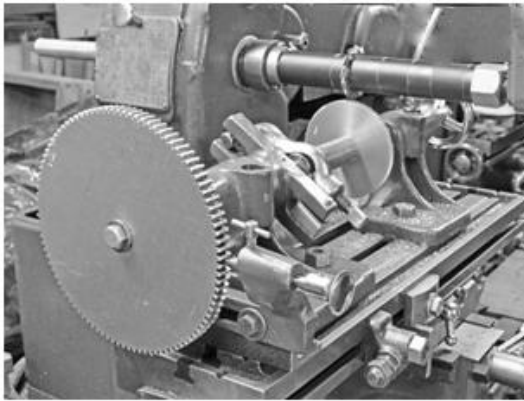

Figure 5: Manufacturing of gears on a milling machine.

With these settings the machine was started and traversed along the axis of the gear blank to cut the tooth over the entire width of the gear. Depth was increased slowly until it reached the full depth of the tooth. After one tooth space was cut, the blank was indexed through 1/z revolution by means of the dividing head, and the process was repeated until all the teeth were cut. The dimensions of the gears manufactured are given table 2. Samples of manufactured Nylon-66/Al₂O₃ nano composite gears are shown in figure 6.

Table 1: Designation and dimensions of gears

Sl.No.	Pitch diameter, mm	Quantity
3	200	1
4	100	1
5	125	1
6	175	1
7	150	1
8	150	1
9	100	1
10	280	1
11	250	1
12	130	1
13	190	1
14	190	1



Figure 6: Manufactured gears on milling machine.

3.3 Testing for Mechanical Properties

The samples were machined to get flat-rectangular specimens (figure 7) for the tensile tests. The tensile specimens were placed in the grips of a Universal Test Machine (UTM) at a specified grip separation and pulled until failure. The test speed was 2 mm/min (as for ASTM D3039). The load v/s displacement curve was obtained from the computer interfaced with the UTM. The hardness of the metal matrix samples were determined using Shore D hardness tester.

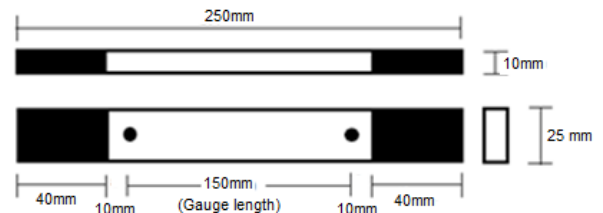

Figure 7: Dimensions of flat tensile specimen.

3.4 Measurement of Vibrations and Noise

The experimental set up to measure vibrations of three shafts and noise generated in the gear box is shown in figure 8. The PC based accelerometer was used to measure vibrations of shafts upon which the gears were mounted. Components of the PC based accelerometer (figure 9) are as follows:

- 1) Piezoelectric sensors with IEPE (Integrated electronic piezoelectric accelerometer) output are directly connected to the PC by the USB converter M302 / M312. Piezoelectric sensors with charge output are connected with an in-line charge converter.
- 2) M302 / M312 units are connected to the USB-input of the PC. The PC supplies the M302 / M312 with energy.
- 3) The instruments work on the PC-screen simultaneously.

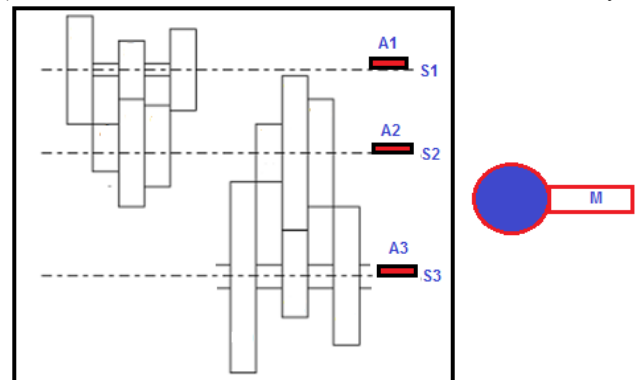

Figure 8: Experimental set up to measure vibrations and noise.

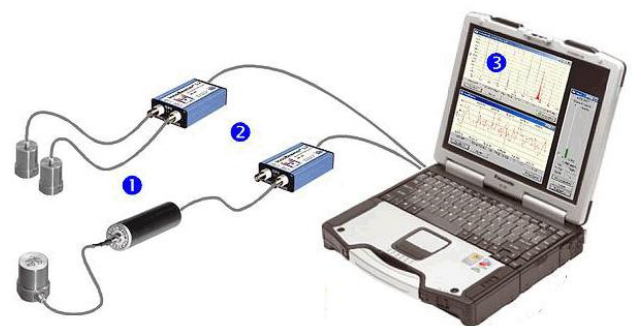

Figure 9: Integrated electronic piezoelectric accelerometer.

Sound pressure is the easiest of all acoustic parameters to measure, since it is only necessary to place a microphone in the sound field. Sound pressure is measured in Pascals, (1 Pa = 1N/m²), or in dB referred to 20 μPa. The sound pressure was measured in dB using digital noise meter as shown in figure 10.



Figure 10: Digital noise meter

4. Results

The tensile strength and hardness of Nylon-66/Al₂O₃ nano composite are, respectively, 102 MPa and 83 Shore D. The noise and vibration measurements were carried out at three different torque levels, 135, 380 and 1062 rpm of the spindle. The oil used in the gearbox was SAE 10W-30 engine oil and the temperature was 30°C at the beginning of the test and approximately 60°C by the end of the test. All test gears were manufactured within these tolerances, unless otherwise stated. The average of three readings was plotted for each machining conditions.

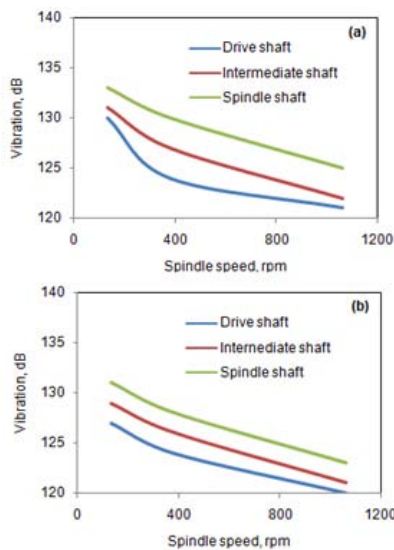

Figure 11: Effect of cast iron gears on vibration while machining (a) Cu-alloy rods and (b) Al-alloy rods.

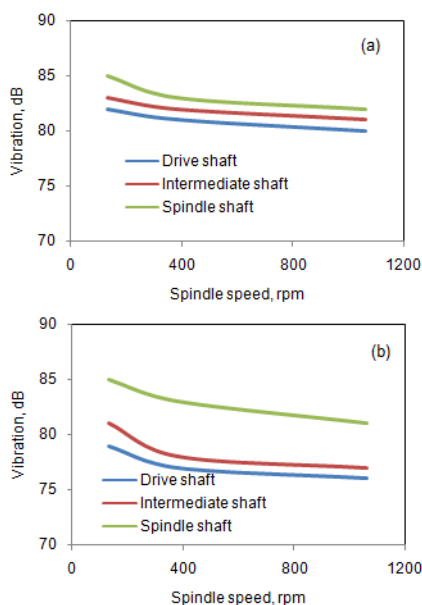

Figure 12: Effect of Nylon-66/Al₂O₃ nano composite gears on vibration while machining (a) Cu-alloy rods and (b) Al-alloy rods.

The effect of using cast iron gears and Nylon-66/Al₂O₃ nano composite gears in the gear box on the vibrations is shown in figures 11 and 12. The vibrations in the spindle shaft were higher than those in the drive shaft. The vibrations in the shafts were lower while machining Al-alloy rods than those generated while machining Cu-alloy rods. The vibrations decrease with increase of spindle speed.

The effect of using cast iron and Nylon-66/Al₂O₃ nano composite gears in the gear box on the noise is shown in figure 13. The noise generated from the gear box containing cast iron gears was higher than that produced Nylon-66/Al₂O₃ nano composite gears. The noise produced from the gear box was lower while machining Al-alloy rods than those generated while machining steel rods.

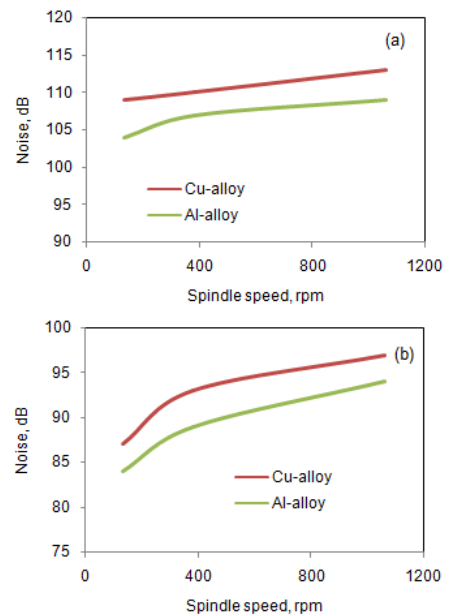

Figure 13: Effect of cast iron (a) and Nylon-66/Al₂O₃ nano composite (b) gears on noise.

5. Discussion

The vibration (figure 12) and noise (figure 13a) measurements showed values that were relatively high for the gear box having cast iron gears. The highest value (133 VdB) of vibration was observed while machining Cu-alloy rods at spindle speed of 135 rpm. The lowest value (120 VdB) of vibration was observed while machining Al-alloy rods at spindle speed of 1062 rpm. If the vibration is 115 < VdB < 121, the lathe condition is **Rough** [6]. If the vibration is VdB > 121, the lathe condition is **Very Rough**. Machines with vibration levels above the **Rough** region should be analyzed immediately for cause determination and shut down at the earliest opportunity for correction. This situation was aroused due to machining under dry conditions. When water soluble cutting oil was employed while turning rods on the lathe, the vibration was reduced to 107 VdB which gives **FAIR** (103 < VdB < 109) condition of the lathe [7]. The noise level was come down from 113 dB (figure 14a) to 101 dB (figure 14). The permissible noise limit for the machines is 108 dB [8]. The vibrations might be due to transmission error from the drive shaft to the spindle shaft. The transmission error would result from teeth disengagement, shaft deformation, lead crowning, involute alignment error, helix

angle error and backlash error. Kohler and Regan [9] investigated the effect of pitch errors on transmission error of a gear pair. Flodin [10] investigated mild wear of spur and helical gears. Wear simulations showed that for helical gears without lead crowning or tip relief, the simulated wear reduced calculated transmission error.

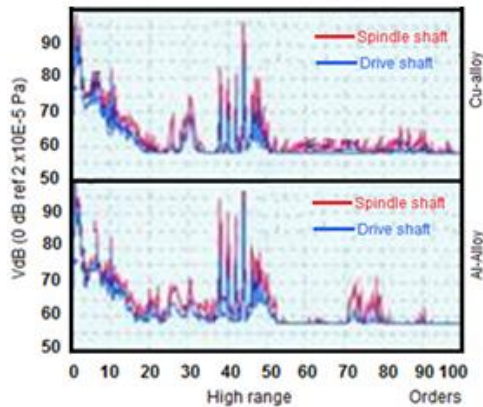

Figure 14: Vibration frequency curves of gear box containing cast iron gears.

The measured highest values of 85 and 84 VdB vibrations were, respectively, with gear box comprising of Nylon-66/Al₂O₃ nanocomposite gears while turning Cu-alloy and Al-alloy rods respectively at spindle speed of 135 rpm (figure 15). The measured lowest values of 82 and 80 VdB vibrations were, respectively, with gear box comprising of Nylon-66/Al₂O₃ nano composite gears while turning steel, Cu-alloy and Al-alloy rods respectively at spindle speed of 1062 rpm. As per IRD General Machinery Vibration Severity Chart, these conditions [7] are **Very Smooth** (79 < VdB < 85). The measured highest values of 97 and 94 dB noises were, respectively, produced while turning Cu-alloy and Al-alloy rods respectively at spindle speed of 1062 rpm with gear box comprising of Nylon-66/Al₂O₃ nanocomposite gears. These values are within the permissible noise limit (108 dB) for the machines [8]. The low values of vibration might be owing to internal damping characteristics of nanocomposites. Rajoria and Jalili hypothesized using a stick-slip model that the enhancement in the damping capacity can be due to the poor adhesion between the nanotubes and the polymer matrix and they predicted an enhancement in the damping capacity if well alignment and well dispersion are achieved [11]. Buldum and Lu also studied the interfacial sliding and the rolling motion of carbon nanotubes on a graphite surface using molecular dynamics. They observed that nanotube sticks and then slips suddenly under a sufficient load exerted on it and that the barrier of the potential energy for the sliding motion is higher than that of a perfect rolling motion [12].

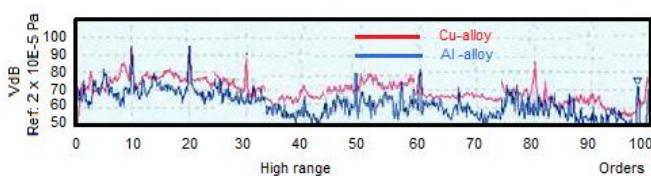

Figure 15: Vibration frequency curves of gear box containing Nylon-66/Al₂O₃ nanocomposite gears at spindle shaft.

6. Conclusions

The vibrations and noise have been significantly reduced by replacing the cast iron gears with Nylon-66/Al₂O₃ nano composite gears in the gear box to 85 VdB and noise 97dB, respectively under dry operating conditions. As per IRD General Machinery Vibration Severity Chart, the condition of the lathe is **Very Smooth**. The noise levels are within the permissible noise limit for the machines. The nylon-66 gear box is suitable only for soft metals like non-ferrous materials.

7. Acknowledgement

The author is thankful to All India Council for Science and Technology (AICTE), New Delhi for sponsoring this project. The File No. is 8023/RID/RPS-2011-12 dated: 02.12.2011.

References

- [1] M. Akerblom. "Gear Noise and Vibration – A Literature Survey," TRITA-MMK 2001:11 / ISSN 1400-1179 / ISRN/KTH/MMK/R-01/11-SE, Stockholm 2001.
- [2] D. B. Welbourn. "Fundamental Knowledge of Gear Noise – A Survey" Proceedings IMechE Vibrations in Transmissions Systems Conference, The Institution of Mechanical Engineers, Cranfield, UK, July 1979, pp. 9–14.
- [3] R.F. Gibson and A. Yau, "Complex moduli of chopped fiber and continuous fiber composites: comparison of measurements with estimated bounds," Journal of Composite Materials, 14 (1980) 155–67.
- [4] McLean D, Read BE. Storage and loss moduli in discontinuous composites. Journal of Material Science, 10 (1975) 481–92.
- [5] A. Chennakesava Reddy and M. Vidya Sagar "Two-dimensional theoretical modeling of anisotropic wear in carbon/epoxy FRP composites: comparison with experimental data," International Journal of Theoretical and Applied Mechanics, vol.6, no.1, pp. 47-57, 2010.
- [6] Karan Agarwal, Nirmala Akhil, Regalla Srinivas and A. Chennakesava Reddy, "Enhancement in Mechanical Behavior of Nylon/Teflon Composites by Addition of Nano Iron Oxide (γ -Fe₂O₃)," International Journal of Science and Research, vol.5, no.5, pp.927-932, 2015.
- [7] The IRD General machinery Vibration Severity Chart, Entek IRD International, pp.1-25, <https://rockwellautomation.custhelp.com>.
- [8] Noise measurement Manual, Prepared by: Environmental Performance and Coordination Branch, Department of Environment and Heritage Protection, The State of Queensland, 2013.
- [9] K. Kohler and R. Regan, "The Derivation of Gear Transmission Error from Pitch Error Records," vol.61, The Institution of Mechanical Engineers, 1985.
- [10] A. Flodin, "Wear of Spur and Helical Gears" Royal Institute of Technology, Stockholm, Doctoral Thesis, 2000.
- [11] H. Rajoria and N. Jalili, "Passive vibration damping enhancement using carbon nanotube-epoxy reinforced composites," Composite Science and Technology, vol.65, pp.2079-2093, 2005.
- [12] A. Buldum and J.P. Lu, "Atomic scale sliding and rolling of carbon nanotubes," Physics Reviews Letters, vol.83, pp.5050–5053, 1999.