

Automatous Security Defender Using PIC Microcontroller and GSM Module PEP-ARMOR

Komal Jain¹, Mahesh Kumar²

^{1,2}Department of Electronics and Communication Engineering, Galgotias College of Engineering & Technology, Greater Noida .India

Abstract: *With the frequent evolutionary changes occurring in the emerging world due to the advancement in technology and research, the ultimate aim of every individual is self-security and safety of belongings. Especially if we talk about women, kids and elderly people who are under serious threat of heinous crimes. This paper focuses on the basic idea underlying the device which is to flash a warning about the distressed victim to the police so that the incident could be prevented and the culprit apprehended. In emergency situation on a single trigger the device will get activated and will perform multiple actions simultaneously implemented to avoid the unwanted condition. When triggered the device will perform multiple functions simultaneously in order to avail more chances to escape the situation. The device includes GSM module, Camera module with high power flash light, panic alarm and deterrent along with many other equipment to support the device mounted on solder board. This paper summarizes some of the important work in the field of personal safety and hence focuses on our device.*

Keywords: PIC microcontroller, one-trigger, help, emergency, GSM module, PEP-ARMOR

1. Introduction

Today India is emerging as one of largest superpower in the world but we cannot ignore the very fact of our society is under serious threat from unethical incidents of harassments, molestation and violent attacks faced every now and then. A large sector of our society including women, girls, kids and senior citizens have less physical strength to fight back an unwanted and unavoidable emergency situation and as a result they are targeted at most. May it be sexual harassment, physical violence, rape or more general cases of everyday kidnapping, robbery or mugging. It happens on streets, public transport and parks, in and around schools and workplaces, in public sanitation facilities and water and food distribution sites, or in their own neighborhoods. In India, according to the National Crime Records Bureau's (NCRB) 2005 Crime Clock, there is one crime committed against women every three minutes, one molestation case every 15 minutes; one sexual harassment case every 53 minutes, one kidnapping and abduction case every 23 minutes and one rape case every 29 minutes are reported. [1] Urgent action needs to be taken in order to escape such situations. One way solution to this is to inculcate the technological advancements in the field of safety devices. Such atrocities can be bought to an end through our project. Our device is named "PEP-ARMOR" that is 'pepper shield' which is an attempt in order to put a step forward to avoid such conditions. The basic approach is to intimidate about the unethical act and hence a distress message is sent to the cops and registered number, so that unfortunate incidents would be averted. Also a video is sent to provide real time evidence for swift action against the perpetrators of crime against women.[2]

This is a single trigger device which gets activated as soon as the victim feels an emergency situation and presses the button. As the button is triggered PEP-ARMOR starts performing the multiple functions. As the user would press the push-button device will release the pepper deterrent, thereby triggering the Camera Module to make video of the

crime scene. LED flashes at the same time. Immediately thereafter, the video is being displayed at the device attached to the camera receiver attached to some output device. Along with this the GSM module sends message to 2 numbers. This one-trigger device works on the PIC microcontroller. The panic alarm activation helps to avail the nearest possible help and deterrent makes the attacker inactive. Major reason for the increase in rape statistics is the nonexistence of a suitable surveillance system to ensure the safety.[1] Currently the work is under process to miniaturize it so that it could be embedded in jewelries, mobile phones etc. in order to make it a versatile instrument for masses.[2]

PEP-ARMOR is a microcontroller based device. It is used as a defense gadget in which on advent of any sort of danger, the user can trigger the Pepper spray manually releasing the deterrent and dodging the attacker.

Once the pepper spray is blown, the microcontroller gets activated. In turn, a Siren which is connected with the microcontroller starts ringing in order to alert the nearby surroundings. Also, a bright flashlight is turned on. (For the times, the attack is in evening-night). We have also attached a wireless camera to the project which live telecasts the whole scenario at a TV placed far by. Basically it has following parts-

- Power Supply
- PIC 16f88
- DC Motor
- Wireless Camera
- Flashlight
- Buzzer
- GSM Modem

In this project we show that how we monitor WOMEN SECURITY with alarm and one emergency message is transferred to the person automatically. At the same time all the supply system is also off. GSM modem is serially

connected to the pin no 10, 11 of the controller. Output of the controller is serially connected to the max232 IC.

Max232 is further connected to the GSM Modem. We store the person number in the program code. Microcontroller sends a predefined message on this number serially to the GSM modem.

2. Existing System

Many devices and applications exist in the market which provides amazing features but they don't perform multiple functions. Wearable and easy-to-operate electronic device exists that will help girls and women to trigger required Communication with family and police when in distress. [3] Some of them are as follows:

2.1 Safety Link

One is supposed to press and hold the Safety LINK button for 3 seconds and friends, family and nearby members of the Safety LINK community & the 24x7 monitoring station is informed.[4]

2.2 Android Application

The android application receives emergency alerts and a picture of the crime suspect over Bluetooth when the pepper spray is triggered. It configures the cell phone's Bluetooth transceiver as a client to Pep Guard. The Received picture is saved on the user cell phone while an emergency call is initiated. [5]

2.3. LifeFone

LifeFone Personal Response Service offers users a 480-foot (146 m) range in any direction with its waterproof pendants, which also come with removable belt or pocket clips for those who don't want to wear the devices as bracelets or necklaces. [6]

2.4. The Guardian Angel

Described by its creators as an "accessory with a purpose," the Guardian Angel can be worn as either a pendant or a bracelet, and works via Bluetooth with an app on your smartphone. The device will go a step further and send an emergency alert, along with your location, to a contact you've pre-programmed.[7]

2.5. Charm Alarm

There's also the anti-theft-focused Charm Alarm, which is a connected necklace that keeps tabs on your purse and wallet. It warns you if you walk too far away from your belongings or if someone tries to grab your bag and walk away. It also makes noise to attract attention to the theft.[8]

2.6 Amrita Personal Safety System (APSS)

A new technology to protect women from potential rapists

and sexual offenders. APSS is an inconspicuous, wearable and easy-to-operate electronic device that will help women in establishing communication with family and police at the first sign of trouble. The device will remain invisible to the criminals and yet can easily be triggered by the user with multiple options, to ensure steady and secure communication. This customizable device is integrated with over 15 features pertaining to safety and security of women and other potential victims. [3]

3. Proposed

We are glad to propose a system which incorporates many of the above features in a single device. Basic motive is to design a single trigger system which can perform multiple functions simultaneously. This device will empower the user to start communication with family and police when in need yet can be easily triggered by the victim with multiple options to ensure stealthy and secure communication. With the ability to record conversations, and communicate immediately by the press of a button or using SOS .This device also offers automated information on nearest police station and family to get immediate help. The device is also to video tape events [3]. Following are the main features of the device:

3.1 One Trigger –Multiple Functions

PIC microcontroller is used in order to design a system which can perform all the below defined actions at one push-button trigger.PIC microcontrollers (Programmable Interface Controllers), are electronic circuits that can be programmed to carry out a vast range of tasks. [7]

3.2 SOS Message

GSM module is connected to PIC microcontroller so that as soon as the device is triggered, text message is sent to the two preconfigured numbers (Primary number: Police station; Secondary number: Family)

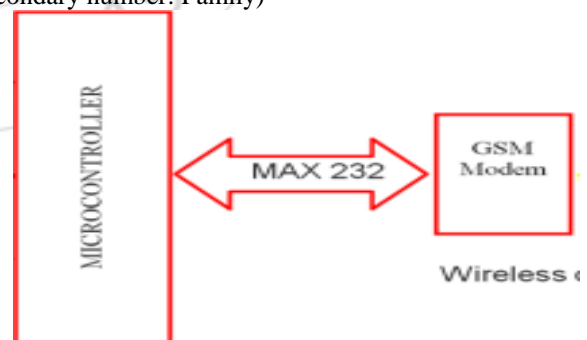

3.3 Camera Recording

Camera starts recording the ongoing scene and the video is saved to the SD card and can be retrieved later. Also video is sent to the receiver which has been attached to the monitoring device from where the output can be processed for investigation also the video of crime scene can be seen live.

3.4 Panic Alarm

The first need is to inform the nearby people who can reach for help. Due to the panic situation one might not be able to scream in such a case this panic alarm is a high pitch alarm which helps to escape the distress situation.

3.5 Pepper Spray

The manual triggering of pepper spray lets the deterrent to come out subsequently dodging the attacker.. Pepper spray is used to help subdue and arrest dangerous, combative, violent, or uncooperative subjects in a wide variety of scenarios.

4. Design Concept

This is the block diagram of PEP-ARMOR.

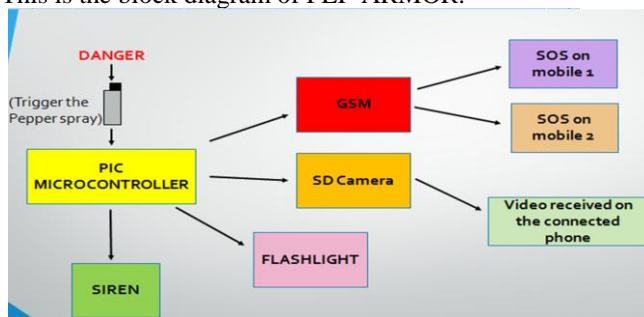

Figure 1: Autonomous self-safety device

5. Circuit and Construction

5.1 Overview

In this paper we have implemented women safety system on PIC microcontroller via GSM modem and camera module and the interfacing is done through MAX-RS 232. Small introduction of these modules which were used in proposed work are discussed below

5.1.1 PIC microcontroller

The PIC16F887 is one of the latest products from Microchip. It features all the components which modern microcontrollers normally have. For its low price, wide range of application, high quality and easy availability, it is an ideal solution in applications such as: the control of different processes in industry, machine control devices, measurement of different values etc

5.1.2 GSM Modem

GSM modem is serially connected to the pin no 10, 11 of the controller. Output of the controller is serially connected to the max232 IC. Max232 is further connected to the GSM Modem. We store the person mobile number in the program code. Microcontroller sends a predefined message on this number serially to the GSM modem.

5.1.3 MAX-232

The max232 IC is used to convert TTL/CMOS logic levels to RS232 logic levels during serial communication of microcontrollers with pc. The controller operates at TTL logic level (0-5v) whereas the serial communication in PC

works on RS232 standards (-25v to + 25v) this makes it difficult to establish a direct link between them to communicate with each other. [9]

5.2 Circuit

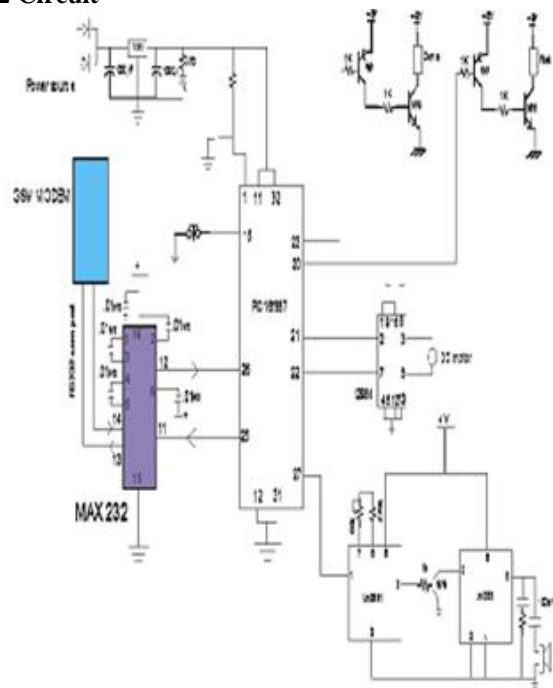

6. Conclusion

In the original project we have combined the best possible hardware /software features to develop a device which performs following functions:

- Once the device is triggered, pepper spray is blown and the camera starts recording the ongoing scene.
- Simultaneously an alarm starts ringing and the flash light turns on.
- SOS message is being sent to two preconfigured numbers.

It can be concluded by saying such a system can revolutionize the present scenario of women safety. It will make the women safe and secure in our public places. [1] It is of great importance that most of our objectives have been met .And more efforts are being made to instantly send the video so as the make the device more effective. We really believe that this endeavor will make a difference in the life of many and dream about seeing this world with individuals walking fearlessly.[2]

7. Experimental Results

We have successfully implemented the system and acquired the desired output. The intelligent security system women has been developed with such a motivation that the women are provide with safe environment under all circumstances. [1]This device ensures that in case of emergency as soon as the device is triggered it gets activated. The one touch starts the camera which records the video of ongoing scene and displays the same on the device connected to receiver placed back at home. The panic alarm also starts at trigger. Also single trigger the pepper spray comes out of the device.

References

- [1] Remya George, Anjaly Cherian.V, “An Intelligent Security System for Violence against Women in Public Places” International Journal of Engineering and Advanced Technology (IJEAT) ISSN: 2249 – 8958, Volume-3, Issue-4, April 2014
- [2] Nishant Bhardwaj “Design and Development of “Suraksha”-A Women Safety Device” International Journal of Information & Computation Technology. ISSN 0974-2239 Volume 4, Number 8 (2014), pp. 787-792
- [3] <http://www.amritapuri.org/16788/apps.aum>
- [4] <https://www.indiegogo.com/projects/safetylink-safety-for-everybody-everywhere>
- [5] John Yin (zy93), Cordelia Lee (cr165) Design with Microcontrollers “An Augmented Pepper-spray with Camera and Emergency Response” http://people.ece.cornell.edu/land/courses/ece4760/FinalProjects/f2012/zy93_cr165_lt277/Final_Report.pdf
- [6] <https://www.lifefone.com/http://www.livescience.com/43016-best-medical-alert-systems.html>
- [7] <http://www.verizonwireless.com/news/article/2014/10/6-emergency-wearables-for-women.html>
- [8] <http://www.technologystudent.com/pics/picgen1.html>
- [9] Design of women safety system using RFID, 8051 microcontroller and GSM based technology a prototype Shaik Mazhar Hussain1 , Shaik Jhani Bhasha

Author Profile



Komal Jain is currently pursuing her B.Tech (2011-2015) from Galgotias College Of Engineering & technology in Electronics and communication Engineering stream.



Mahesh Kumar is currently pursuing his B.Tech (2011-2015) from Galgotias College of Engineering & technology in Electronics and communication Engineering stream.