

Implementation of Automated Door Accessing System with Face Design and Recognition

Shrikrishna Jogdand¹, Mahesh Karanjkar²

¹Department of Electronics and Telecommunication, Shree Tuljabhavani College of Engineering, Tuljapur, Osmanabad, India

²Professor, Department of Electronics and Telecommunication, Shree Tuljabhavani College of Engineering, Tuljapur, Osmanabad, India

Abstract: Most doors are controlled by persons with the use of keys, security cards, password or pattern to open the door. The aim of this paper is to help users for improvement of the door security of sensitive locations by using face detection and recognition. Face is a complex multidimensional structure and needs good computing techniques for detection and recognition. This paper is comprised mainly of three subsystems: namely face detection, face recognition and automatic door access control. Face detection is the process of detecting the region of face in an image. The face is detected by using the Viola Jones method and face recognition is implemented by using the Principal Component Analysis (PCA). Face Recognition based on PCA is generally referred to as the use of Eigenfaces. If a face is recognized, it is known, else it is unknown. The door will open automatically for the known person due to the command of the microcontroller. On the other hand, alarm will ring for the unknown person. Since PCA reduces the dimensions of face images without losing important features, facial images for many persons can be stored in the database. Although many training images are used, computational efficiency cannot be decreased significantly. Therefore, face recognition using PCA can be more useful for door security system than other face recognition schemes.

Keywords: Viola-Jones Face Detection Method, PCA, Eigenvector, Covariance, Euclidean, Distance, Eigenface, Microcontroller

1. Introduction

Nowadays, automatic personal identification in access control has become popular by using biometrics data instead of using cards, passwords or pattern. Most of the biometrics data have to be collected by using special hardware such as fingerprint scanner, palm print scanner, DNA analyzer. And, the target objects have to touch with the required hardware in the stage of data collection. The advantage of this system is that face recognition does not require to be touched with any hard-ware. Face is detected automatically by using face detection technique and the entire face recognition is completed without touching with any hardware. Face detection is the first step of the face recognition system. The performance of the entire face recognition system is influenced by the reliability of the face detection. By using face detection, it can identify only the facial part of an image regardless of the background of this image. In this system, Viola-Jones face detection method is used. Viola-Jones rescale the detector instead of the input image and run the detector many times through the image each time with a different size.

Viola-Jones have devised a scale invariant detector that requires the same number of calculations whatever the size. This detector is constructed using a so-called integral image and some simple rectangular features reminiscent of Haar wavelets [1]. Face recognition commonly includes feature extraction, feature reduction and recognition or classification. PCA is an effective feature extraction method based on face as a global feature. It reduces the dimension of images effectively and holds the primary information at the same time. In this paper, face recognition system is implemented using PCA algorithm. Recognition or classification is done by the measure method such as Euclidean distance, which is used to classify the feature of images present in the database and test image.

In this system, face detection and recognition are implemented by using MATLAB installed on PC. USB to RS232 converter is used as the interface between the PC and 16F887 microcontroller. Edge sensors are used to switch off the motor if the door reaches one of its two end positions. This switching mainly works with an algorithm which is loaded in microcontroller and on the basis of serial port data which is sent by PC after verifying the face. The overall block diagram of this system is shown in figure 1.

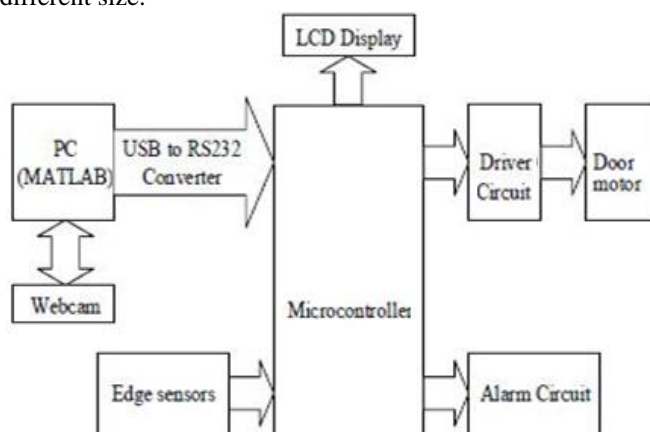

Figure 1: block diagram of automatic door access system using face recognition

2. Methodology

A. Facial Recognition System

Steps in the facial recognition process. Let us for the moment assume that we have a probe image with which to work. The facial recognition process normally has four interrelated phases or steps.

- 1)The first step is face detection.
- 2)The second is normalization.
- 3)The third is feature extraction.
- 4)The final cumulative step is face recognition.

These steps depend on each other and often use similar

techniques. They may also be described as separate components of a typical FRS. Nevertheless, it is useful to keep them conceptually separate for the purposes of clarity. Each of these steps poses very significant challenges to the successful operation of a FRS.

B. Feature Extraction and Recognition

Once the face image has been normalized, the feature extraction and recognition of the face can take place. In feature extraction, a mathematical representation called a biometric template or biometric reference is generated, which is stored in the database and will form the basis of any recognition task. Facial recognition algorithms differ in the way they translate or transfer m a face image (represented at this point as grayscale pixels) into a simplified mathematical representation (the features) in order to perform the recognition task (algorithms will be discussed below). It is important for successful recognition that maximal information is retained in this transformation process so that the biometric template is sufficiently distinctive.

C. Face-recognition module

The Face-recognition module is based on PCA based on Eigen faces and it is programmed using MATLAB/Open CV. It is executed in a PC/FPGA which can be chosen depending on the need or the environment where the system is implemented. The PCA algorithm based on Eigen faces is explained in the figure 6. Principal component analysis transforms a set of data obtained from possibly correlated variables into a set of values of uncorrelated variables called principal components. The number of components can be less than or equal to the number of original variables.

The first principal component has the highest possible variance, and each of the succeeding components has the highest possible variance under the restriction that it has to be orthogonal to the previous component. We want to find the principal components, in this case eigenvectors of the covariance matrix of facial images. The set of images that are stored in the database are taken as the training set. These set of images are the pictures of the people for whom the access should be granted. From this training set, the mean is calculated and subtracted to get the average vectors from

Which we can get our covariance matrix and hence the Eigen vectors which are the Eigen faces, E.

3. Conclusion

In this paper, face recognition system has been developed in order to study the potential application for automated door access control. Among the other bio-metric techniques, face recognition approach posses one great advantage which is user friendliness. The technique of Eigen faces has been applied into the system which makes the system more secure. A cost effective and SMS operated home security system has been designed and tested with the GSM network. As future efforts, improving the reliability and robustness in both the recognition and detection process can be concentrated more.

References

- [1] John See and Sze-Wei Lee, An Integrated Vision-based Architecture for Home Security System, IEEE Transactions on Consumer Electronics, Vol. 53, pp: 489-498, No. 2, May 2007.
- [2] Y.-K. Choi, K.-M. Kim, J.-W. Jung, S.-Y. Chun, and K.-S. Park, Acoustic intruder detection system for home security, IEEE Trans. Consumer Elec-tron., vol. 51, no. 1, pp: 130-138, Feb. 2005.
- [3] F. Zuo, and P. H. N. de With, Real-time embedded face recognition for smart home, IEEE Trans. Consumer Electron., vol. 51, no. 1, pp.183-190, Feb. 2005.
- [4] I. Kramberger, M. Grasic, and T. Rotovnik, Door Phone Embedded System for Voice Based User Identification and Verification Platform, IEEE Transactions on Consumer Electronics, Vol. 57, No. 3, pp:1212-1217, August 2011
- [5] Ratnawati Ibrahim and Zalhan Mohd Zin, Study of Automated Face Recognition System for Office Door Access Control Application, IEEE 3rd Conference on Communication Software and Networks, Pg no:132-136, May 2011.
- [6] Manivannan M., and Kumaresan N., Design of On-line Interactive Data Acquisition and Control System for Embedded Real Time Applications Proceedings of ICETECT 2011.
- [7] Il-Kyu Hwang, Member, IEEE and Jin-Wook Baek, Wireless Access Monitoring and Control System based on Digital Door Lock, IEEE Transactions on Consumer Electronics, Vol. 53, No. 4, pp:1724-1730, Nov 2007.

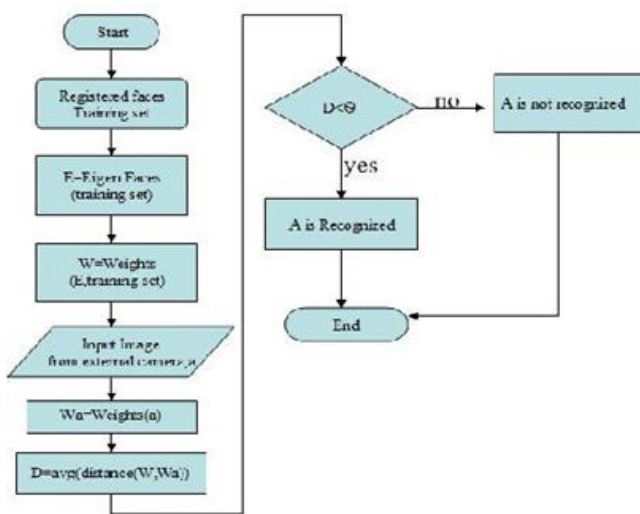

Figure 2: Face-recognition module