

Simulation Study of the Unified Power Flow Controller (UPFC)

Mahendra Pratap Singh Gurjar¹, Girish Dalal²

¹M.Tech scholar Department of Electrical Engineering, Mewar University, Chittorgarh, Rajasthan, India

²Assistant Professor, Department of electrical Engineering, Mewar University, Chittorgarh, Rajasthan, India

Abstract: The focus of this thesis is a FACTS device known as the Unified Power Flow Controller (UPFC). We study the simulation model of UPFC and its output. We also study about the buck-boost converter Simulink model and its output. We study the controller design of Unified Power Flow Controller design.

Keywords: Simulation, unified power controller, power, steady-state, dynamic and linearized

1. Introduction

The power system is an interconnection of generating units to load centers through high voltage electric transmission lines and in general is mechanically controlled. It can be divided into three subsystems: generation, transmission and distribution subsystems. Until recently all three subsystems were under supervision of one body within a certain geographical area providing power at regulated rates. In order to provide cheaper electricity the deregulation of power system, which will produce separate generation, transmission and distribution companies, is already being performed. At the same time electric power demand continues to grow and also building of the new generating units and transmission circuits is becoming more difficult because of economic and environmental reasons. Therefore, power utilities are forced to rely on utilization of existing generating units and to load existing transmission lines close to their thermal limits. However, stability has to be maintained at all times. Hence, in order to operate power system effectively, without reduction in the system security and quality of supply, even in the case of contingency conditions such as loss of transmission lines and/or generating units, which occur frequently, and will most probably occur at a higher frequency under deregulation, a new control strategies need to be implemented.

2. UPFC Basic Operation and Characteristics

2.1 Basics of Voltage Source Converters and Pulse Width Modulation Technique

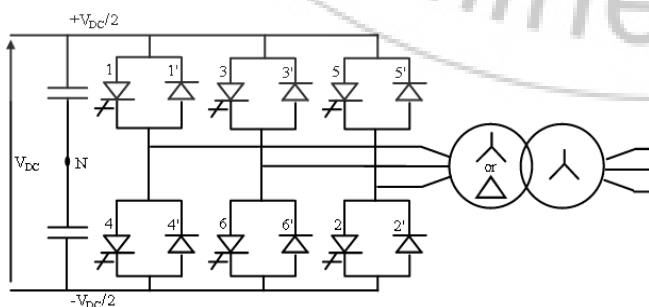

Figure 2.1: Three-phase voltage sourced-converter

It is made of six valves each consisting of a gate turn off device (GTO) paralleled with a reverse diode, and a DC capacitor. An AC voltage is generated from a DC voltage through sequential switching of the GTOs. The DC voltage is unipolar and the DC current can flow in either direction.

In this case $v_r > v_c$ results in a turn on signal for the device one and gate turn off signal for the device four and $v_r < v_c$ results in a turn off signal for the device one and gate turn on signal for the device four.

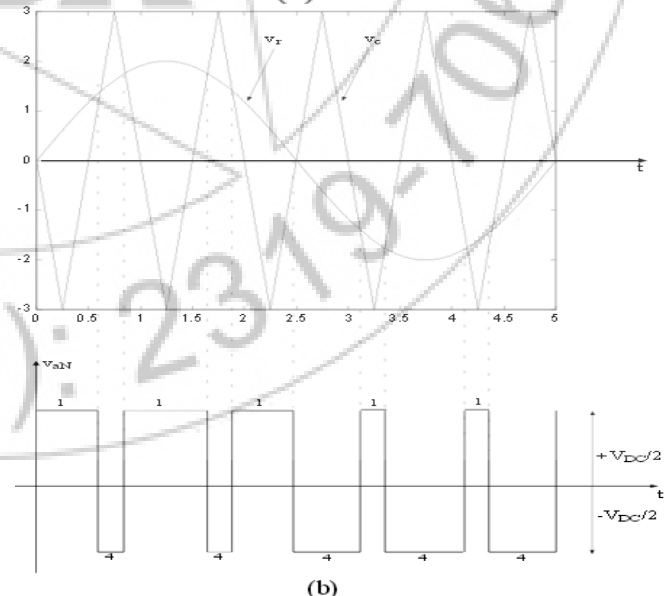
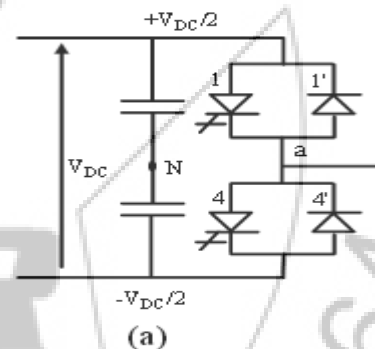

Figure 2.2: PWM converter (a) A phase-leg (b) PWM waveforms

3. UPFC Modeling and Interfacing

3.1 UPFC Load Flow (LF) Model

For steady-state operation, the DC link voltage remains constant at its pre-specified value. In the case of a lossless DC link the real power supplied to the shunt converter satisfies the real power demanded by the series converter. The LF model discussed here assumes that the UPFC is operated to keep (i) real and reactive power flows at the receiving bus and (ii) sending bus voltage magnitude at their pre-specified values. In this case UPFC can be replaced by an “equivalent generator” at the sending bus (PV-type bus using load flow terminology) and a “load” at the receiving bus (PQ-type bus) as shown in Fig. 3.1. To obtain the LF solution for the power network with the UPFC an iterative procedure is needed. Power demanded at the receiving bus is set to the desired real and reactive powers at that bus. The real power injected into a PV bus for conventional LF algorithm is kept constant and the reactive power is adjusted in order to achieve the pre-specified voltage magnitude. With UPFC, the real power injected into the sending bus is not known exactly. This real power injection is initialized to the value that equals the pre-specified real power flow at the receiving bus. During the iterative procedure the real power adjustment is done in order to cover the losses of the shunt and series impedances and to force the sum of converters' interaction to become zero.

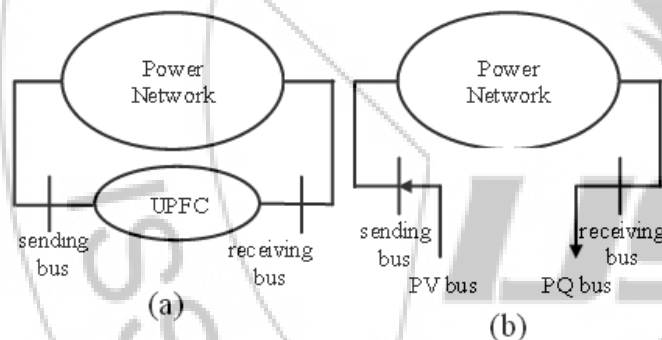

Figure 3.1: Power network with a UPFC included (a) schematic (b) Load Flow Model

3.2 Load flow algorithm

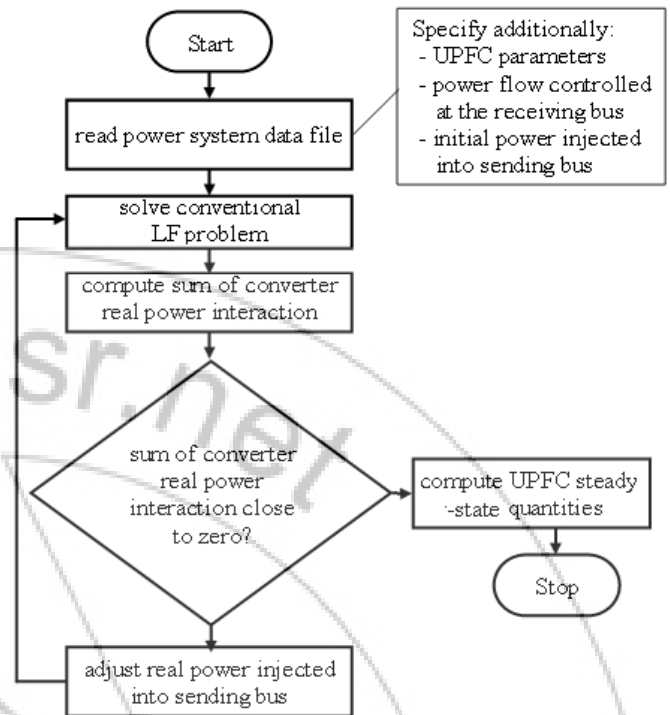

Figure 3.2: Load flow algorithm

3.3 Linearized Model

The linearized model of the power network including UPFC will be derived in this section. This model can be used for small signal analysis and damping controller design.

3.3.1 Basic Terms and Definitions

The state space representation of the linear continuous time system is given by

$$\dot{x}(t) = Ax(t) + Bu(t)$$

$$y(t) = Cx(t) + Du(t)$$

Where:

- $x(t)$ is the state of the system at time t
- $u(t)$ is the control input at time t
- $y(t)$ is the output of the system at time t
- A is the $n \times n$ plant matrix
- B is the $n \times m_u$ input matrix
- C is the $m_y \times n$ output matrix
- D is the $m_y \times m_u$ feed forward matrix

4. Controller Design

To operate the UPFC in the automatic control mode discussed in the third chapter, and also to use the UPFC to enhance power system stability and damp low frequency oscillations, two control designs need to be performed. A primary control design, referred to as the UPFC basic control design, involves simultaneous control of (i) real and reactive power flow on the transmission line, (ii) sending bus voltage magnitude, and (iii) DC voltage magnitude. A secondary control design, referred to as the damping controller design, is a supplementary control loop that is designed to improve

transient stability of the entire electric power system. The two control designs are described in this.

advantage of fuzzy control design is that mathematical model of the system is not required.

4.1 Basic Control

4.1.1 Series Control Scheme

This scheme has two control loops, one for the tracking of the real power flow at the receiving bus of the line, and the second performs the same task for the reactive power flow.

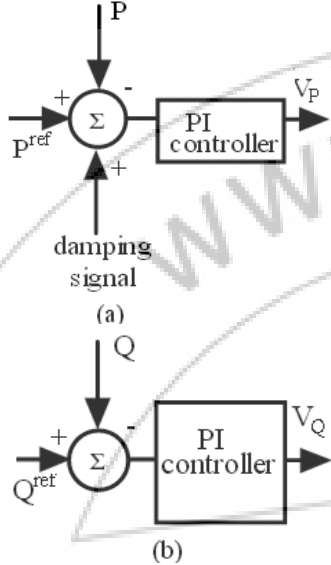

Figure 4.1: Series control scheme-automatic power flow mode

4.1.2 Shunt control scheme:-

This control scheme also has two loops that are designed to maintain the magnitude of the sending bus voltage and the DC link voltage at their pre-specified values.

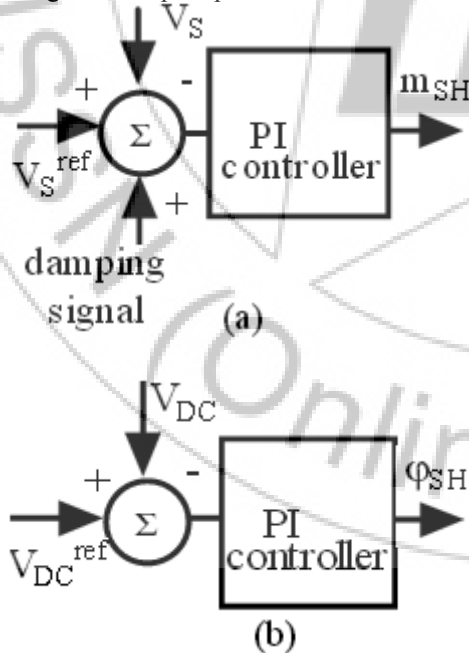

Figure 4.2: Shunt control scheme

4.2 Damping Controller Design

Fuzzy control is based on fuzzy logic theory. There is no systematic design procedure in fuzzy control. The important

4.2.1 Fuzzy Logic UPFC Damping Controller

Input signals to the controller, power flow deviation from the steady-state value ΔP and its integral ΔE , are derived from the real power flow signal at the UPFC site.



Figure 4.3: Obtaining the input signals for fuzzy controller

5. Simulation Model and Results

5.1 Buck-Boost Converter

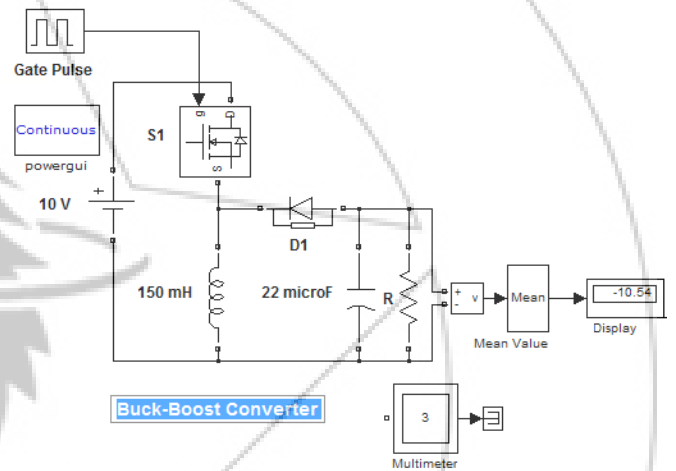

Figure 5.1: Buck- boost converter simulation model

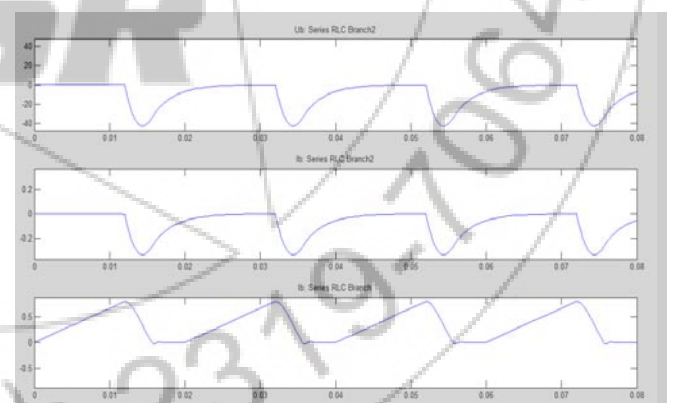

Figure 5.2: output of buck-boost converter.

5.2 The Unified Power Flow Controller (UPFC)

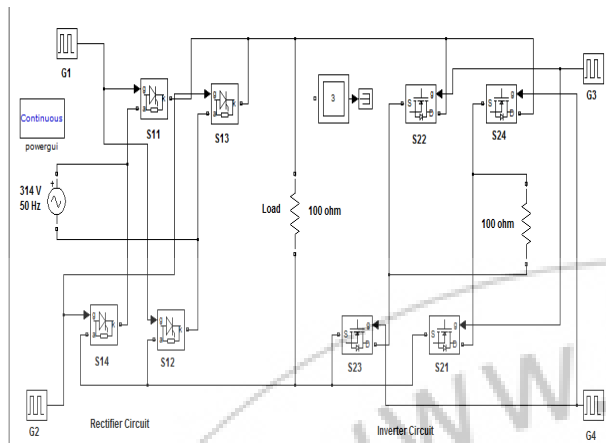

Figure 5.3: Simulation model of single phase dual converter.

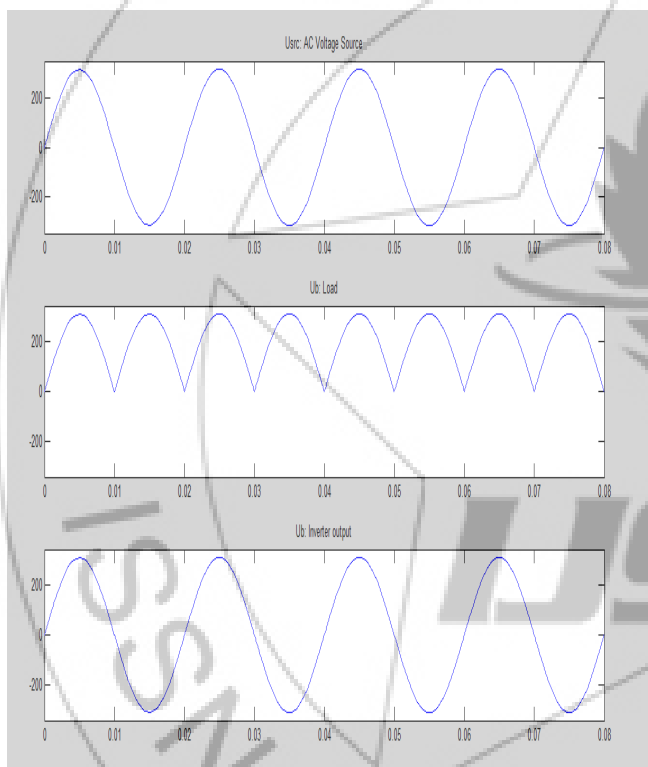

Figure 5.4: Output of single phase dual converter

6. Conclusion

This thesis deals with the FACTS device known as the Unified Power Flow Controller that is used to maintain and improve power system operation and stability. It presents UPFC steady-state, dynamic and linearized models, algorithm for interfacing the UPFC with the power network and UPFC basic and damping controller design. We successfully study the simulation model of UPFC and its output. We also study about the buck-boost converter Simulink model and its output.

References

- [1] Anderson, P. M., Fouad, A.A., Power System Control and Stability, Iowa State University Press, 1977

- [2] Kundur, P., Power System stability and Control, McGraw-Hill Inc., 1994
- [3] Hingorani, N.G, Gyugyi, L., Understanding FACTS Devices, IEEE Press 2000
- [4] Hingorani, N.G., 'Flexible AC Transmission', IEEE Spectrum, April 1993, p. 40-44
- [5] Gyugyi, L., 'Dynamic Compensation of AC Transmission Lines by Solid-state Synchronous Voltage Sources', IEEE, 1993, p. 904-911
- [6] Edris, A. Mehraban, A.S., Rahman, M., Gyugyi, L., Arabi, S., Rietman, T., 'Controlling the Flow of Real and Reactive Power', IEEE Computer Application in Power, January 1998, p. 20-25
- [7] Gyugyi, L., 'A Unified Power Flow Control Concept for Flexible AC Transmission Systems', IEE Proceedings-C, Vol. 139, No. 4, July 1992, p. 323-331
- [8] Gyugyi, L., Schauder, C.D., Williams, S.L., Rietman, T.R., Torgerson, D.R., Edris, A., 'The Unified Power Flow Controller: A New Approach to Power Transmission Control', IEEE Transactions on Power Delivery, Vol. 10, No. 2, April 1995

Author Profile



Mahendra Pratap Singh Gurjar is M.Tech scholar, Department of Electrical Engineering, Mewar University, Chittorgarh, Rajasthan, India

Girish Dalal, Assistant Professor, Department of electrical Engineering, Mewar University, Chittorgarh, Rajasthan, India