

Real-Time Industrial Parameter Measurement Using CAN, Zigbee and Ethernet Web Server

Kavitha. B. C¹, Gopakumar S²

¹Assistant Professor Department of Electronics and Communication Engineering Hindustan University, Chennai, India

²MTech Embedded systems Department of Electronics and Communication Engineering Hindustan University, Chennai, India

Abstract: *The demand of energy is increased day by day so we have to save the energy for our future generation. To reduce the energy consumption of various equipment running in industry, Real-Time Industrial Parameter Measurement Using CAN, Zigbee and Ethernet Web Server plays a key role. This paper presents various methods to measure and record the parameters of equipments running in an industry. Here Power consumption, Temperature, speed of rotation and voltage are the parameters. After monitoring the parameters data will send to gateway section using CAN protocol. Gateway section is connected to the web server using wireless Zigbee. User can access the each and every machine using IP. The purpose of temperature sensor is to control the equipment based on the threshold level. If the machine is having high temperature it will be turned off automatically and if the temperature is below the level it will be turned on.*

Keywords: Microcontroller, Temperature, Zigbee, speed of rotation Energy consumption, Controller Area Network (CAN)

1. Introduction

Latest microcontrollers are used in industrial automation to controls various equipment running in an industry and to reduce the manual work. The type of latest technologies will reduce the erratic reading, real-time, data processing, increasing the accuracy. This type of technologies is user friendly. Wire based meter reading systems is having lots of drawbacks, are more complex and to maintain the system is not that much easy. Wired installation is also have lots of problems damage will occur very easily. So due to these reasons most of the industry will choose automatically monitor the parameters. In this paper, it will describe how to measure different parameters. Machines are controlled on these parameters. The different parameters are send to the microcontroller in the monitoring section. The data will process and send to the Ethernet web server section using CAN and Zigbee protocol. In web server section PC is connected to the Ethernet controller using RJ45 connector. User can access each and every machine using the IP. Each machine unit is having one LCD display to display the current temperature and the power consumption. Based on the temperature machine will turned on (<500 C) and turned off (>500 C). The paper is organized as follows: in Section II the related work, are investigated and studied for mitigation of Wireless networks. Section III is devoted to system architecture. In section IV we show the software implementation of system. The demonstration of the system is described in section V followed by some concluding remarks in section VI

2. Related Work

In this section, we briefly discuss the existing system about Energy consumption DAQ system for Industries based on wireless communication technology. K.Gill et al [1]

proposed ZigBee based home automation system can control and monitor home appliances. The proposed system consists of a home network device and a home gateway supports interoperability between external networks.

Kadu Rahul N et al [2] proposed a remote wireless Automatic meter Reading System based on ARM9 and Zigbee Technology for Short distance Zigbee transmission can be achieved with high accuracy and reliability. The system presented has many significant excellences such as networked, wireless, moveable, low power consuming, high accuracy. Stability and accuracy of wireless transmission was improved by the help of embedded system. The proposed system has a broad application foreground in the real application field to remotely measure and manage electric power. The system is simpler, integrated, anti-interference, stronger mobility and practicability. It has many important advantages such as low cost, low power Consumption, reduction in cables. The system dedicates to automatic meter data collection and energy auditing and management.

Liting Cao et al [3] was proposed a networked remote meter-reading system based on Bluetooth wireless communication technology and GSM. The remote meter-reading system employs distributed structure, which consists of measure meters, sensors, intelligent terminals, management center and wireless communication network. The intelligent terminal which designed based on embedded system and Bluetooth technology is used to realize acquisition information submitted from meters and sensors control the energy-consuming devices moreover in residence. The message communicated between the intelligent terminal and management center by dint of GSM network. The structure and function of this meter-reading system are described and the system's hardware and

software detailed. The meter-reading task can be finished at the management center of residence area by using this system. The system has many significant excellences, such as wireless, low-workload, great quantity of data transmission, high-veracity and low-expenses. The using of embedded system improves the stability of wireless data transmission. The remote meter-reading system which can be propitious to administer energy-source and continuous development have abroad application foreground

J. Han et al [4] Proposed home energy management system for to control the various device in home area and to reduce the power consumption. Room is having a Zigbee hub, light and standby power cut-off outlets. The zigbee hub is having IR code learning function and it will control the devices via IR signal. A standby power is available to avoid the electricity failure. During that time stand-by power will use. We turn off the home device to eliminate the waiting time, and the power outlet simultaneously with an IR remote control through the ZigBee hub. It will reduce the standby power. The proposed HEMS provide easy way to delete, add, and move home devices to other power outlets. The proposed HEMS provide easy way to add, delete, and move home devices to other power outlets. The energy information of the home device is kept consistently when a home device is moved to the different outlet, without location change.

3. Existing System

- A. Phone Based Remote Controller for Meter Reading and Automation Phone based remote controller for meter reading and automation. The system differs in that all communications occur over a fixed telephone line and not over the Internet. The system can be accessed using any telephone that supports dual tone multiple frequency (DTMF). The disadvantages of this system are threefold: users are not provided with a graphical user interface, users have to remember an access code, and they have to remember which buttons to press for the control of connected devices in the industry.
- B. Bluetooth Based Automation System for Meter Reading and Controlling Devices. In this technology a primary controller and a number of Bluetooth sub-controllers are used. Each device in home is physically connected to a local Bluetooth sub-controlling device. Through wired communication home devices communicate with their respective sub-controller. By wireless communication data will send from the sub-controller to the primary controller. In this system each devices in home have a dedicated Bluetooth module. In this type of architecture reduce the wired installation. Disadvantage of this system is sharing of a single Bluetooth module between numerous devices causes an access delay.

4. System Architecture

A. Overview of the Proposed System

Proposed system is having three main sections viz, monitoring unit, and gateway unit and web server section. Sensors are connected to microcontroller in monitoring unit. Various parameters are sensed and processed in microcontroller and it will send to the second section via CAN bus. Gate way unit is having connectivity to Zigbee transceiver via UART. Data from the monitor section will send to the web server section through this zigbee. User can access the machines very easily using IP. The purpose of temperature sensor is to control the machines. A particular temperature value will be set in the program and if the temperature value of machine will exceed then it will automatically turned OFF. When the temperature value is below the level it will turned ON automatically.

B. Data Collecting Unit

Data collection unit is having various types of sensors like current sensor, voltage sensor, temperature sensor, shaft encoder, LCD display and a relay circuit. The energy meter count sensor will trigger for each rotation and if the count =760, then it will be equal to one unit. Temperature sensor will read the current temperature value and the machine is controlled accordingly with that temperature value. All sensor reading will send to the gateway using CAN protocol. The gateway is connected to the Ethernet web server section via wireless Zigbee protocol. Using the IP user can access each and every machine. Here PIC 18F4480 is used in monitoring section and separate CAN transceiver (MCP 2551) is used for transmission and reception of data from CAN bus. LCD display is used to display all parameters locally.

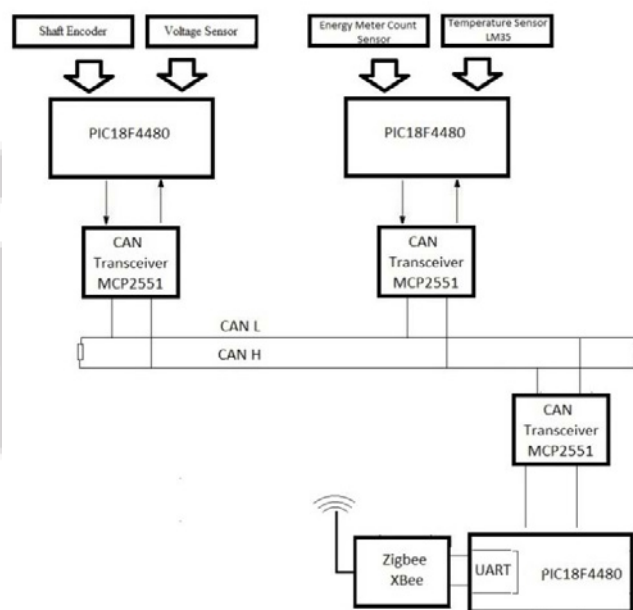

Figure 1: Data collecting unit of the System

C. Ethernet Web Server Section

Ethernet web server section contains Ethernet controller (ENC 28J60), RJ45 and PIC18f6722. Ethernet web server section receives and process the data from the Gateway section via wireless Zigbee protocol. User can access each and every machine using IP. RJ45 is used as a connector between PC and Ethernet controller.

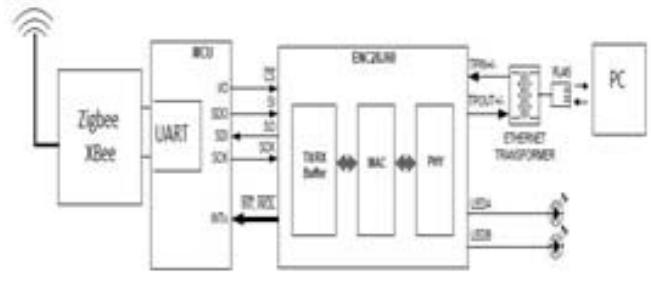

Figure 2: Ethernet web server Section

D. Voltage Monitoring

Step - down transformer is used to transform 220V ac voltage to lower 6V ac. The output of the transformer is fed to the transformation unit which will convert to 5V range. It consists of resistive divider network, zener diode and diode 1N4007.

$$V_{out} = V_{in} * (6/220)$$

E. Temperature Sensor

For monitoring temperature LM 35 is used. The LM35 series are precision integrated-circuit temperature sensors, whose output voltage is linearly proportional to the Celsius (Centigrade) temperature. The LM35 is rated to operate over a -55° to +150°C temperature range. For each 10 C it will give 10mV.

F. Speed Monitoring

Speed of rotation can be calculated by shaft encoder. Shaft encoder is a rotational transducer which converts the angular movement into digital impulses.

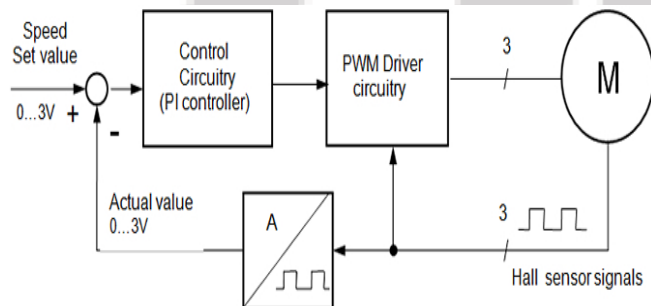

Figure 3: Shaft Encoder diagram

F. UART

UART consists of three main blocks.

- Transmit shift register
- Receive shift register
- Status register

The basic structure of a UART is shown in Fig-4. Any given UART circuit will have three core sections. A Transmit shift register will serialize a datum with appended Start and Stop bits to be shuffled out via a TX pin. Associated with TXREG is a Buffer register holding data for onward transmission. A Status register will hold a flag (TBUF in our diagram) indicating when this buffer is free for more data. The Receive shift register strips the Start and Stop bits off an incoming frame at a RX pin, transferring the parallelized datum when complete into one or more Buffer registers. At the same time, a flag (RBUF in our case) will be set to allow the software to determine that a new datum is ready for collection. This needs to be read before the next frame has been assembled, otherwise an overrun condition will occur and data will be lost. The transmission and reception of a frame is not locked in step; that is, they can overlap, but the baud rates are usually the same

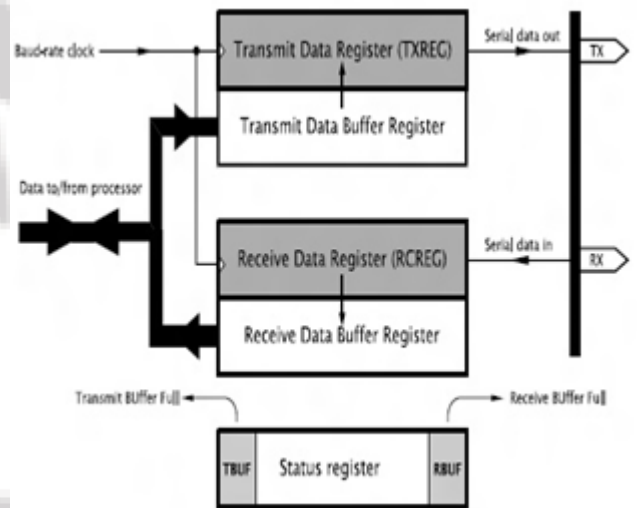

Figure 4: UART block diagram

E. Microcontroller

A microcontroller is a small integrated single chip computer that contains a processor core, memory and programmable in/out peripherals. Program memory is included in the form of OTP ROM or NOR flash. And also contain small amount of RAM.

Microcontrollers are designed for embedded applications such as implantable medical devices, office machines automobile engine control systems, remote controls, power tools and other embedded systems. Microcontroller will reduce the cost of production because of the inbuilt memory I/O etc. So it can able to control more than one devices and process with minimum amount of time. To integrate analog components for controlling non-digital electronic systems mixed signal microcontrollers are used. Some

microcontrollers operate at clock rate frequencies as low as 4 kHz and use 4-bit words for low power consumption here the microcontroller is used for activating and controlling various elements of the automatic distribution system. Two types of microcontrollers are used here PIC18F6722 and PIC18F4480. PIC18F6722 is used in the transmitting section. That means for collecting the power consumption and current temperature reading will be fed to this microcontroller from there it will transmit to the receiver side through Zigbee.

F. CAN Interface

The Controller Area Network (CAN) is a serial bus communications protocol developed by Bosch in the early 1980s. In the early days of the automotive industry, various actuators and electromechanical subsystems are controlled by localized stand-alone controllers. By using CAN protocol networking of electronics in vehicle is more feasible. So from a central point ECU (engine control unit) can control all process. This will help the modularity, increasing functionality and troubleshooting more efficient. In early days CAN development was mainly used for vehicle industry, but now days CAN implemented in almost areas such as medical application, industrial automation, building automation and production machinery. CAN offers an more efficient simple, reliable, and high performance communication protocol between actuators, sensors, controllers, and other nodes in real-time applications. CAN is bus topology based communication protocol, and only two wires are needed for communication over a CAN bus. Only one device can able to send or receive the data because of the multi-master structure, and all other devices will be in listening state. If more than one devices attempt to send data at a time, the higher priority devices is selected to send its data and other devices will be receiving mode.

G. ZigBee Technology

ZigBee technology is a bi-directional wireless communication technology of low power, low cost and low complexity of wireless communication technology. It is used in the application of home automation, Building automation, industrial control and industrial areas of logistics. It is responsible for receiving and transferring data. It is selected around the world as the energy management and efficiency technology of choice in terms of reliably and timing.

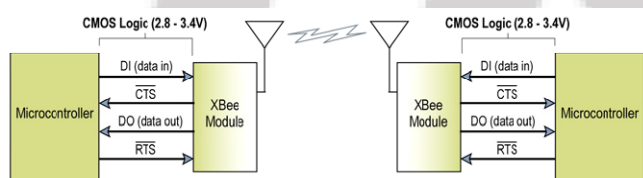

Figure 5: UART data flow

H. Ethernet Controller

The ENC28J60 is a stand-alone Ethernet controller with an industry standard Serial Peripheral Interface (SPI™). It is designed to serve as an Ethernet network interface for any

controller equipped with SPI. The ENC28J60 meets all of the IEEE 802.3 specifications. It incorporates a number of packet filtering schemes to limit incoming packets. It also provides an internal DMA module for fast data throughput and hardware assisted IP checksum calculations. Communication with the host controller is implemented via two interrupt pins and the SPI, with data rates of up to 10 Mb/s. Two dedicated pins are used for LED link and network activity. With the ENC28J60, two pulse transformers and a few passive components are all that is required to connect a microcontroller to a 10Mbps Ethernet network

5. Software Design Implementation

A. TCP/IP Implementation

Different collections of modules are available in our stack, such as IP, TCP, UDP and ICMP. When a corresponding packet is received some modules must be called. If an application utilize the stack, certain steps will perform to ensure that the modules are called at the appropriate times. This purpose of managing stack modules remains the same. The special application layer module "StackTask", or the Stack Manager is used in TCP/IP Stack, to protect the main application from the burden of managing the individual modules. This module is implemented by the source file "StackTsk.c". It is implemented as a cooperative task; during given processing time, "StackTask.c" polls the MAC layer for valid data packets. When one data packet is received, packet will decodes and routes it to the appropriate module for further processing.

B. Web Server

This module is an IP enabled device. If a public IP provided to this module it can easily accessed through the internet. Here an eight bit microcontroller is used, so it would not able to serve more number of request from the public domain. Also any intruder want to break the system, they will make more number of request to this module. So the module cannot handle the requests machine, the essence of a Web server is inevitable.

6. Experimental Demonstration

The system is designed to monitor various parameters and control the equipment running in an industry. For energy consumption monitoring disk type watt hour meter is used. A small hole will be made in the disk of energy meter and two IR sensors are placed both side of the hole, so for each rotation the sensor will trigger. That value will fed to the input of the microcontroller. For temperature monitoring LM35 is used. For our demonstration one 100W incandescent lamp and one electric motor is used. Shaft encoder, electric motor and voltage sensor are connected to the 1st monitoring unit. 100W bulb, temperature sensor and energy meter count sensor connected to the second monitoring unit. Both sensor reading will send to the gateway section via CAN bus. In monitoring section PIC18F4480 is used, this microcontroller is having inbuilt CAN so a separate CAN transceiver is connected to it. All

parameters will display in local LCD display. Data from the gate way section will send to the user's PC via Ethernet controller ENC28J60. User can access each and every machine and control using IP. Wireless Zigbee protocol is used to connect the gateway section and the Ethernet web server section. In Ethernet web server section PIC 18F6722 is used for data processing, UART is used to connect the Zigbee to PIC. Based on temperature and conditions, the switch will be opened automatically to cut OFF the input power supply of machines.

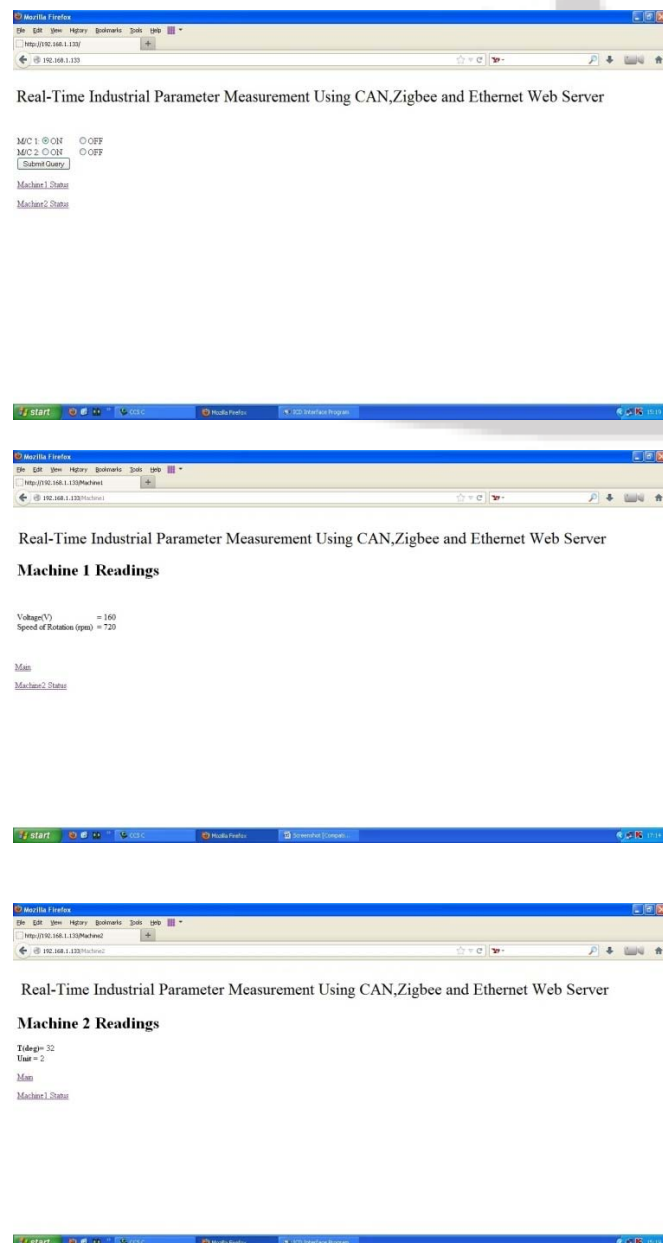

7. Conclusion

In this paper we develop the Real-Time Industrial Parameter Measurement Using CAN, Zigbee and Ethernet Web Server to monitor and to controls various equipment running in an industry. It is designed on the basis of low power consumption, high performance. Various protocols like low power Zigbee protocol, CAN protocol and Ethernet protocols are used in this design. For automatic reading and

processing the data Zigbee technology is used, which uses wireless communication and computer network technologies for these operations. This design will save human work and also improve the speed and accuracy of energy consumption and temperature readings. Moreover no cabling is required with relatively economical investment. For the Real-Time Industrial Parameter Measurement Using CAN, Zigbee and Ethernet Web Server will offer better scalability compared to a wired system. Based on temperature conditions the machine will automatically shut down and will run when the temperature will reach the below threshold.

8. Future Enhancement

Based on the above results, the authors recommend some techniques for the future development.

- Provide strong cryptographic algorithm to avoid the intruders.
- Need further development in parameter monitoring.
- For improving wireless communication we can use Pro-Zigbee module.

References

- [1] K.Gill, S.H. Yang, F. Yao, and X. Lu, "A ZigBee based home automation system," IEEE Trans. Consumer Electron., vol. 55, no. 2, pp 422-430, May 2009.
- [2] Kadu Rahul N., Prof. Shaikh S.A., Prof. Turakne S.S., Prof. Taware S.S., Prof. Aher V.A."An embedded electric meter based on ARM9 and zigbee technology" IJCTEE Volume 2, Issue 3, June 2012
- [3] Liting Cao, Jingwen Tian and Dahang Zhang, "Networked Remote Meter-Reading System Based on Wireless Communication Technology" in International Conference on Information Acquisition, 2006
- [4] J.Han, C.S.Choi, and I. Lee, "More efficient home energy management system based on ZigBee communication and infrared remotecontrols," IEEE Trans. Consumer Electron., vol 57, no. 1, pp. 85-89, Feb, 2011
- [5] Changsu Suh, Young-Bae Ko, "Design and implementation of intelligent home control Systems based on active sensor networks," IEEE Trans. Consumer Electron., vol.54, no. 3, pp.1177-1184, Aug.2008
- [6] Chih-Hung Wu; Shun-Chien Chang; Yu-Wei Huang; "Design of a wireless ARM-based automatic meter reading and control system" in Power Engineering Society General Meeting, 2004.
- [7] C.Landi, G. Ianniello, D. Gallo, M.Luiso "An advanced energy/power meter based on ARM Microcontroller for smart grid applications", 17th Symp. IMEKO TC 4, 3rd Symp. IMEKO TC 19 and 15th IWADC Work.; Instr. for the ICT Era; Sept. 8-10, 2010, Kosice, Slovakia
- [8] D.Gallo, C.Landi, N.Rignano, "Multifunction DSP based real-time power quality analyzer" XVIII IMEKO World Congress Metr. For sust. Devel.. Sept., 17-22, 2006. Rio de Janeiro, Brazil

Author Profile

Kavitha. B. C obtained her B. Tech degree in Electronics and Communication Engineering from Cochin University of Science and Technology in the year 2000 and ME degree in Communication Systems from Hindustan College of Engineering, Anna University in 2007. Currently she is associated with Hindustan University as Assistant Professor. She has a total of 10 years teaching experience and her field of interest includes sensor networks and optical communication

Gopakumar S obtained his M. Sc degree in Applied Electronics from Bharathiar University, Tamilnadu, India in 2011 and he currently pursuing M. Tech Embedded System in Hindustan University, Chennai, Tamilnadu. His field of interest includes Networking and Embedded systems.



IJSR