

Design of Remote Video Monitoring and Motion Detection System based on Arm-Linux Platform and HTTP Protocol with SMS Capability

A. Suresh¹, K. S. R Murthy²

¹M.E Student, Department of ECE, M.V.S.R. Engineering College, Nadergul, Andhra Pradesh, India

²Professor, Department of ECE, M.V.S.R. Engineering College, Nadergul, Andhra Pradesh, India

Abstract: In this paper, a solution about the design of remote video monitoring system based on Arm-Linux platform and http protocol is introduced. And the embedded system, video capture, motion detection, short message service (SMS) alarm, and client video monitor are introduced. Video 4 Linux is used to get the camera video data, which is transferred to the Web Server, and the data is displayed on the client browser. The system can also be connected with mobile phones, using SMS to control alarm equipment. The system can be applied all kinds of video surveillance systems. Compared with video capture system based on digital signal processor (DSP), this system has the advantages of fewer modules, lower cost, higher intelligence, higher system stability, and higher security.

Keywords: video-capture; motion detection; short message service; video4linux, HTTP

1. Introduction

With the development of Broad Band, computer networks, and image processing technology, video capture has been widely used in image acquisition, security, health care, intelligent community, alarm, transportation and so on. But it also has many problems, such as high cost, low intelligence, poor stability, weak security. In order to solve these problems, S3C2440 [1], microprocessor is adopted in this embedded video acquisition system, which combining with the Linux operating system. Video capture is realized by the Video 4 Linux [2]. The Linux kernel provides programming interfaces and data interface functions API for a variety of devices. And it has the advantages of strong network function, system stability, and high safety. The SMS alarm and control function enable the system to the broader development prospects

2. Structure of Video Capture Based on Embedded Linux

The structure of this system is shown in Figure 1. It mainly includes video capture module, S3C2440 microprocessor, memory, LCD, Ethernet interfaces and mobile phone module. The system of processor adopts Samsung's S3C2440A, which integrates the ARM's ARM920T processor. USB controller in S3C2440 provides support for USB devices, which including a USB Host and 1 USB Slave B-type interface. FLASH and 64M SDRAM store data is adopted in the system. It is equipped with a 3.5-inch TFT LCD. Vimicro ZC301P chip camera is adopted in camera system. RS232 interface is adopted for software debugging. Mobile Module is used to control field devices and alarm messaging, etc. Figure 1

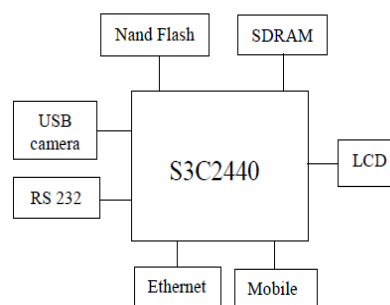

Figure 1: Diagram of the system structure

2.1 Design of Video Capture Hardware

Video capture system is mainly based on the S32C2440 microprocessor, which is connected with the SDRAM, NAND Flash, DM9000 network card, camera, and GPIO port to construct a hardware platform that can support the embedded Linux operating system and network. Besides, the USB camera based on the ZC0301 chip of the company named VMICRO. For the Linux version with 2.6.16 kernel or above, the driver of the cameras is called GSPCA. And this system will select Linux with the 2.6.37 kernel. So, the driver for the camera can be implemented by burning the zImage file which is generated by compiling the kernel with the program of GSPCA into the NAND Flash.

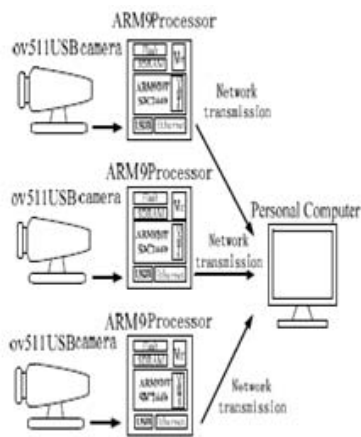

Figure 2: Structure of video capture system

2.2 Video Data Collection

V4L2 is a set of specifications for Linux kernel to develop the drivers of audio and video capture devices, which provide a clear model and uniform interface of API for the driver's development. Meanwhile, it is mainly used to do some operations to the video equipments such as setup, collection, close and other operations. When the system of the server connects a USB camera after transplanting the camera drivers, the system that is Linux will generate a device file node automatically under the directory: /dev/video0. Then, it is easy to access and operate the video device just like an ordinary file. Video data acquisition program is shown in Figure 3.

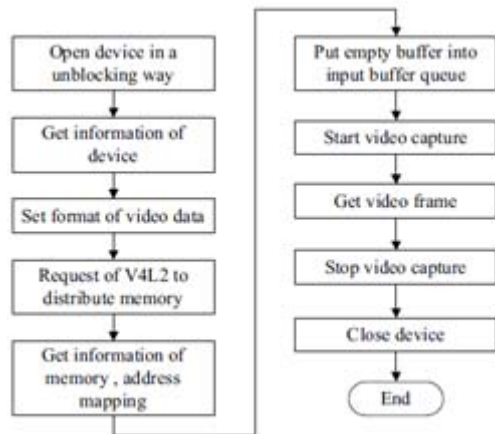

Figure 3: video acquisition program

2.3 Video Compression

Video data compression is adopted to mpeg-4 coding compressed standard. In video monitoring system, a large amount of data realized transmission through network, in order to guarantee the quality and the transmission real-time, we need encoded compression before transmission in order to reduce the amount of data.

3. Design of Network Transmission

In this system, server-side network transmission program uses multiple threads to send real-time video data stream to different clients. Through the listening port that is binding

after building the socket, server can be able to communicate with each client. When the server detects a client's requests to get the connection between them, it will open up a sub-thread to encapsulate the video data and then send the data packages to the client. In an addition, the main thread will continue to monitor the port to accept other clients' requests. Data transmission is based on the http protocol. When the main thread that runs the server program accepts the request of one client, it may create a child thread. At this moment, one connection could be established after the three handshakes between the server and the client. From then on, the server can respond the client's requests (GET method) through the child thread. After receiving and interpreting a message of one request, the server will return some kinds of messages, for example, status message, header of message and other response messages of http. If the response is successful, then the server will continue to send the video data stored in the data buffer by the server push approach. When the client is disconnected or the server closes the connection and stops sending data, the server may kill the child thread and recycle the resources [3] that the connection consumes.

4. Design of Video Monitoring Client

Video monitoring client programs are written by QT in this system. As far as we known, QT has the advantages such as cross-platform, good encapsulation, and it also can be able to compile and run anywhere. Besides, it not only supports most popular operating system platforms such as Windows, Linux, Mac and others, but also supports a lot of embedded operating systems such as Windows CE / Mobile, Symbian, Maemo, Android, etc. QT client of this system uses multi-threaded approach. The GUI thread is the main thread which may create a dedicated thread that will handle the task to receive and decode the video data stream from the network, so it will ensure real-time response of the graphical user interface. When someone clicks the connection button which is the trigger signal that the function associated with slot will create one socket with the server, it will establish a connection with the server-side by the handshakes formula. Then, the client will send the header of the request message and create a dedicated thread to communicate with the server if the last process is successful. At last, the client just needs to wait for the server's response and then get ready to receive the video stream data.

5. Motion Detection

Motion detection is the process of detecting a change in position of an object relative to its surroundings or the change in the surroundings relative to an object. In motion detection previous image compared with present image i. e here comparison of pixels of two images in this comparison if there is no difference indicates nothing is present, then we see green color, if any difference is present indicates something is present then we see the green color on system.

6. SMS Alarm and Control

The system integrates SMS alarm and monitoring components, and makes the mobile phone to bind to it. When alarm signal is detected by the system, it will notice

the user of the mobile phone in the form of text messages. Then the user sends text messages to control and manage the abnormal event. The SMS completes the SMS alarm and data transmission, remotely monitoring and controlling equipment through Global System for Mobile Communications (GSM) of wireless communication modules. GSM is an abbreviation of global system for mobile communications, and GSM has the function of a wireless communications [5]. In general, many phones have a GSM network module. It is associated with the operating system through a serial port, supporting GSM07.07 of the AT commands and using the AT instructions to realize SMS transceiver, alarm and query. It is the most mature mobile communication system. In this system, when video abnormal changes or exceeds the threshold of setting appears, the camera will automatically capture the new image data and send it to the PC, and the PC will transport an abnormal information of "discover a new image" to server-side mobile phone in the system through the serial port, then this cell phone will convert the information into a format of text messages so as to sent to the user mobile phone. System structure is shown in Figure 4:

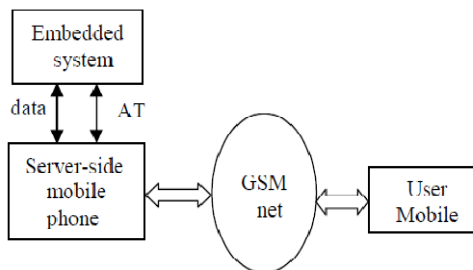

Figure 4: User mobile phone. System structure

It is need to use the SMS protocol description unit (PDU) encoding and serial communication class libraries for communication between systems and mobile phones, and the realization of SMS receiving and sending requires AT commands. The AT commands list is shown in Table 1[4]

Table 1: AT commands list

AT Commands	Function Notes
AT+CMGD	Delete SMS Message
AT+CMGF	Set SMS format
AT+CMGL	List all SMS
AT+CMGR	Receive SMS Commands
AT+MGS	Send a SMS command
AT+CMGW	Write a text message and store the command
AT+CSCA	Set SMS centre command
AT+CSMP	Set Text Mode Parameter
AT+CSMS	Set SMS service
AT+ CSDH	Display the current text mode
AT+ CNMA	The new SMS confirm
AT+ CNMI	Set a new way of SMS Tips
AT+ CMSS	Send text message from
AT+ CPMS	Select SMS Memory

In order to realize SMS alarm, it is necessary to use the AT command to design SMS sending and receiving procedures, including protocol data and SMS text. SMS can realize remote monitoring .When the system is abnormal; it can inform the mobile phone in no time.

7. Result

Connect the board to network using Ethernet cable using RJ45 connector. Now at client side open the web browser and type the following IP address in address bar.

7.1 Video Monitoring

10.0.0.80:8080/video_capture.html, now we can see the following output on the browser on the client side. We can see the video at the development board.

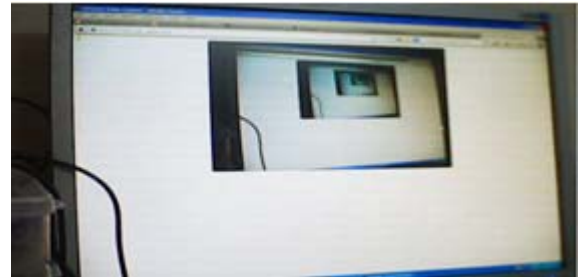

Figure 5: video monitoring

7.2 Motion detection

In this system, previous image always compared with the present image. Now type command 10.0.0.80:8080/motion_detection.html



Figure 6: No object is present (indicates green colour)



Figure 7: Some object is present(indicates green color)

8. Conclusion

The structure of video capture system based on S3C2440 processor is presented. And the embedded system, video capture, short message service (SMS) alarm, and client video monitor are introduced. Video 4 Linux is used to get the camera video data, which is transferred to the Web

Server, and the data is displayed on the client browser or on client. The system can also be connected with mobile phones, using SMS to control alarm equipment. The system can be applied in intelligent anti-theft, intelligent transportation, intelligent home, medical treatment, as well as all kinds of video surveillance systems. Compared with video capture system based on digital signal processor (DSP), this system has the advantages of fewer modules, lower cost, higher intelligence, higher system stability, and higher security.

References

- [1] Samsung Electronics S3C2440X 32- BIT RISC Microprocessor User's Manual.Revision1.2.Publication
- [2] QingXuanCai,YinSongPan.The USB-based embedded VIDEO4LINUXvideo signal acquisition. Electronic Design and Application, 2009, (02) pp.40-42.
- [3] LIU Sheng, ZHAO Jingjing, FAN Xiuli. The Embedded Video Surveillance System Based on V4L2[J].Microcomputerapplications.2011,32(1):37-42
- [4] YanGuang Yang. Embedded system and mobile phone text messagesexchange.Application of Electronic technology, 2006, (05).pp.61-62.
- [5] XiaoChenYuan,YipingPan,Jianqing LI. An SMS-based IntelligentControl System Design and Implementation. The computer age, 2007, (12). Pp.55-56.