

Implementation of an Advanced Soft-Start Induction Motor System with Integrated IoT-Based Monitoring Technique: A Comprehensive Review

Minakshi Ratnakarrao Kalambe¹

¹PG Scholar, Department of Electrical Engineering, Wainganga College of Engineering & Management, Nagpur, India

Dr. D.R. Tutakne

Supervisor, Assistant Professor, Department of Electrical Engineering, Wainganga College of Engineering & Management, Nagpur, India

Abstract: *Induction motors are extensively used in industrial and electric vehicle applications due to their robustness, cost-effectiveness, and low maintenance requirements. However, their performance is often affected by electrical, mechanical, and environmental faults, leading to reduced efficiency and unexpected failures. This review paper presents a comprehensive analysis of recent advancements in induction motor monitoring, fault diagnosis, and control techniques, with a focus on integrating soft-start mechanisms and Internet of Things (IoT)-based systems. Conventional methods such as Motor Current Signature Analysis (MCSA), vibration analysis, and thermal monitoring are discussed alongside modern approaches including artificial intelligence and data-driven techniques for enhanced fault detection. Furthermore, the role of IoT in enabling real-time monitoring, remote control, and predictive maintenance is critically examined. Recent developments in energy-efficient motor drives and soft-start technologies are also reviewed to highlight their impact on reducing inrush current and improving operational reliability. The study identifies key challenges such as lack of integrated systems and limited real-time decision-making capabilities. Finally, it emphasizes the need for intelligent, IoT-enabled, and energy-efficient solutions to enhance motor performance, reliability, and lifespan in modern industrial environments.*

Keywords: Induction Motor, IoT, Soft Start, Fault Diagnosis, Predictive Maintenance.

1. Introduction

Induction motors are one of the most widely used electrical machines in industrial applications due to their simple construction, ruggedness, high reliability, and low maintenance requirements. They are commonly employed in various applications such as pumps, compressors, conveyors, and electric vehicle systems. Despite their advantages, induction motors are susceptible to different types of faults that can significantly affect their performance and efficiency. These faults are generally classified into electrical, mechanical, and environmental categories. Electrical faults include voltage imbalance, overload, and single phasing, while mechanical faults involve bearing failures, rotor bar breakage, and shaft misalignment. Environmental factors such as temperature, humidity, and vibrations also contribute to motor degradation and failure [1], [5].

To ensure reliable operation, condition monitoring and fault diagnosis of induction motors have become critical areas of research. Traditional methods such as Motor Current Signature Analysis (MCSA), vibration analysis, and thermal monitoring have been widely used for detecting faults. These techniques are effective but often limited by noise sensitivity, complex signal processing requirements, and lack of real-time implementation capabilities [1], [6]. Recent advancements have introduced intelligent and data-driven approaches, including machine learning and artificial intelligence, which provide improved accuracy and early fault detection. These methods utilize large datasets and advanced algorithms to identify fault patterns and predict failures before they occur [6], [9].

In addition to fault detection, improving the efficiency and operational life of induction motors is another important consideration. One of the major challenges in motor operation is the high inrush current during startup, which can cause voltage drops, mechanical stress, and energy losses. To address this issue, soft-start techniques have been developed to gradually increase the motor voltage during startup, thereby reducing electrical and mechanical stresses. Advanced soft-start control methods, including thyristor-based and PWM-based techniques, have shown significant improvements in reducing starting current and enhancing motor performance [8].

With the rapid development of digital technologies, the integration of the Internet of Things (IoT) has revolutionized the monitoring and control of industrial systems. IoT-based systems enable real-time data acquisition, remote monitoring, and intelligent decision-making. By using sensors and communication modules, motor parameters such as voltage, current, temperature, and speed can be continuously monitored and transmitted to cloud platforms for analysis. This allows operators to access data remotely, receive alerts, and take corrective actions promptly, thereby reducing downtime and maintenance costs [3], [7].

Moreover, IoT-based monitoring systems support predictive maintenance strategies, where potential faults are identified before they lead to system failure. This approach significantly improves system reliability and reduces operational costs. In industrial environments, IoT integration also facilitates energy monitoring and optimization, contributing to improved efficiency and sustainability [10]. Recent research has highlighted the importance of combining IoT technologies with advanced control strategies to develop smart and efficient motor systems capable of meeting modern industrial demands [4].

Volume 15 Issue 5, May 2026

Fully Refereed | Open Access | Double Blind Peer Reviewed Journal

www.ijsr.net

Despite these advancements, there is still a lack of integrated solutions that combine soft-start techniques, IoT-based monitoring, and intelligent fault diagnosis into a single system. Most existing studies focus on individual aspects, such as fault detection or remote monitoring, without addressing the need for a unified framework. Therefore, there is a growing need for research that integrates these technologies to enhance the overall performance, reliability, and efficiency of induction motors.

This review paper aims to analyze and synthesize recent developments in induction motor monitoring, fault diagnosis, soft-start control, and IoT integration, providing insights into future research directions for developing intelligent and energy-efficient motor systems.

2. Problem Identification

- Induction motors frequently experience electrical faults such as voltage imbalance, overload, and single phasing, leading to reduced efficiency and unexpected failures.
- Mechanical issues like bearing damage, rotor bar breakage, and shaft misalignment are often not detected at early stages, causing costly breakdowns.
- Existing monitoring systems lack real-time data acquisition and remote accessibility, making it difficult for operators to take timely corrective actions.
- Conventional starting methods result in high inrush current and torque stress, which reduce motor lifespan and increase energy consumption.
- Many systems focus only on parameter monitoring without intelligent control or automatic protection, limiting their effectiveness.
- Lack of integration between soft-start techniques and IoT-based platforms results in inefficient and fragmented motor management systems.
- Absence of predictive maintenance strategies leads to reactive maintenance, increasing downtime and operational costs.
- Limited application of advanced monitoring systems in electric vehicles and smart industrial environments restricts overall system optimization and scalability.

3. Literature Survey

A) Literature Review

1. R. R. Kumar, M. Andriollo, G. Cirrincione (2022), This review presents a comprehensive analysis of conventional and intelligent techniques used for fault diagnosis and condition monitoring of induction motors. The authors discuss traditional methods such as Motor Current Signature Analysis (MCSA), vibration monitoring, and model-based approaches, highlighting their limitations in noisy and dynamic environments. The study further explores advanced data-driven techniques, including machine learning and artificial intelligence, which improve fault detection accuracy and early diagnosis. A key finding is the effectiveness of hybrid approaches that combine physical models with data-driven algorithms to enhance reliability. The paper emphasizes the importance of feature extraction and selection for accurate fault classification and concludes that intelligent monitoring systems are essential for modern industrial applications.

2. R. Issa, G. Clerc, M. H.-C. (2024), This paper reviews fault diagnosis methods specifically applied to induction machines used in railway traction systems. The authors analyze various signal sources such as current, voltage, vibration, and thermal signals for fault detection. They highlight the challenges associated with variable speed operation and inverter-fed drives commonly used in railway applications. The study finds that conventional diagnostic techniques are less effective under fluctuating operating conditions, necessitating adaptive and robust algorithms. Advanced signal processing and AI-based methods are recommended for improving detection accuracy. The review concludes that real-time monitoring and adaptive fault diagnosis techniques are crucial for ensuring safety, reliability, and efficiency in railway traction systems using induction motors.

3. Dawid Witczak, Sabina Szymoniak (2022), This review focuses on monitoring and control systems based on the Internet of Things (IoT). The authors discuss the architecture of IoT systems, including sensors, communication networks, cloud platforms, and user interfaces. They examine various communication protocols and data processing techniques used for real-time monitoring and control. The study highlights the benefits of IoT, such as remote accessibility, real-time data analysis, and improved system efficiency. It also addresses challenges related to data security, scalability, and interoperability. The findings suggest that IoT-based systems are highly effective for predictive maintenance and smart industrial applications. The authors conclude that integrating IoT with automation systems enhances operational efficiency and decision-making capabilities.

4. Mohamed Azab (2024), This review explores recent trends in high-efficiency induction motor drives. The author discusses advancements in motor design, including the use of wide bandgap (WBG) semiconductor devices, improved magnetic materials, and optimized control strategies. The paper highlights energy-efficient drive techniques such as variable frequency drives (VFDs) and regenerative braking systems. It also examines the role of advanced control algorithms in reducing energy losses and improving performance. The study finds that modern induction motor drives significantly enhance efficiency and reduce operational costs. The review concludes that integrating energy-efficient technologies with intelligent control systems is essential for sustainable industrial operations and improved motor performance.

5. Sayedabbas Sobhi, Mohammad Hossein Reshadi, Nick Zarft, Albert Terheide (2022), This paper reviews condition monitoring and fault detection methods for small induction motors. The authors compare model-based, signal-based, and data-driven techniques for detecting faults. They analyze the effectiveness of different sensing methods, including vibration, current, and temperature measurements. The study highlights that low-cost monitoring systems are essential for small-scale applications, but they often face challenges related to accuracy and reliability. Data-driven approaches using machine learning are found to improve fault detection performance. The authors conclude that combining multiple sensing techniques can enhance diagnostic accuracy while

maintaining cost-effectiveness, making such systems suitable for industrial and domestic applications.

6. B. Hafez Bahgat, Enas A. Elhay, Mahmoud M. Elkholy (2024), This review discusses advanced fault detection techniques for three-phase induction motors. The authors examine methods such as Motor Current Signature Analysis (MCSA), partial discharge analysis, and wavelet-based signal processing. They also explore the application of artificial intelligence and machine learning algorithms for fault classification and prediction. The study finds that combining multiple diagnostic techniques improves sensitivity and accuracy in fault detection. The paper emphasizes the importance of early fault detection to prevent severe damage and reduce maintenance costs. The authors conclude that sensor fusion and intelligent algorithms play a vital role in developing reliable and efficient motor monitoring systems.

7. Amol More, Sanaya Kulkarni (2024), This review focuses on IoT-enabled motor monitoring and control systems in industrial environments. The authors discuss the use of sensors, cloud computing, and communication technologies for real-time data acquisition and analysis. The study highlights the integration of IoT with PLC and SCADA systems for improved automation and control. It emphasizes the advantages of remote monitoring, reduced downtime, and enhanced operational efficiency. The findings suggest that IoT-based systems enable predictive maintenance and better resource management. The authors conclude that IoT integration is a key factor in developing smart industrial systems and improving the reliability of motor operations.

8. Asif Hussain, Raja Masood Larik, Muhammad Salman Saeed, Agha Yasir Ali (2024), This review examines soft-start and soft-ramp control techniques for improving the performance of three-phase induction motors. The authors analyze various starting methods, including thyristor-based soft starters, PWM-based controllers, and intelligent control techniques such as neural networks. The study highlights the drawbacks of direct-on-line starting, including high inrush current and mechanical stress. It finds that soft-start techniques significantly reduce starting current, improve efficiency, and extend motor lifespan. The authors conclude that advanced control methods combined with intelligent algorithms can further optimize motor performance and energy consumption.

9. Rajeev Kumar, R. S. Anand (2024), This review presents an analysis of health monitoring and fault analysis techniques for induction motors. The authors discuss common fault types, their causes, and their impact on motor performance. The study evaluates different diagnostic methods, including vibration analysis, thermal monitoring, and current analysis. It emphasizes the importance of automated monitoring systems for early fault detection and preventive maintenance. The findings suggest that integrating advanced monitoring techniques with intelligent systems can significantly reduce downtime and maintenance costs. The authors conclude that predictive maintenance strategies are essential for improving system reliability and operational efficiency.

10. Eckart Uhlmann, Julian Polte, Claudio Geisert (2024), This review focuses on IoT-based energy and production monitoring in industrial systems. The authors analyze the role of IoT in energy consumption tracking, data acquisition, and performance optimization. The study discusses sensor selection, data analytics, and cloud-based monitoring systems. It highlights the importance of real-time data for improving energy efficiency and reducing operational costs. The findings indicate that IoT-enabled systems provide better insights into system performance and enable effective decision-making. The authors conclude that integrating IoT with industrial processes enhances productivity, sustainability, and energy management, making it highly relevant for modern motor monitoring systems.

B) Literature Summary

The reviewed literature highlights significant advancements in induction motor monitoring, fault diagnosis, and control systems. Traditional techniques such as Motor Current Signature Analysis (MCSA), vibration analysis, and thermal monitoring remain widely used for detecting electrical and mechanical faults. However, these methods often face limitations in accuracy and real-time implementation. Recent studies emphasize the adoption of intelligent techniques, including machine learning and artificial intelligence, which improve fault detection accuracy and enable early diagnosis. IoT-based monitoring systems have gained attention for providing real-time data acquisition, remote accessibility, and predictive maintenance capabilities. These systems integrate sensors, cloud platforms, and communication technologies to enhance operational efficiency and reduce downtime. Additionally, advancements in soft-start and energy-efficient motor drives have demonstrated significant improvements in reducing inrush current, minimizing mechanical stress, and optimizing energy consumption. Despite these developments, most studies focus on individual aspects such as monitoring, control, or efficiency improvement rather than a unified solution. Overall, the literature indicates a shift toward intelligent, connected, and energy-efficient motor systems for modern industrial applications.

C) Research Gap

Although extensive research has been conducted on induction motor monitoring and control, several critical gaps remain. Most existing studies address fault detection, IoT-based monitoring, or soft-start techniques independently, lacking a comprehensive integrated system. There is limited research combining real-time IoT monitoring with advanced soft-start mechanisms and intelligent decision-making for improved efficiency and reliability. Current IoT-based systems mainly focus on data visualization and remote access but do not fully utilize predictive analytics or automated fault response mechanisms. Additionally, many fault diagnosis techniques are not adaptable to varying operating conditions such as fluctuating loads and speeds, reducing their effectiveness in real-world applications. Another gap lies in the lack of cost-effective and scalable solutions suitable for both industrial and electric vehicle applications. Furthermore, integration of multiple sensor data for accurate fault prediction is still underexplored. Therefore, there is a strong need for developing a unified, intelligent system that integrates IoT, soft-start control, and

advanced fault diagnosis techniques to enhance performance, reliability, and energy efficiency of induction motors.

4. Research Methodology

A) Criteria for selecting this study:

- 1) The study focuses on induction motors, which are widely used in industrial and electric vehicle applications, making it highly relevant and practical.
- 2) It addresses real-time monitoring and control, which is essential for improving system reliability and reducing unexpected failures.
- 3) The integration of IoT technology enables remote accessibility, data logging, and smart decision-making, aligning with modern industrial trends.
- 4) The use of soft-start techniques helps in reducing inrush current, mechanical stress, and energy losses, enhancing motor lifespan.
- 5) The study emphasizes preventive and predictive maintenance, which minimizes downtime and maintenance costs.
- 6) It combines multiple parameters monitoring such as voltage, current, temperature, and speed for comprehensive analysis.
- 7) The system is designed to be cost-effective and scalable, suitable for both small and large-scale applications.
- 8) It has potential applications in smart industries and electric vehicles, making it future-oriented and innovative.

B) Method of analysis:

- 1) Data Acquisition: Sensors are used to continuously collect motor parameters such as voltage, current, temperature, and speed during operation.
- 2) Signal Processing: The collected analog signals are converted into digital form using a microcontroller (Arduino Uno) for further analysis.
- 3) Real-Time Monitoring: Data is transmitted to a cloud platform through an IoT module for continuous real-time monitoring and visualization.
- 4) Threshold Comparison: Measured parameters are compared with predefined safe limits to detect abnormal operating conditions.
- 5) Fault Detection: Any deviation from standard values is identified as a potential fault, such as overload, overheating, or voltage imbalance.
- 6) Performance Evaluation: Motor performance is analyzed based on efficiency, stability, and response during soft-start operation.
- 7) Control Action Analysis: Automatic and manual control responses are evaluated for effectiveness in preventing damage.
- 8) Data Logging & Interpretation: Historical data stored in the cloud is analyzed to support predictive maintenance and improve system reliability.

C) Comparison and Analysis:

S.No.	Authors / Year	Technique Used	Key Focus Area	Limitations
1	Kumar et al. (2022)	MCSA, AI/ML	Fault diagnosis & condition monitoring	Requires high computational resources and quality data
2	Issa et al. (2024)	Signal processing, AI	Railway traction motor fault detection	Less effective under dynamic load variations
3	Witczak & Szymoniak (2022)	IoT-based systems	Monitoring & remote control	Security and data privacy concerns
4	Azab (2024)	Energy-efficient drives	Efficiency improvement & control	Limited focus on fault detection integration
5	Sobhi et al. (2022)	Sensor-based, ML	Low-cost condition monitoring	Accuracy affected by sensor limitations
6	Bahgat et al. (2024)	Wavelet, AI, MCSA	Advanced fault detection	Complex implementation and high cost
7	More & Kulkarni (2024)	IoT, Cloud, SCADA	Smart industrial monitoring	Lacks intelligent decision-making systems
8	Hussain et al. (2024)	Soft-start, ANN	Starting performance improvement	Not integrated with IoT monitoring
9	Kumar & Anand (2024)	Monitoring techniques	Health monitoring & maintenance	Limited real-time automation
10	Uhlmann et al. (2024)	IoT analytics	Energy monitoring & optimization	Does not address motor fault detection

D) Evaluation of methodologies used in the reviewed studies

- 1) Conventional Techniques (MCSA, Vibration, Thermal): Widely used due to simplicity and low cost; however, they are sensitive to noise and less effective under varying operating conditions.
- 2) Signal Processing Methods: Techniques such as FFT and wavelet transforms improve fault detection accuracy but require complex computations and expert interpretation.
- 3) Artificial Intelligence & Machine Learning: Provide high accuracy in fault classification and early detection; however, they depend on large datasets and high computational power.
- 4) IoT-Based Monitoring Systems: Enable real-time data acquisition, remote monitoring, and cloud storage, enhancing system accessibility and scalability.

- 5) Soft-Start Control Techniques: Methods using thyristors and PWM reduce inrush current and mechanical stress, improving motor lifespan and efficiency.
- 6) Hybrid Approaches: Combining sensor data, AI, and IoT offers improved performance but increases system complexity and implementation cost.
- 7) Limitations Identified: Most methodologies lack integration, real-time intelligent decision-making, and cost-effective implementation for practical industrial applications.

E) Highlighting trends, advancements, and challenges Trends:

- Increasing adoption of IoT-based monitoring systems for real-time data acquisition and remote control of induction motors.
- Shift towards predictive maintenance using data analytics and cloud platforms.

- Growing use of AI and machine learning for accurate fault diagnosis.
- Integration of smart sensors and wireless communication in industrial automation systems.

Advancements:

- Development of advanced soft-start techniques reducing inrush current and improving efficiency.
- Implementation of hybrid monitoring systems combining IoT, AI, and sensor fusion.
- Use of energy-efficient motor drives and modern power electronics technologies.
- Enhanced cloud computing and data visualization tools for better decision-making and performance analysis.

Challenges:

- High implementation cost of advanced monitoring and intelligent control systems.
- Issues related to data security, privacy, and network reliability in IoT platforms.
- Requirement of large datasets and computational power for AI-based methods.
- Lack of integrated and standardized systems suitable for diverse industrial and EV applications.

5. Discussion

A) Synthesis of findings from literature

The reviewed literature collectively indicates that induction motor performance and reliability can be significantly

enhanced through the integration of advanced monitoring, control, and diagnostic techniques. Traditional fault detection methods such as Motor Current Signature Analysis, vibration monitoring, and thermal analysis remain effective for identifying common faults; however, their limitations in dynamic and noisy environments necessitate more robust solutions. Recent studies emphasize the growing importance of artificial intelligence and machine learning techniques, which offer improved accuracy and early fault prediction by analyzing large datasets.

Furthermore, IoT-based systems have emerged as a key trend, enabling real-time monitoring, remote accessibility, and data-driven decision-making. These systems facilitate predictive maintenance, reducing downtime and operational costs. Advances in soft-start techniques and energy-efficient motor drives have also demonstrated significant improvements in reducing inrush current, minimizing mechanical stress, and enhancing overall efficiency.

Despite these advancements, the literature highlights a lack of integrated systems combining IoT, intelligent diagnostics, and soft-start control. Therefore, a unified approach is essential to achieve optimal performance, reliability, and energy efficiency in modern induction motor applications.

B) Methodology for future research directions

Proposed System:

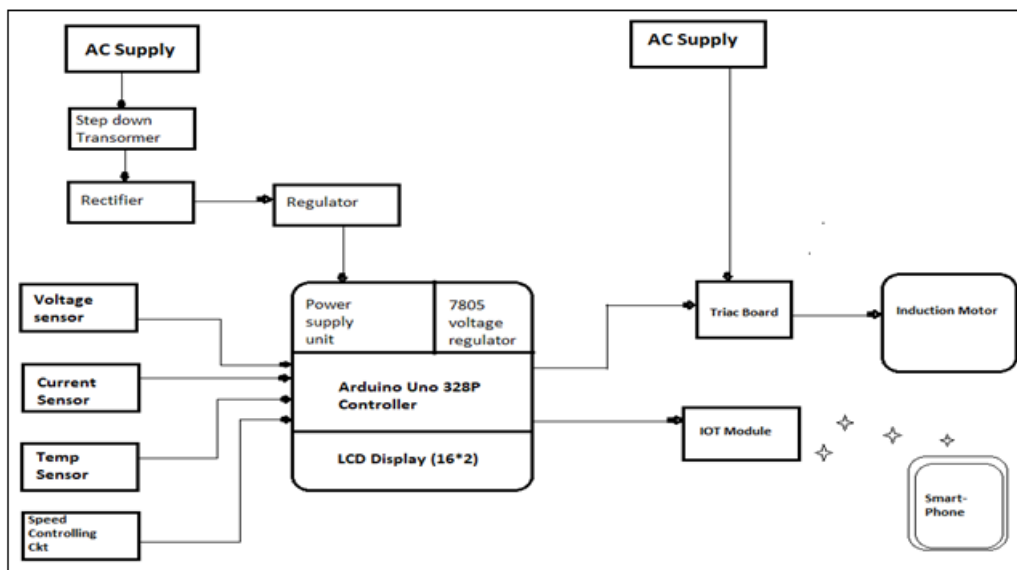

Figure 1: Proposed system

Parameter Sensing:

- Sensors measure vital parameters of the induction motor, including voltage, current, temperature, and speed.
- These sensors ensure continuous monitoring of motor health during operation.

Signal Processing:

- The sensor outputs are fed into the Arduino Uno microcontroller, which acts as the processing unit.
- The Arduino converts analog signals into digital data for further processing and decision-making.

Data Communication (IoT Integration):

- The processed data is transmitted through a Wi-Fi module (ESP8266) to a cloud server such as ThingSpeak.
- This enables real-time monitoring and storage of data accessible via web or mobile applications.

Display of Parameters:

- The monitored parameters are displayed sequentially on an LCD screen for local observation by operators.

Soft-Start Mechanism:

- Instead of direct-on-line starting, the system uses a soft-start technique to gradually increase the motor voltage.
- This reduces inrush current, mechanical stress, and improves energy efficiency.

Control Methods:

- Automatic Control: If any abnormal condition is detected (overload, overheating, unbalance), the motor supply is disconnected automatically to prevent damage.
- Manual Control: Users can remotely start or stop the motor using a mobile app connected to the IoT platform.

Preventive Maintenance:

- Continuous monitoring and automatic fault detection enable predictive maintenance, avoiding sudden breakdowns and extending motor lifespan.

Methods Used:

- IoT-Based Monitoring: Real-time monitoring of key parameters such as voltage, current, temperature, and speed using sensors and cloud integration.
- Soft-Start Mechanism: Gradual increase of voltage during startup reduces inrush current, torque stress, and mechanical wear.
- Automatic Fault Detection: Identifies abnormal conditions like overload, overheating, voltage imbalance, or single phasing and disconnects motor supply automatically.
- Remote Control: Operators can start or stop the motor manually through a mobile application or web platform.
- LCD Display: Sequential display of monitored parameters for easy local observation.
- Data Logging & Cloud Storage: Sensor data is stored on IoT cloud platforms (ThingSpeak) for analysis and preventive maintenance.
- High Reliability: Prevents sudden breakdowns and extends motor lifespan through continuous monitoring.
- Industrial & EV Applicability: Designed for use in heavy-duty industries and electric vehicle drive systems.

6. Conclusion

The review of literature on induction motor monitoring and control systems highlights the significant progress made in improving efficiency, reliability, and fault diagnosis. Traditional methods such as current, vibration, and thermal analysis provide a foundation for fault detection, but they are limited in real-time adaptability and accuracy under dynamic conditions. The integration of advanced technologies such as artificial intelligence and machine learning has enhanced the capability for early fault prediction and intelligent decision-making.

Moreover, the adoption of Internet of Things (IoT)-based systems has transformed conventional motor monitoring by enabling real-time data acquisition, remote accessibility, and predictive maintenance. Soft-start techniques have further contributed to reducing inrush current, minimizing mechanical stress, and improving motor lifespan and energy efficiency.

However, the literature reveals a lack of comprehensive systems that combine IoT, intelligent diagnostics, and soft-start control into a single framework. Therefore, there is a need for developing an integrated, cost-effective, and scalable solution. Such systems will play a vital role in advancing smart industrial automation and enhancing overall motor performance and reliability.

References

- [1] R. R. Kumar, M. Andriollo, and G. Cirrincione, "A comprehensive review of conventional and intelligence-based approaches for the fault diagnosis and condition monitoring of induction motors," *Energies*, vol. 15, no. 22, p. 8369, 2022.
- [2] R. Issa, G. Clerc, and M. H.-C., "Review of fault diagnosis methods for induction machines in railway traction applications," *Energies*, vol. 17, no. 2, p. 433, 2024.
- [3] D. Witezak and S. Szymoniak, "Review of monitoring and control systems based on the Internet of Things," *Applied Sciences*, vol. 12, no. 6, p. 3120, 2022.
- [4] M. Azab, "A review of recent trends in high-efficiency induction motor drives," *Energies*, vol. 17, no. 4, p. 1201, 2024.
- [5] S. Sobhi, M. H. Reshadi, N. Zarft, and A. Terheide, "Condition monitoring and fault detection in small induction motors: A review," *Information*, vol. 13, no. 7, p. 323, 2022.
- [6] B. H. Bahgat, E. A. Elhay, and M. M. Elkholy, "Advanced fault detection techniques of three-phase induction motor: A review," *Springer Journal of Electrical Engineering & Technology*, vol. 19, no. 3, pp. 1885–1902, 2024.
- [7] A. More and S. Kulkarni, "A review of IoT-enabled motor monitoring and control systems," *International Journal of Engineering Research (IJOER)*, vol. 10, no. 2, pp. 55–63, 2024.
- [8] A. Hussain, R. M. Larik, M. S. Saeed, and A. Y. Ali, "Enhancing three-phase induction motor performance with soft-ramp/soft-start control — Review & techniques," *International Journal of Information Science & Technology (IJIST)*, vol. 9, no. 1, pp. 101–112, 2024.
- [9] R. Kumar and R. S. Anand, "Health monitoring and fault analysis of induction motors: A review," *ResearchGate Preprints*, pp. 1–12, 2024.
- [10] E. Uhlmann, J. Polte, and C. Geisert, "IoT-based energy & production monitoring: Review and industrial use-cases," *Procedia CIRP / ScienceDirect*, vol. 128, pp. 250–258, 2024.
- [11] S. Nandi, H. A. Toliyat, and X. Li, "Condition monitoring and fault diagnosis of electrical motors—A review," *IEEE Transactions on Energy Conversion*, vol. 20, no. 4, pp. 719–729, Dec. 2005.
- [12] M. H. Benbouzid, "A review of induction motors signature analysis as a medium for faults detection," *IEEE Transactions on Industrial Electronics*, vol. 47, no. 5, pp. 984–993, Oct. 2000.
- [13] P. Zhang, Y. Du, T. G. Habetler, and B. Lu, "A survey of condition monitoring and protection methods for medium-voltage induction motors," *IEEE Transactions*

- on *Industry Applications*, vol. 47, no. 1, pp. 34–46, Jan.–Feb. 2011.
- [14] A. Kusiak and A. Verma, “A data-driven approach for monitoring blade pitch faults in wind turbines,” *IEEE Transactions on Sustainable Energy*, vol. 2, no. 1, pp. 87–96, Jan. 2011.
- [15] H. Henao, G.-A. Capolino, M. Fernandez-Cabanas, et al., “Trends in fault diagnosis for electrical machines: A review of diagnostic techniques,” *IEEE Industrial Electronics Magazine*, vol. 8, no. 2, pp. 31–42, Jun. 2014.
- [16] V. V. N. Kishore, R. S. Kiran, and B. K. Singh, “IoT-based health monitoring system for induction motor,” *International Journal of Engineering Research & Technology (IJERT)*, vol. 8, no. 6, pp. 102–106, 2019.
- [17] A. Glowacz, “Diagnostics of three-phase induction motors using thermal imaging and machine learning,” *Measurement*, vol. 132, pp. 620–628, Jan. 2019.
- [18] S. B. Lee, R. M. Tallam, and T. G. Habetler, “A robust, on-line turn-fault detection technique for induction machines based on monitoring the sequence component impedance matrix,” *IEEE Transactions on Power Electronics*, vol. 18, no. 3, pp. 865–872, May 2003.
- [19] J. Lee, B. Bagheri, and H.-A. Kao, “A cyber-physical systems architecture for Industry 4.0-based manufacturing systems,” *Manufacturing Letters*, vol. 3, pp. 18–23, Jan. 2015.
- [20] R. S. Mishra and P. K. Nayak, “Implementation of soft starter for induction motor using power electronics,” *International Journal of Power Electronics and Drive Systems (IJPEDS)*, vol. 10, no. 2, pp. 845–852, 2019.