

Speed Govern of SEDC Motor by Fuzzy Controller

Priyanka Sinha¹, Ritesh Diwan²

^{1,2}Raipur Institute of Technology, NH-6 Mandir Hasoud, Chhatauna, Raipur (Chhattisgarh), India-492001

Abstract: DC motor is a versatile motor and used in many industrial applications. By proper control action use of DC motor can be increase. In this paper propose fuzzy controller for speed control of separately excited DC motors. In industrial work PID controllers are used for the operation of DC motor. But it is seen that the PID controller are very much particular about the parameters means if any changes are occurred in parameters than theses methods are fail to control the motor. Also tuning of PID controller parameter is very difficult job. Whereas Fuzzy logic controllers allows the system to be defined by linguistic statements rather than complex differential equations. The results of fuzzy controller compared with Proportional plus Derivative plus Integral. Results shows that the Fuzzy logic controller gives better results compared to PID controllers. Feasibility of Fuzzy logic controller tested for different rule based decision system.

Keywords: Fuzzy logic controller (FLC), separately excited DC motor (SEDCM), proportion integral and derivative (PID)

1. Introduction

The purpose of a motor speed controller is to take a signal representing the demanded speed, and to drive a motor at that speed. The controller may or may not actually measure the speed of the motor. If it does, it is called a feedback speed controller or closed loop speed controller, if not it is called an open loop speed controller. Feedback speed control is better, but more complicated, and may not be required for a simple control design.

Many controllers were proposed for speed control of separately excited dc motor such as ; A constant-power field weakening controller based on load-adaptive multi-input multi-output linearization technique, single-phase uniform PWM ac-dc buck-boost converter, the superior performance of artificial intelligence (AI) based controllers urged power system and power electronic engineers to replace conventional speed control circuit with intelligent speed controllers. The major problems in applying the conventional control algorithms in a speed controller are the effects of non-linearity in a dc motor. The nonlinear characteristics of a dc motor such as saturation and friction could degrade the performance of conventional controllers.

Much of the interest in fuzzy control system and neural networks has arisen due to potential of handling uncertainty and imprecision in design of system. In general they improve machine IQ. The biggest advantage of fuzzy based system is a model free approach for design [1]. Most often an appropriate mathematical model of the dynamical system is not available and information access from human expert knowledge about plant operation. Direct current motors have been widely used in many industrial applications such as electric vehicles, steel rolling mills, electric cranes, and robotic manipulators due to precise, wide, simple, and continuous control characteristics [3]. For such application DC motor operate on various mode of Speed. For the operation on wide range of speed it requires a controller, to control the speed of motor to perform desired task.

The major problems in applying the conventional control algorithms in a speed controller are the effects of non-

linearity in a DC motor [4]. The nonlinear characteristics of a DC motor such as saturation and friction could degrade the performance of conventional controllers. Many advanced model-based control methods have been developed to reduce nonlinearity effects, such as proportional-integral-derivative (PID) control [8], classical control, State-space methods: state feedback [12], optimal control [7], robust control: H_2 or H_∞ methods, Nonlinear methods sliding mode control, Adaptive control [11], Self-tuning regulators, Nonlinear Adaptive control, Stochastic control (Minimum variance control, Linear quadratic Gaussian (LQG) Control), Discrete event systems. These control methods depends on the accurate system models and parameters. The main problem of using these controllers is the effect acquired as a result of disturbances and environmental conditions on the structure of the system, adding complexity to the controller's design.

The fuzzy logic approach do not required a fix model of DC motor and its results are also not affected by parameter variation [1][4]. Fuzzy logic offers a simpler, quicker and more reliable solution that is clear advantages over conventional techniques. Fuzzy control is more robust control method than usual conventional control to variation of system parameter.

2. Separately Excited Dc Motor System Description

2.1 Mathematical Model of Separately Excited DC Motor

A linear model of a simple DC motor consists of a mechanical equation and electrical equation as described in the equations [10] ;

Air gap flux given as

$$\phi = K_f I_f \quad (1)$$

The torque developed by the motor is given as

$$T_m = K_T I_a \phi \quad (2)$$

Back EMF of the DC motor is define as

$$e_b = K_b \frac{d\theta}{dt}$$

Or

$$e_b = K_b \omega_m \quad (3)$$

Taking Laplace transform we get

$$E_b(s) = K_b s\theta(s) \quad (4)$$

General equation of SEDCM is given as

$$V_a = R_a I_a + L_a \frac{di_a}{dt} + e_b \quad (5)$$

Taking Laplace transform on both sides we get

$$V_a(s) = R_a I_a(s) + s L_a I_a(s) + E_b(s) \quad (6)$$

Now by equation 2.3 & 2.4 we get

$$V_a(s) = R_a I_a(s) + s L_a I_a(s) + K_b s\theta(s) \quad (7)$$

$$I_a(s)(R_a + sL_a) = V_a(s) - K_b s\theta(s) \quad (8)$$

The load torque equation is

$$J \frac{d^2\theta}{dt^2} + f \frac{d\theta}{dt} = T_m = K_T I_a \quad (9)$$

Taking Laplace transform on both sides we get

$$(js^2 + fs)\theta(s) = T_m(s) = K_T I_a(s) \quad (10)$$

So armature current of the dc motor from eq.2.8 is given as

$$I_a(s) = \frac{T_m}{K_T} = \frac{js^2 + fs}{K_T} \theta(s) \quad (11)$$

Now by eq.10 & 11 we get

$$\frac{(js^2 + fs)(R_a + sL_a)}{K_T} \theta(s) = V_a(s) - K_b s\theta(s) \quad (12)$$

$$V_a(s) = \frac{(js^2 + fs)(R_a + sL_a)}{K_T} \theta(s) + K_b s\theta(s) \quad (13)$$

$$V_a(s) = \frac{[(js^2 + fs)(R_a + sL_a) + sK_b K_T]}{K_T} \theta(s) \quad (14)$$

$$\frac{\theta(s)}{V_a(s)} = \frac{K_T}{[(js^2 + fs)(R_a + sL_a) + sK_b K_T]} \quad (15)$$

Eq. 15, gives the transfer function of the separately excited dc motor.

Where, R_a = Armature resistance (Ω), L_a =Armature inductance (H), J_m =Motor of inertia ($kg.m^2/S^2$),

K_b =Motor constant and f =Damping friction coefficient.

The dynamic model of the system is formed as shown in fig.1 using these differential equations.

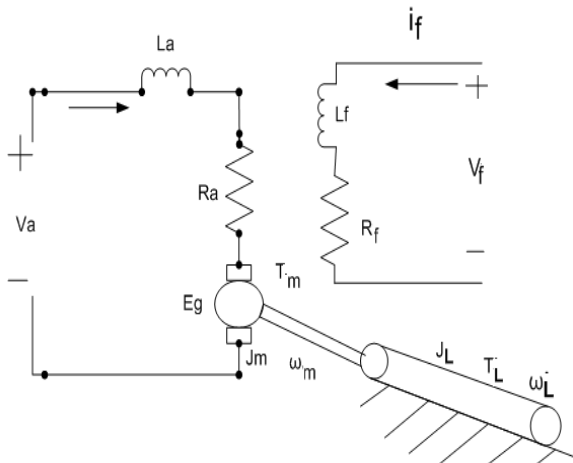

Figure 1: Dynamic model of separately excited DC

2.2 SEDC Motor Driver Circuit

Choppers are used to get variable dc voltage from a dc source of fixed voltage. The speed control of dc motor with power electronic systems is obtained generally by changing its terminal voltage.

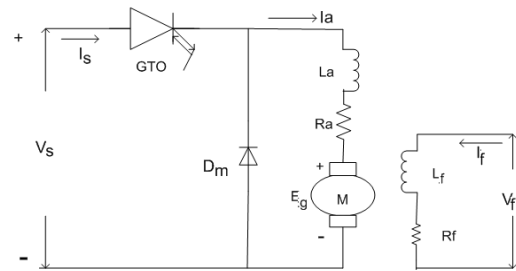

Figure 2: Chopper fed SEDC motor

Armature (DC) current is given as:

$$I_a = \frac{V_a - E_g}{R_a} \quad (16)$$

The average output voltage is calculated from:

$$V_{avg} = \frac{1}{T} \int_0^T V(t) dt = KV_m \quad (17)$$

The average output armature voltage can be calculated as

$$V_{avg} = \frac{T_{on}}{T_{on} + T_{off}} \cdot V_s \quad (18)$$

3. Descriptions and Design of Fuzzy Logic Controller

Fuzzy Sets Theory is first introduced in 1965 by Zadeh to express and process fuzzy knowledge [1]. The fuzzy logic foundation is based on the simulation of people's opinions and perceptions to control any system. One of the methods to simplify complex systems is to tolerate to imprecision, vagueness and uncertainty up to some extent. Fuzzy logic control is constructed on logical relationships.

There is a strong relationship between fuzzy logic and fuzzy set theory that is similar relationship between Boolean logic and classic set theory [6]. Fig. 3 shows a basic FLC structure.

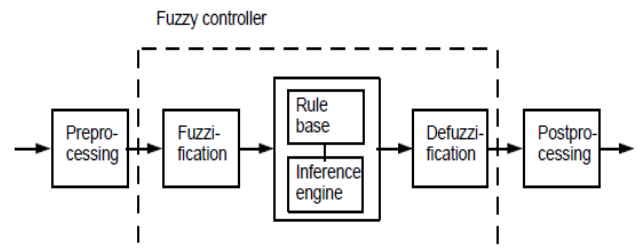

Figure 3: Structure of Fuzzy Controller.

Basically, FLC process is based on experiences and Linguistic definitions instead of system model. It is not required to know exact system model to design FLC. A defining Input and Output: The goal of designed FLC in this study is to minimize speed error. The bigger speed error the bigger controller input is expected. In addition, the change of error plays an important role to define controller input. Consequently FLC uses error and change of error for

linguistic variables which are generated from the control rules.

4. Matlab/Simpower Systems Model of DC Motor For PID Controller

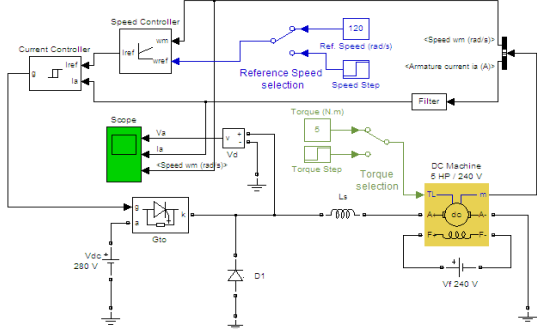

Figure 4: Matlab/Simulink model of SEDCM for PID controller

The simulation model of SEDC motor is shown in fig.4 used for the control of an armature control of DC motor using chopper circuit. It consists of a separately excited DC motor fed by a dc source through a chopper circuit. A single GTO thyristor with its control circuit and a free-wheeling diode form the chopper circuit. The motor drives a mechanical load characterized by inertia J, friction coefficient f, and load torque T_L . The control circuit consists of a speed control loop and a current control loop. A proportional-integral-derivative (PID) controlled speed control loop senses the actual speed of the motor and compares it with the reference speed to determine the reference armature current required by the motor.

4.1 Matlab/Simpower Systems Model of Dc Motor for Fuzzy Logic Controller

The Matlab/simulink model of SEDCM for fuzzy logic controller is shown in fig 6. This model have the same dc motor, chopper circuit and current controller as taken in fig 5. Only PID controller replaced by fuzzy logic controller.

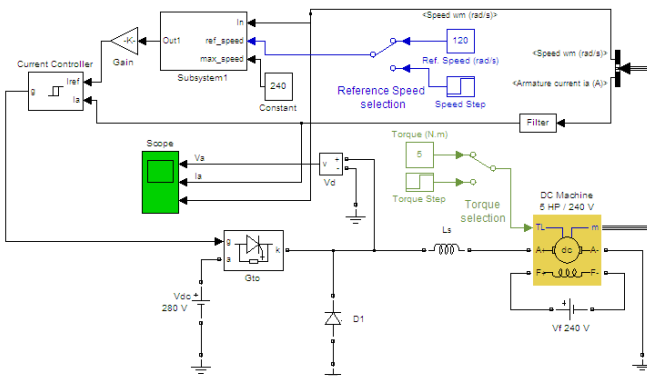

Figure 5: Matlab/Simulink model of SEDCM for Fuzzy logic controller

4.2 FUZZY Rules

Fuzzy rules for the 3 membership function is shown in fig.6

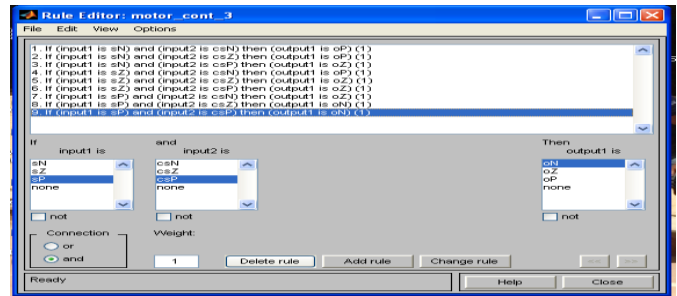

Figure 6: Fuzzy rules for 3 membership function

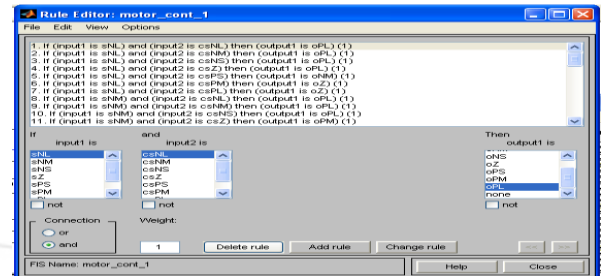

Figure 7: Fuzzy rules for seven membership function

5. Results and Analysis

First of all PID controller used for speed control of separately excited DC motor, from Matlab simulink model as reference [12] model and find out Simulink responses for various load torque. After that we replace PID controller by Fuzzy logic controller for same motor and parameters and find out simulink response for constant and variable load torque is shown below;

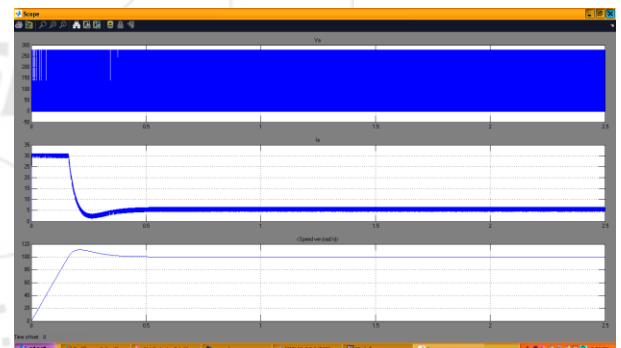

Figure 8: Simulink response of PID controller for torque $T_L = 5$ Nm and speed 100 rad/sec

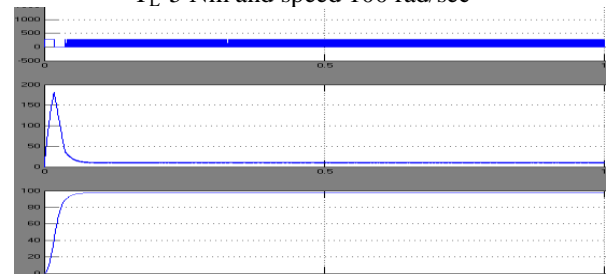

Figure 9: Simulink response of Fuzzy controller for torque $T_L = 5$ Nm and speed of 100 rad/sec

Simulink response of PID controller for constant torque (25Nm) and constant speed (120 rad/sec) is shown in fig8,its shows that rise time of response is about 0.2sec.its have

maximum overshoot at $t=0.24$ sec. after $t=0.421$ sec its give steady state response.

The response of the Fuzzy controller for the given Fuzzy rules is shown in fig.9, its shows that rise time of response is about 0.23 sec. and it is free from maximum overshoot. after $t=0.25$ sec its give steady state response.

For the validity of the results we find out the simulink response of the PID and fuzzy logic controller for different load torque and speeds as shown in fig (10 &11)

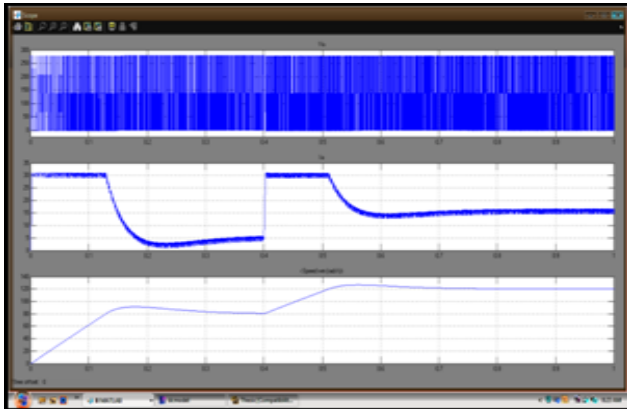

Figure 10: Simulink response of PID controller for $T_L=5$ to 17 Nm and speed (80 & 120 rad/sec)

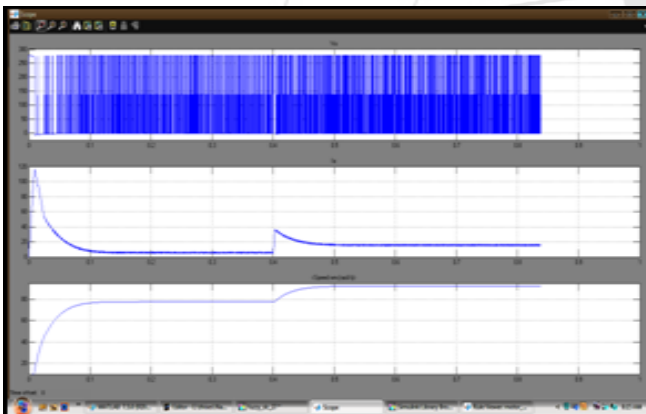

Figure 11: Simulink response of FLC for 7- membership function ($T_L=5$ to 17 Nm) and speed (80 to 120 rad/sec)

Tables

Table 1: Comparative response of the controllers

Controller	Speed (rad/Sec)	Overshot	Rise time (Second)	Settling time (Second)	Steady state time (Second)
PID	120	10 (rad/Sec)	0.2	0.3	0.5
Fuzzy logic (3 membership function)	120	0	0.04	0.05	0.07
Fuzzy logic (5 membership function)	120	0	0.03	0.04	0.06
Fuzzy logic (7 membership function)	120	0	0.02	0.03	0.05

6. Conclusions

It is seen that the fuzzy controller can be adjusting the fuzzy rules according to the change of error and change in error and it is concluded that the fuzzy controller as compared With the conventional PID controller, it provides improvement performance in both transient and the steady states response, fuzzy controller has no overshoot and gives steady state operation.

References

- [1] L. A. Zadeh, "Fuzzy Sets," in Information and Control, vol.8.New York: academic press, pp. 338-353, 1965
- [2] E. H. Mamdani, "Application of fuzzy algorithms for the control of a dynamic Plant", IEEE conference, 121 pp. 1585-1588,1974.
- [3] Romeo U. Parrazales , "a fuzzy logic controller applied to a DC motor", IEEE conference, pp.653-6566, 2008.
- [4] M.M.R. Ahmedl, "fuzzy logic speed control of DC motors fed by single-ended primary inductance converters (sepic)", IEEE conference , pp.343-347, 2008
- [5] Yodyium Tipsuwan, "A Neuro-Fuzzy network-based controller for dc motor speed Control", IEEE conference, pp.2433-2438, 2005.
- [6] G. uma j. latha, "A fuzzy based speed controller for soft switched dc to dc converter fed dc servomotor for aero space applications", IEEE conference, pp.730-734, 2000.
- [7] Maher M.F. Algreer, "Design fuzzy self tuning of PID controller for chopper-fed dc motor drive", Al-Rafidain engineering Vol.16, PP.54-66, 2008.
- [8] Zuhtu Hakan, "Non-singleton fuzzy logic control of a dc motor", journal of applied science, ISSN1812-5654, vol.5, pp. 887-891, 2005.
- [9] Authors Yodyium Tipsuwan, "Fuzzy logic microcontroller implementation for dc motor speed control", IEEE conference, pp.840-846, 1999.
- [10] Moleykutty George, "Speed control of separately excited dc motor", American Journal of applied sciences 5 (3) Science Publications: ISSN 1546- 9239, pp.227-233, 2008.
- [11] Mohamed M. M. Negm, "experimental investigation of speed control of dc motor based on optimal PID controller", IEEE conference, pp-35-41, 2003.
- [12] H.Lehuy, "MATLAB Help" ver.7.5, Math works, Inc., 2007.