

# Performance Analysis of Hybrid WDM/TDM PON Using Various Coding Techniques

Jisha V S<sup>1</sup>, Sunaina N<sup>2</sup>

<sup>1</sup>P G Scholar, Optoelectronics and Communication Systems, Department of ECE, T K M Institute of Technology  
Kollam, India

<sup>2</sup>Assistant Professor, Department of ECE, T K M Institute of Technology, Kollam, India

**Abstract:** *Time Division Multiplexing (TDM) and Wavelength Division Multiplexing (WDM) are the most popular multiplexing methods. Each of these multiplexing methods has its own pros and cons. Time division multiplex is able to serve only a small number of participants with low speed, however, for reasonable prices. On the other hand, wavelength division multiplex can serve a high number of participants but its price is much higher. In light of these different properties, there is an effort to create a Hybrid WDM/TDM network that would have positive characteristics of both of these multiplexes and at the same time would meet the characteristics of the Passive Optical Network (PON). Hybrid WDM/TDM PON have been simulated using NRZ, RZ and Manchester coding for different bit rates, input power and fiber lengths. The entire topology design was realized using the OptiSystem version 12 software.*

**Keywords:** OLT, ONU, TDM, WDM, HAPON

## 1. Introduction

Emerging bandwidth hungry applications like video on demand, High Definition TV (HDTV), video conferencing, high quality audio transmission and data traffic, high speed internet, online gaming etc. have tremendously increased the bandwidth demand which cannot be met by the current access network infrastructure. An Access Network encompasses the elements between a local office and the subscriber. The explosive growth in demand for higher bandwidth has triggered the introduction of Fiber-to-the-Home (FTTH) based broadband access networks. Among various FTTH implementations, Passive Optical Networks (PON), which can provide very high bandwidth to the customers, appear to be an attractive solution to the access network. PON consist of OLTs (Optical Line Terminals) situated at the CO (Central Office) and ONUs (Optical Network Units) situated at the customer premises.

At present, most of the PON deployments utilize Time Division Multiplexing (TDM) technique, in which dedicated time slots are assigned to each ONUs connected to the PON. Time Division Multiplexed Passive Optical Network (TDM PON) was implemented using P2MP (Point-to-Multipoint) network architecture. The bandwidth provisioned by an optical channel and the hardware in the CO are thus shared among all the users, which is highly desirable to reduce the cost of the access network. But the TDM PON cannot cope with the requirements of future network evolution with respect to aggregated bandwidth and the allowable power budget. Moreover it is able to serve only a small number of users with low speed and for short distances [7].

These problems can be mitigated with Wavelength Division Multiplexed Passive Optical Networks (WDM PONs), in which ONUs are assigned individual wavelengths such that the bandwidth of fiber is utilized more effectively to further increase the transmission speed. Incorporating WDM in a PON allows one to support higher bandwidth since each

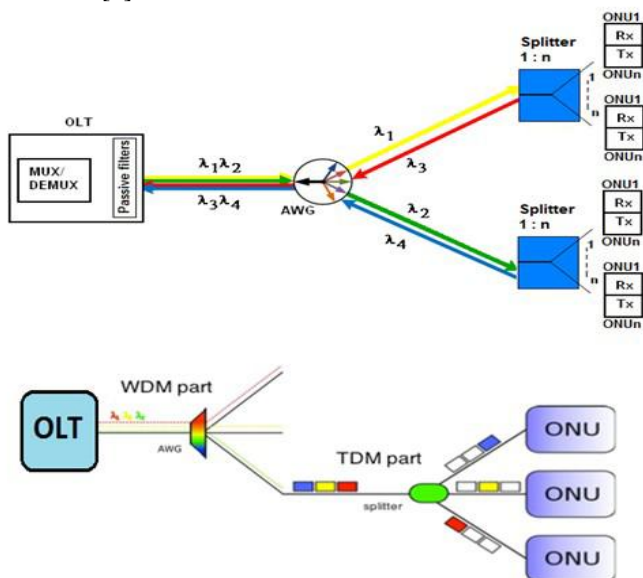
wavelength is dedicated to a single subscriber. The WDM PON offers other advantages such as ease of management and upgradability, strong network security, high flexibility with data and protocol transparency [3] [6].

In light of these different properties, there is an effort to create a hybrid network that would have positive characteristics of both of these multiplexes and at the same time would meet the characteristics of the passive optical network. The hybrid PON concept could fulfil the multi-application scenario requirements and can provide a solution for the drawbacks faced by TDM PON and WDM PON. To provide the advantages of WDM PON and to integrate WDM PONs with the existing TDM based PONs, Hybrid TDM/WDM architectures have been proposed. Hybrid architectures seems to be advantageous as it can combine the advantages of individual networks. Infinite bandwidth capacity of each strand of fiber can be well utilized. Depending on the network utilization bandwidth can be assigned on demand, business and home users can also be made to coexist in the same network while bringing down the cost. Hybrid PONs architectures provide cost-effective, long reach and large bandwidth to the customer. Therefore, research into different hybrid PON architectures, used in conjunction with different modulation techniques and other performance enhancing solutions should also be investigated to further realize the best performance out of the hybrid PON [2].

## 2. Overview of Hybrid WDM/TDM PON

With the standardization of TDM PONs, a cost-effective access technology based on optics has been developed. However, further development needs to be carried out in order to fully exploit the benefits of optical fiber technology. WDM PONs are an option, where capacity per user can be very high, but their cost does not make them attractive for practical implementation nowadays. Several recent proposals

have demonstrated the feasibility of combining WDM and TDM to optimize network performance and resource utilization. A PON combining WDM and TDM technologies, referred to as Hybrid WDM/TDM PON or HPON, is one of the most promising candidates for NGOA networks due to its ability to serve a large number of subscribers and offer high capacity per user. This solution is mainly based on the exploitation of the advantages provided by both TDM-PONs and WDM-PON. In the TDM/WDM-PON, the high split ratio provided by the TDM-PONs and the large number of wavelengths offered by the WDM-PONs are joined into one hybrid. Figure 1 depicts the generic Hybrid WDM/TDM PON scheme. Hybrid WDM/TDM PON is becoming a promising solution for next-generation broadband optical access. Instead of using only one wavelength to provision bandwidth in upstream and downstream as TDM PON does, Hybrid WDM/TDM PON increases the number of working wavelengths in each stream to exploit the high bandwidth of optical fibers. On the other hand, Hybrid WDM/TDM PON bridges the gap between TDM PON and pure WDM PON and can be deployed by smoothly migrating from the currently deployed TDM PON. Hybrid PONs architectures provide cost-effective, long reach and large bandwidth to the customer [1].



**Figure 1:** Hybrid WDM/TDM PON

### 3. Coding Techniques

In telecommunication, a line code (also called digital baseband modulation or digital baseband transmission method) is a code chosen for use within a communications system for baseband transmission purposes. Line coding is often used for digital data transport. Line coding defines the arrangement of symbols in a particular pattern for transmission that represent binary data. The line coding approach converts digital data to digital signal.

#### 3.1 NRZ Coding

NRZ (Non-Return-to-Zero) coding is a line code in which binary value 1 is represented by positive voltage and 0 is represented by negative voltage. It requires only half the bandwidth than other coding. This is for Bipolar NRZ

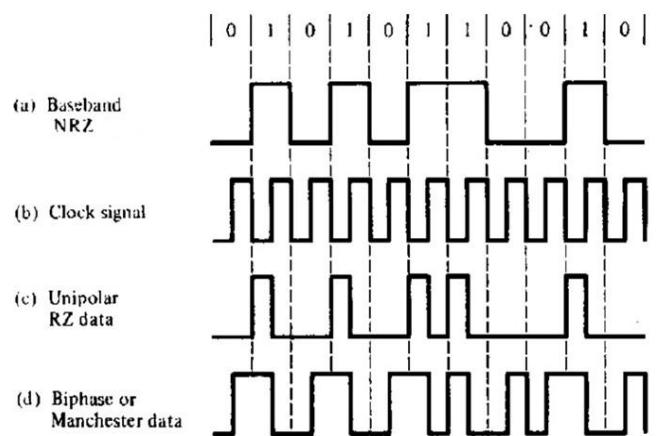
coding. There is also another type called unipolar NRZ coding, in which 1 is represented by positive voltage and 0 is represented by DC line. NRZ codes are easy and it makes efficient use of bandwidth.

#### 3.2 RZ Coding

In RZ (Return-to-Zero) encoding, a binary 1 is represented by first half of the bit duration, during the second half the level returns to zero. There is a “zero” condition typically halfway between the significant condition representing a 1 bit and the other significant condition representing a 0 bit. Absence of a pulse represents a binary 0, during the entire bit duration. Twice the bandwidth is required for RZ coding, because for data transmission it takes only half a bit duration. The signal is self-clocking. This means that a separate clock does not need to be sent alongside the signal, but suffers from using twice the bandwidth to achieve the same data-rate as compared to non-return-to-zero format.

#### 3.3 Manchester Coding

Manchester code is another type of line coding technique used for data transmission, also called as Phase Encoding. In this type of encoding, each bit has minimum one transition and occupies the same time. Since the DC component carries no data, it is not present in this coding. It ensures frequent line voltages, directly proportional to the clock rate. Figure 2 shows various coding techniques [5].



**Figure 2:** Different Coding Techniques

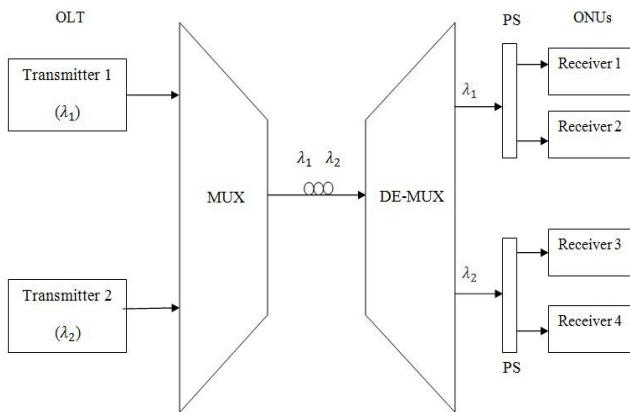
### 4. Simulation Software

The software used is Optisystem Version 12. The OptiSystem software is developed by Optiwave to perform complex optical communication simulation. It provides an easy user interface which is common to many other electrical engineering tools. The OptiSystem software is suitable to be used to model and simulate fiber optic system. As a system level simulator based on the realistic modeling of fiber-optic communication systems, OptiSystem possesses a powerful simulation environment and a truly hierarchical definition of components and systems. Its capabilities can be easily expanded with the addition of user components and seamless interfaces to a range of widely used tools. Designing, testing and optimization of virtually any type of optical links in the

physical layers based on a large collection of realistic models for components and sub-systems is possible by this software.

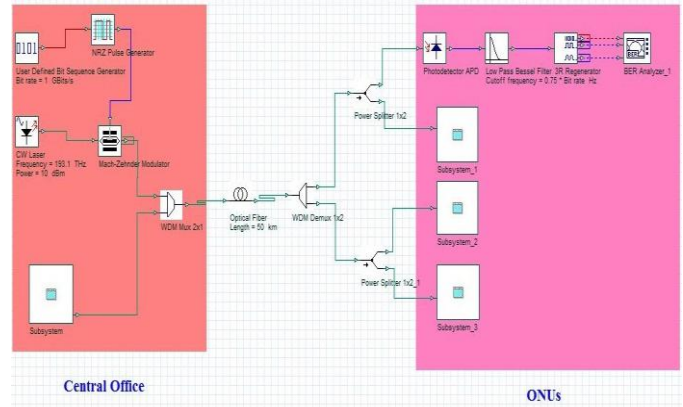
## 5. Design and Simulations

The combination of WDM and TDM PON results in a hybrid network that is able to increase the number of users with adequate bandwidth to every user. Figure 3 shows the overall system configuration of a Hybrid PON. The OLT consists of a pair of data sources, pulse generators, light sources and modulators. The light sources emit at different frequencies. The signals are combined together by a WDM MUX for transmission over the fiber. At the remote node the signals are separated out using a WDM DE-MUX. Then power splitters are employed to broadcast the signal to the ONUs. Each ONU consists of a photodetector which converts the optical signal to electrical signal, a low pass electrical filter which filters the signal to reduce its noise and a BER analyzer.

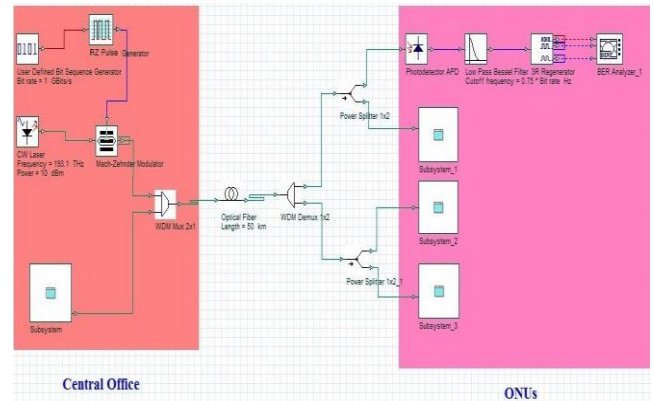


**Figure 3:** Block diagram of Hybrid WDM/TDM PON

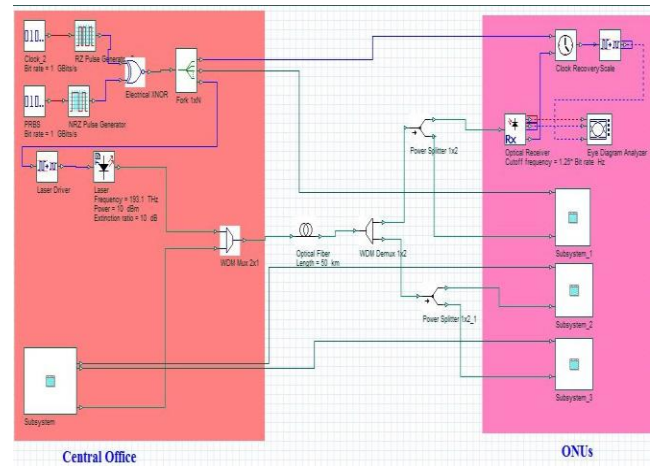
The CO consists of two OLTs. The light sources emit at different frequencies. The frequencies at OLT 1 and OLT 2 are 193.1 and 193.2 THz respectively. The signals are combined together by a WDM MUX for transmission over the fiber. At the remote node the signals are separated out using a WDM DE-MUX. Then power splitters are employed to broadcast the signal to the ONUs. Here two power splitters are used with a splitting ratio of 1x2. Four ONUs are present. ONU1 and ONU 2 operate at 193.1 THz. ONU 3 and ONU 4 operates at 193.2 THz. The data rate is 1 Gbps and the result is obtained for different fiber lengths. Each ONU consists of an APD which converts the optical signal to electrical signal, a low pass Bessel filter operating at a cutoff frequency of 0.75 times the bitrate and a BER analyzer. The parameters that are analyzed are Q-factor and BER (Bit Error Rate). The simulation setup for NRZ, RZ and Manchester coding is shown in Figure 4, 5 and 6 respectively.



**Figure 4:** Simulation using NRZ coding



**Figure 5:** Simulation using RZ coding



**Figure 6:** Simulation using Manchester coding

## 6. Results and Discussions

### 6.1 Eye diagrams for NRZ, RZ and Manchester coding

Figure 7 shows the eye diagram for NRZ, RZ and Manchester coding at input power 10 dBm, bit rate 1Gbps and fiber length 50 Km and Figure 8 shows the eye diagram for 150 Km. The results show that a better performance is achieved at 50 Km because the eye is wide open at 50 Km rather than at 150 Km.



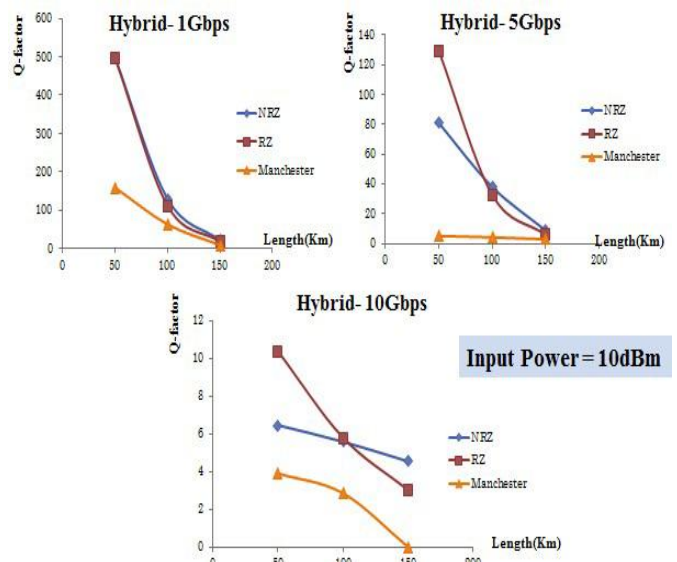
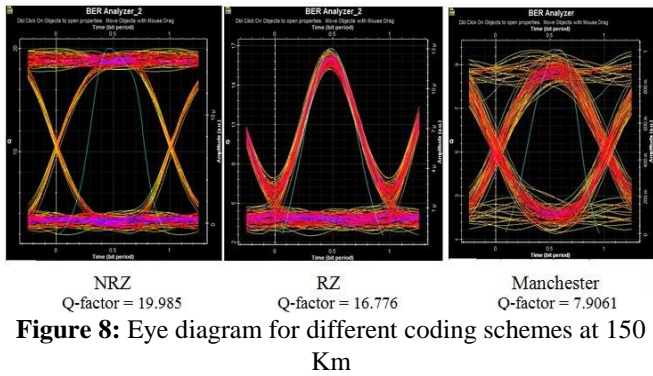
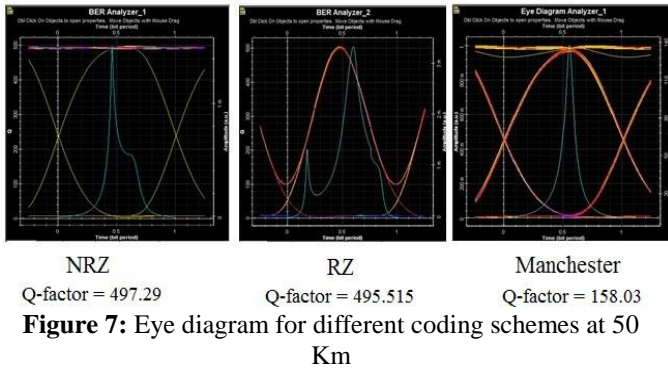


Figure 10: Comparison for different Bit Rates

### 6.2 Q-factor vs Fiber Length for Different Input Power

The graphical representation shown in Figure 9 shows the variation of Q-factor with fiber length for different input powers. It reveals that the Q-factor increases with an increase in input power. The input powers used are 0.2, 5 and 10 dBm for different lengths 50, 100 and 150 Km.

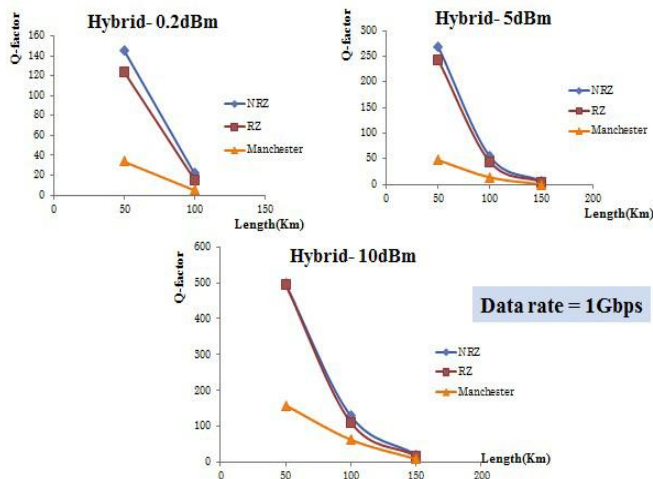


Figure 9: Comparison for different Power levels

### 6.3 Q-factor vs fiber length for different bit rates

The variation of Q Factor as a function of fiber length for different bit rates is shown in Figure 10. It is found that as the bit rate increases the Q-factor decreases. NRZ is better for 1 Gbps while RZ is better for 5 and 10 Gbps.

## 7. Conclusion

With the emergence of new bandwidth hungry applications there is a bottleneck in the current access network. TDM and WDM PON technologies provide a solution to this bottleneck but have its own pros and cons. So there is an effort to create a Hybrid WDM/TDM PON that would have positive characteristics of both the multiplexing techniques. It can provide a solution for the drawbacks faced by TDM and WDM PON. It is used in bandwidth intensive, cost effective next generation optical access network. A comparative study of Hybrid WDM/TDM PON using different coding techniques, bit rates, input power and fiber length are done. It is simulated using OptiSystem software and the results were analyzed. Hybrid WDM/TDM PON offers a great potential and a very attractive solution for the future next generation access network.

## References

- [1] Kumbirayi Nyachionjeka1, Wellington Makondo, "Effects of Modulation Techniques (Manchester Code, NRZ or RZ) on the Operation of Hybrid WDM/TDM Passive Optical Networks", International Scholarly Research Notices, July 2014.
- [2] Mozghan Mahloo, Jiajia Chen, and Lena Wosinska, Abhishek Dixit, Bart Lannoo, and Didier Colle, "Toward Reliable Hybrid WDM/TDM Passive Optical Networks", IEEE Communications Magazine, February 2014.
- [3] N Subhashini, A Brintha Theresse, "Performance Evaluation of Next Generation Access Network Architectures", International Journal of Engineering Research and Applications, Vol 3, Issue 6, Nov-Dec 2013.
- [4] Raman, Simranjith Singh, "Investigation of Hybrid WDM/TDM PON in the Presence of Optical Amplifiers to enhance the System Capacity", International Journal of Advanced Research in Computer Science and Software Engineering, Volume 3, Issue 9, Sept 2013.

- [5] Oshin Kharola, Nisha Sharma, "Line Coding : An Overview", International Journal Of Advance Research In Science And Engineering, Volume 2, Issue 9, Sept 2013.
- [6] S. Rajalakshmi, Ankit Srivastava, Ashish Pandey, "Performance Analysis of Receivers in WDM for Extended Reach Passive Optical Networks", IJCSI International Journal of Computer Science Issues, Vol. 9, Issue 2, No 3, March 2012.
- [7] A S. Rajalakshmi, Ankit Srivastava, Ashish Pandey, "Analysis of TDM and WDM PON using Different Coding Schemes for Extended Reach", International Journal of Computer Science and Network Security, Vol 11, No. 7, July 2011.