

Data Services of Li- Fi in Hospital Management

Ankit Navalakha¹, Neelu Maheshwari²

Department of Computer Science, Mewar University, Gangrar, Chittorgarh (Raj.), India

Abstract: For Online help from expertise in medical therapy doctors can exchange videos/ live information about patient for their best surgery results. But in this online help Radio Frequency spectrum produced by Wi-Fi connection is harmful for patient's body so instead we can use Li-Fi a technology that uses light emitting diodes to transmit data wirelessly. This paper will focus on Li-Fi (Light Fidelity) technology over Wi-Fi (Wireless Fidelity) technology and challenges for transmitting personal information about patient during their surgery/Medical Therapy session.

Keywords: Li-Fi, Wi-Fi, Radio Frequency Spectrum

1. Introduction

Present scenario the bandwidth capacity which is available is finite & is not capable enough to sustain with the constantly increasing demand of wireless data. Wireless Fidelity has been in use from almost years to provide the internet services to all the required places right from home to humungous organizations. With High definition video & audios available for the viewers, it is becoming intricate to transfer them to the user flawlessly [1].

As we know about Wi- Fi, when number of users get increased in wireless network speed decreases proportionally. Wi-Fi gives us speed up to 150MBPS as per IEEE 802.11n, it is still insufficient to accommodate number of desired users.

One more fact about Wi- Fi is that it produces Radio Frequency Spectrum which is very harmful for everybody. Through this radio frequency spectrum human body get affect by several diseases like cancer, neurological disease, reproductive disorders, immune dysfunction, and electromagnetic hypersensitivity etc.

2. Objective

By the mid 1990's, it became clear that patients were adversely affected by electromagnetic fields and becoming more electrically sensitive. With the advancement of wireless devices, radio frequency (RF) spectrum increases regularly and accordingly it affects human body by diseases such as cancer, neurological disease, reproductive disorders, immune dysfunction, and electromagnetic hypersensitivity etc.

So here we use the immerging technology that is Li- Fi which is based on light produced by LEDs instead of Radio frequency spectrum produced by Wi- Fi. By applying this technology we can create a harmless environment in specific areas like- Hospitals.

This technology doesn't deal with radio waves and produce better results than Wi- Fi, so widely useful in the area of medical science. As treatment of patient does not effected by LEDs that is if a doctor want to consult from other expertise for any treatment of patient then they can make a video conference in hospitals/OTs, so it will not affect patient's body and they can get best results. Similarly on large scale it

can also easily applied in the places where Bluetooth, WIFI and other source of communication can't reach.

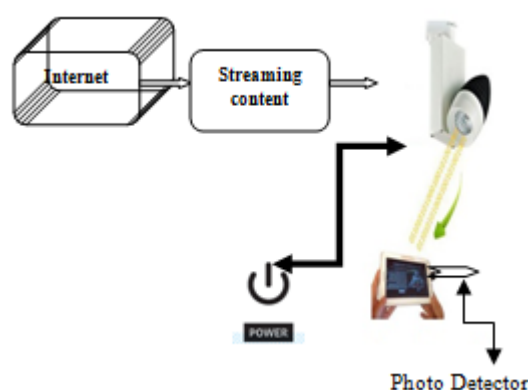

Figure 1: Structure of Li- Fi

3. LI- FI Basics

Li-Fi is a wireless communication system which is used to produce visible light communication for high speed wireless communication. It acquired this name due to similarity to Wi-Fi, or an alternative to Wi-Fi that utilizes light rays instead of radio waves, this light produced by light-emitting diodes, or LEDs. So it's an internet of light, or maybe LED net.

This was developed by German physicist, Harald Hass. It is a technology that may be as fast as 500MBPS (30GB per minute), an alternative, cost effective, more robust and useful than Wi-Fi.

Li- Fi was demonstrated in 2012 at consumer electronics show in las Vegas using a pair of Casio Smartphone's to exchange data using light of varying intensity given off from their screens, detectable at a distance of up to 10 meters [2].

Li-Fi is transmission of data through illumination by using fiber optics and sending data through a LED that varies in intensity faster than the human eye can follow. Microchips inside LED will do the processing of data. The light intensity can be manipulated to send data by tiny changes in amplitude. The technology transfers thousands of streams of data simultaneously in higher speed with the help of special modulation technique.

4. Communication in Hospitals

The care of patients now almost inevitably seems to involve many different individuals, all needing to share patient information and discuss their management. As a consequence there is increasing interest in, and use of, information and communication technologies to support health services. Yet, while there is significant discussion of, and investment in, information technologies, communication systems receive much attention and the clinical adoption of even simpler services like voice-mail or electronic mail is now commonplace in many health services.

As well as communication requirements increases in hospitals, use of Wi-Fi devices increases automatically and as we have discussed before Wi-Fi communication devices produces Radio frequency spectrum which is harmful for everybody. So now we want to replace this wi-fi communication via Li-Fi [3][4].

This Li-Fi based hospital system management secure patients body from attack of many types of disease as resistance power of patient is very low.

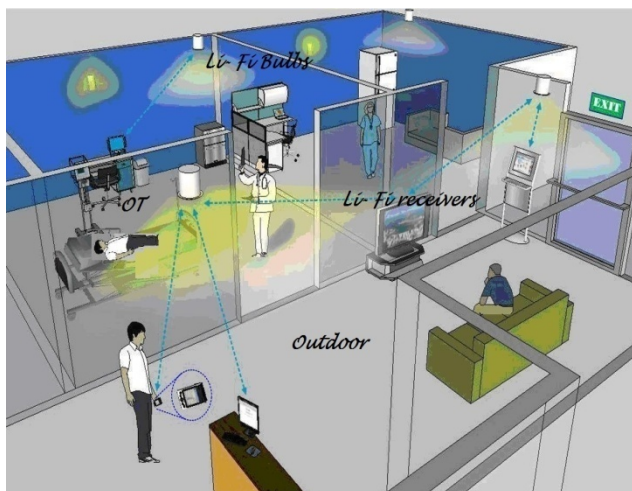

Figure 2: Communication in Hospital

5. LI-FI Architecture

Li-Fi is implemented using white LED light bulbs at the downlink transmitter. These devices are normally used for illumination only by applying a constant current. However, by fast and subtle variations of the current, the optical output can be made to vary at extremely high speeds. This very property of optical current is used in Li-Fi setup. The operational procedure is very simple-, if the LED is on, you transmit a digital 1, if it's off you transmit a 0. The LEDs can be switched on and off very quickly, which gives nice opportunities for transmitting data. Hence all that is required is some LEDs and a controller that code data into those LEDs. All one has to do is to vary the rate at which the LED's flicker depending upon the data we want to encode. Further enhancements can be made in this method, like using an array of LEDs for parallel data transmission, or using mixtures of red, green and blue LEDs to alter the light's frequency with each frequency encoding a different data channel. Such advancements promise a theoretical

speed of 10Gbps – meaning one can download a full high-definition film in just 30 seconds [5].

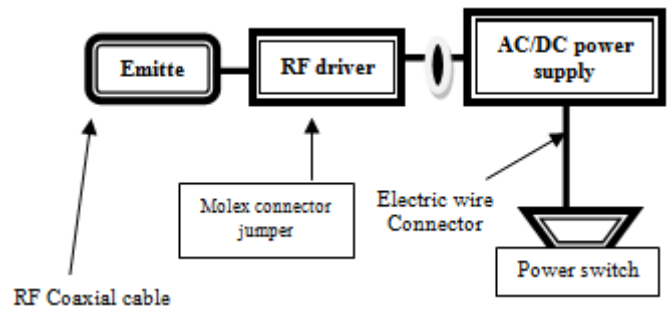

Figure 3: Li-Fi Architecture

6. Benefits

In this way, it will be most helpful transferring medium for us. It includes other benefits like:

- A free band that does not need license.
- High installation cost but very low maintenance cost.
- Cheaper than Wi-Fi.
- Lower electricity costs
- Longevity of LED bulb: saves money.
- Light doesn't penetrate through walls: secured access.
- No more monthly broadband bills.
- Speed up to 1 GB per second i.e. Less time & energy consumption
- A very wide spectrum over visible wave length range.
- Extremely high color fidelity.
- Instant start time.
- Easy transmission.
- And best one is harmless for human beings.

7. Limitations

Li-Fi is certainly not useless, but it has certain inherent limits for the technology. Li-Fi may not be able to replace conventional radios altogether, but it can be enhanced in development of wireless communication so we can partially remove disease by removing a wireless(Radio Frequency) signal from hospitals where human body is more sensitive by environment [6].

Some other limitations are:

- It only works if there is direct line of sight (LOS) between the transmitter and receiver.
- Any type of obstacle can easily stop data transmission.
- The use of very high frequencies (400-800THz) limits it to very short distances and point to point communications only.

8. Conclusion

This technology doesn't deal with radio waves, so it can easily be used in Hospitals where Li-Fi is the upcoming and on growing technology acting as component for various other developing and already invented technologies. Since light is the major source for transmission in this technology it is very advantageous and implementable in various fields that can't be done with the Wi-Fi and other technologies. Hence the future applications of the Li-Fi can be predicted and extended to different plat-

forms like education fields, industrial areas and many other fields.

References

- [1] www.lificonsortium.org [Viewed 11 Jan 2014, verified 12 Jan 2014]
- [2] [http://beyondweblogs.com/what-is-li-fi-is-this-replacing- Wi-Fi/](http://beyondweblogs.com/what-is-li-fi-is-this-replacing-Wi-Fi/) [Viewed 13 Jan 2014, verified 13 Jan 2014]
- [3] [Technopits.blogspot.com/technology.cgap.org](http://Technopits.blogspot.com/technology/cgap.org) [Viewed 19 Jan 2014, verified 21 Jan 2014]
- [4] Li-Fi – Internet at the Speed of Light, by Ian Lim, the gangster, [Viewed 28 Jan 2014, verified 29 Jan 2014]
- [5] "Visible-light communication: Tripping the light fantastic: A fast and cheap optical version of Wi-Fi is coming". The Economist. [Viewed 2 Feb 2014, verified 2 Feb 2014]
- [6] Haas, Harald (July 2011). "Wireless data from every light bulb". TED Global. Edinburgh, Scotland. [Viewed 6 Feb 2014, verified 8 Feb 2014].

Author Profile



Ankit Navalakha received the B.E. in Computer Science in 2012 and Pursuing M.Tech. in Computer Science Engineering from Mewar University, Gangrar, Chittorgarh, Rajasthan (INDIA). Since 2012 working as Associate Lecturer in MEWAR UNIVERSITY, Chittorgarh, Rajasthan (India).



Neelu Maheshwari received the B.E. in Information Technology in 2009 from RU Jaipur, Rajasthan and Pursuing M.Tech. in Computer Science Engineering from RTU, Kota, Rajasthan (INDIA). Since 2013 working as Associate Lecturer in MEWAR UNIVERSITY, Chittorgarh, Rajasthan (India).